

NEBRASKA

Good Life. Great Journey.

DEPARTMENT OF TRANSPORTATION



NDOT Concrete Repair Manual

- Disclaimer: This is only a manual of practice, it is not a substitute for good judgment or a replacement for language in the contract or details shown in the plans

Construction Division: Andy Dearmont
Materials & Research Division: Chris Dowding

Exposed Concrete

- Curb repairs 4 -12
- Inlet covers 13
- Full Depth Repairs 14-33
- Joint Repairs 34-36
- Partial Depth Repairs 37-47
- Medians 48
- Cross- stitching 49-59
- Cracks no action needed 60-61
- Practices to avoid 62-64
- Spalls 65
- Sidewalks 66

Asphalt over Concrete

- Typical distresses 67
- Description of work 68
- Previously Crack and Seated 69
- Photos of common distress 70-72
- Removals and Preparation 73-77
- Placement, Curing, Blankets 78-79

Miscellaneous

- Base Replacement 80-84
- Bond Breaker 85-86
- Sealing Repairs, Joints and Cracks 87-89
- Sounding Pavement 90
- Numbers to Remember 91
- Epoxy 92
- Historic Steel Placement 93

M & R Field Surveys

- Examples 94-116

Exposed Concrete

- Curb Repairs
- Inlet Covers
- Full Depth Repairs
- Joint Repairs
- Partial Depth Repairs
- Medians
- Cross- stitching
- Sidewalk Repair
- Foundation Course Replacement

Curb Repair (Exposed Concrete)

Saw Cut Existing Curb and Replace with Integral Curb

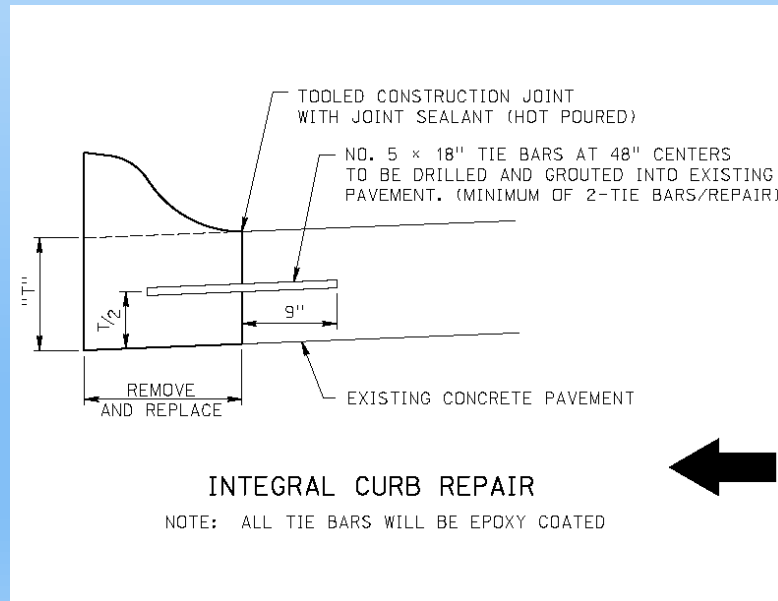

Curb Repair (Exposed Concrete)

Work to be done:

1. Saw cut and remove curb.
2. Restore base and compact in place.
3. Drill holes into existing pavement and curb.
4. Install epoxy coated 18"x #5 bars using epoxy adhesive.
5. Clean vertical faces of existing concrete.
6. Place portland cement concrete, vibrate, finish, and apply curing compound.
7. Hand tool plastic concrete to match existing joint pattern, before applying curing compound

Photographs of Curb Repair

Repairs are needed



Often during the Pre-Letting survey, curbs are covered and a fair assessment is not possible. In this situation an estimated LF of curb are provided but no locations.



Photographs of Curb Repair

Not Repaired – too small

Repairs are needed



Photographs of Curb Repair

Not Repaired – too small

Repairs are needed



Photographs of Curb Repair

Not Repaired – too small



ASR - If curb material is unsound, it makes more sense to not stop and start replacement but rather replace long stretches of unsound material.



Photographs of Curb Repair

Combination Curb and Gutter Repair:

1. This item is only used when the roadway is full depth asphaltic concrete.
2. Repairs are tied to the curb on either side and not to the full depth asphalt.

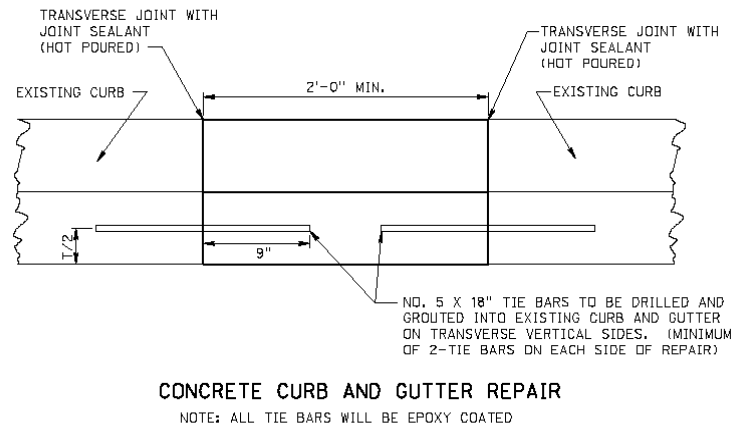

Combination Curb and Gutter

Photographs of Curb Repair

Repair or it will pop loose soon



Not Repaired – too small

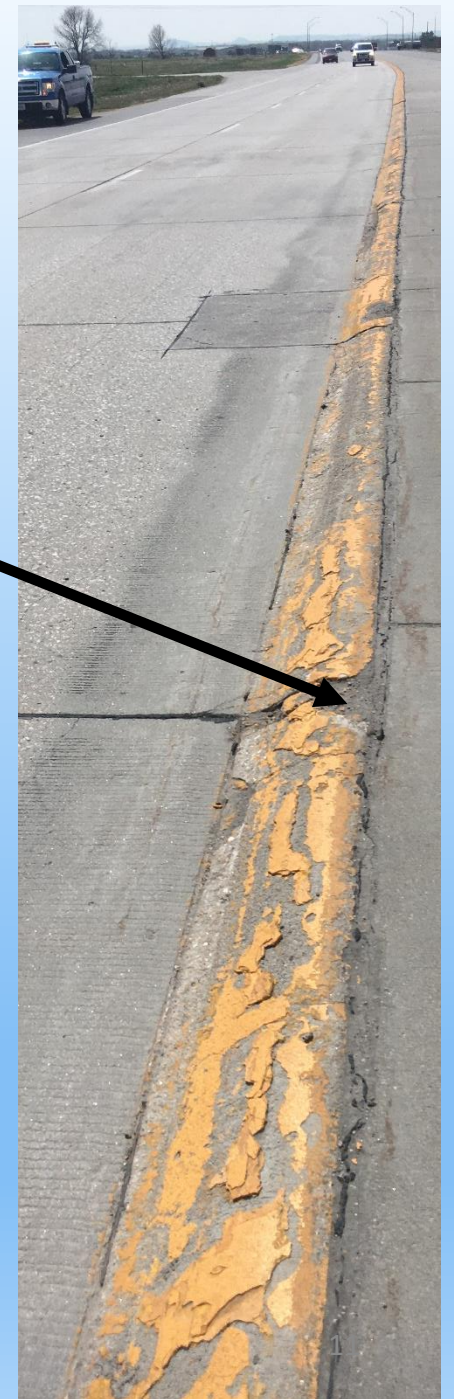

Photographs of Curb Repair

Drilling holes for tie bars and inserting tie bars requires room for the drill and the 18" bar. When possible, it's better to remove surfacing at the back of curb rather than sawing into the driving lane. However, easements and sidewalk improvement standards may limit options. Discuss the options with your Project Manager.

#5x18" Tie Bars Maximum
Spacing 48" or less Centers



INLET COVERS



Special Provision RECONSTRUCT CURB INLET

This work shall consist of removing the lid of the existing curb inlet at the location shown in the plans and replacing it with a new lid of similar design as the one removed.

The work will be measured as a single unit and shall be paid for at the contract unit price per each for the item “Reconstruct Curb Inlet”. This price shall be considered full compensation for all excavation, removal of existing materials , concrete, reinforcing steel, structural steel face armor, cast iron cover and frame, labor, equipment, tools, and incidentals necessary to complete the work.

FULL DEPTH REPAIRS (EXPOSED CONCRETE)

Shaded panel indicates where ASR extends back and ahead of each joint to the point that replacing half of all these panels is appropriate.



FULL DEPTH REPAIRS (EXPOSED CONCRETE)

Tie bars too close to surface.
At this point, no repairs are necessary. When bars are at the surface, and when they become a hazard, a partial depth repair may be necessary.



FULL DEPTH REPAIRS (EXPOSED CONCRETE)

Two thirds of panel shattered,
replace full panel



FULL DEPTH REPAIRS (EXPOSED CONCRETE)

It's often better to do one large repair rather than several small repairs.

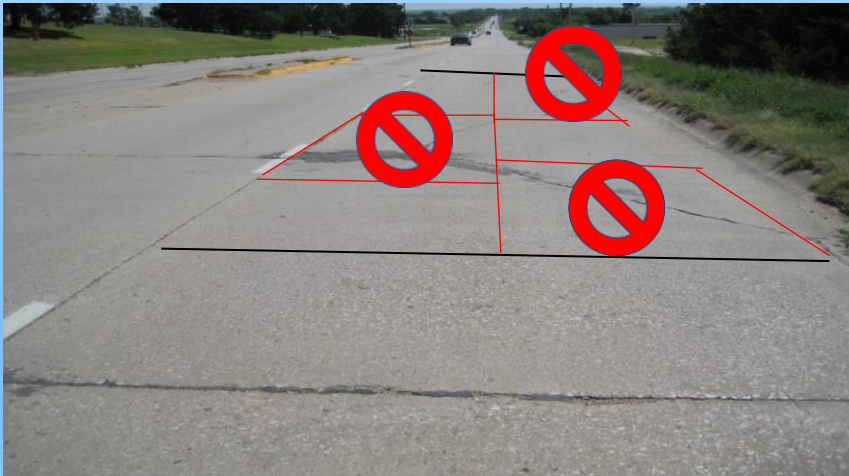

FULL DEPTH REPAIRS (EXPOSED CONCRETE)

Not a candidate for partial depth repair – unsound. In addition doing a repair within a repair is usually not a good practice

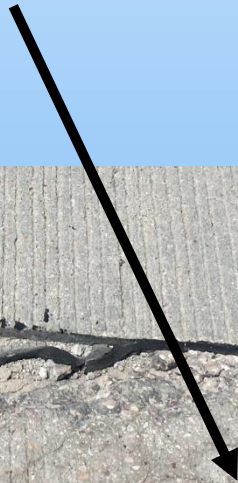

When older repairs need replaced, the size of the repair increases so that the saw is outside the existing steel.



FULL DEPTH REPAIRS (EXPOSED CONCRETE)



Pouring concrete repairs.

Subgrade is prepared for concrete repairs.



FULL DEPTH REPAIR (EXPOSED CONCRETE)

Removals, Preparation, and Construction



Options for dealing with adjacent asphalt shoulder :

- If there is no asphalt on the project, create a clean vertical face by removing deteriorated asphalt and extend the PCC into the asphalt shoulder.
- If project is milling and overlaying the shoulder, asphalt patching may be used to address locations with asphalt distress.
- Discuss with your Project Manager

FULL DEPTH REPAIR (EXPOSED CONCRETE)

BUCKLING

Buckling is caused by expansion without existing relief in the pavement.

- Caused by in-compressible sand or stones in the joints (re-sawing joints and hot pour sealant should address)
- ASR in the pavement – expansion joint may need added, discuss with pavement design.
- Thermal expansion properties of the aggregates in concrete can vary depending on the location in the state
- Whenever there is buckling it should be removed and replaced with a repair.



FULL DEPTH REPAIRS (EXPOSED CONCRETE)

- Concrete Repairs sized as Types A < 5 SY, Type B = 5 to 15 SY, or Type C >15 SY.
- Full depth concrete pavement repairs shall be a minimum of 4 ft. x 4 ft. so there is room to place tie bars, When there are multiple full depth repairs in the same panel, often it makes sense to replace the whole panel.
- If the distance to the next joint is less than 3', extend repair to avoid a gap < or = 3'.
- Replace panel when there are multiple intersecting cracks
- Saw cuts shall not encroach into the concrete beyond the repair.
- All saw cuts, transverse joints and longitudinal joints shall be cleaned with compressed air and hot pour sealant applied. Exception: Does not apply when concrete will be overlaid.
- Minimum length of repair is 4'.
- Minimum width of repair is 4' (exception: tapers have a minimum width of 2')
- Minimum width of repair to miss dowel bar retrofit is 4.5'-5'.
- Barrier and tack on curb and gutter replace integral with the repair

FULL DEPTH REPAIRS (EXPOSED CONCRETE)

Work to be done:

1. Saw cut to full depth and remove concrete pavement. Take care not to damage adjacent panels. Minimize over sawing. Wheel saws shall not damage the base.
2. Restore base and re-compact so that the repair depth is 2" greater than the existing concrete depth. Remove loose un-compacted material. Drill holes for tie bars and dowel bars within 1/8" diameter. (Do not replace wire mesh fabric)
3. Blow out holes, apply epoxy adhesive from APL, install tie bars and dowel bars.
4. Clean vertical surfaces with compressed air, install bond breakers where appropriate.
5. Install joint filler where appropriate.
6. Dampen the base.
7. Place, vibrate, finish and trowel concrete to match adjacent panels.
8. Surface should be flush with adjacent existing concrete and results in good ride quality. Trowel surface if it is not overlaid.
9. Apply curing compound from APL or tack coat if overlay follows.
10. Cover repairs with blankets or insulation board and plastic.
11. PR1 and PR3 Repairs can be opened to traffic at 3000 psi unconfined strength base on maturity or cores.

FULL DEPTH REPAIRS (EXPOSED CONCRETE)

SKEWED JOINTS

- When existing contraction joints are skewed, saw perpendicular to longitudinal joints so that dowel bars are parallel with the direction of travel.

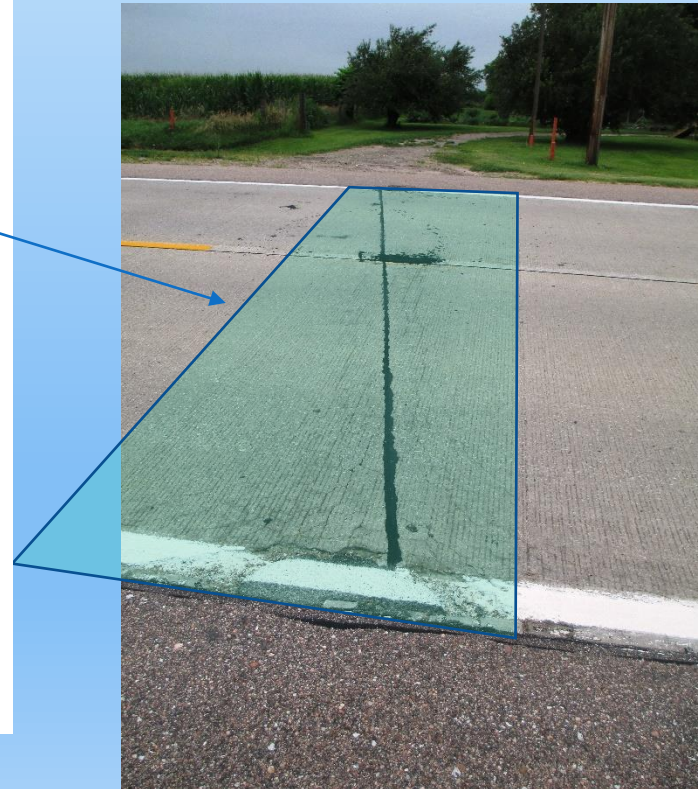
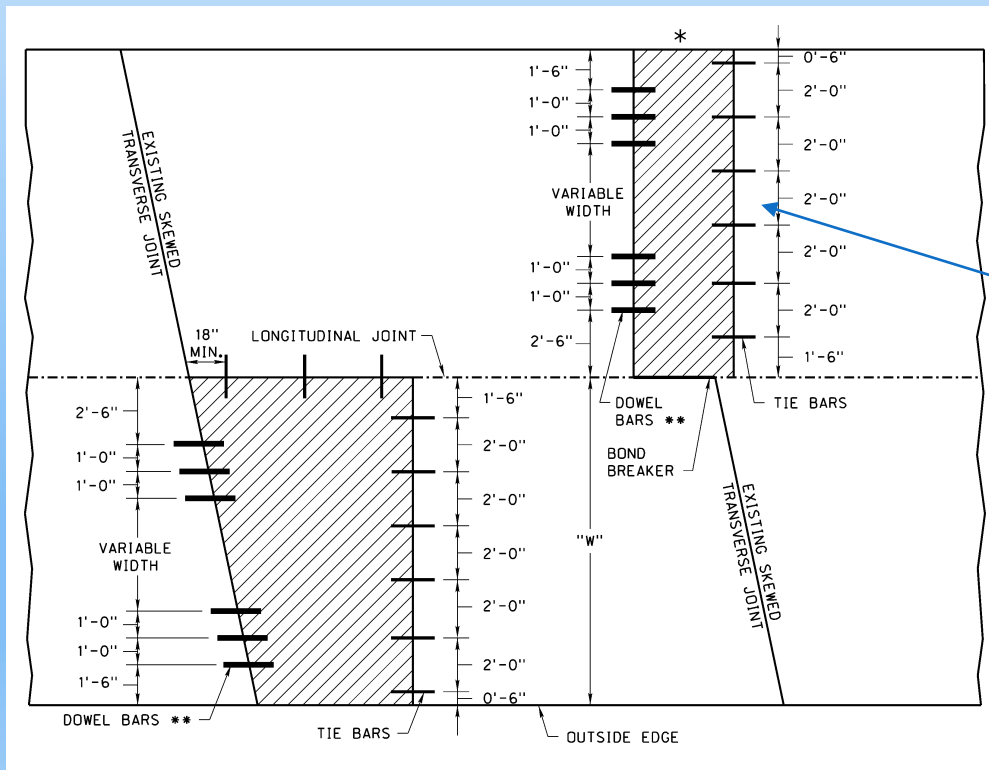

FULL DEPTH REPAIRS (EXPOSED CONCRETE)

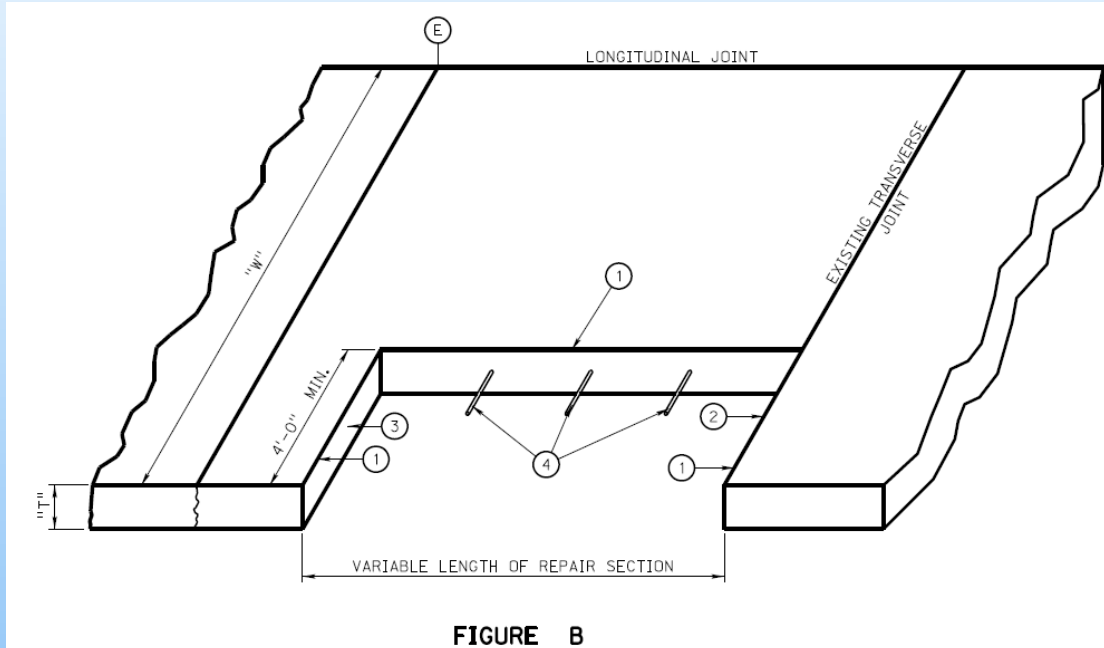

- ① FULL DEPTH DIAMOND SAW CUT (MAY NOT BE REQUIRED AT EXISTING NON-DOWELED TRANSVERSE JOINT).
- ② INSTALL DOWEL BARS AT NEW TRANSVERSE JOINT NEAREST TO EXISTING TRANSVERSE JOINT.
- ③ INSTALL TIE BARS AT NEW TRANSVERSE JOINT OPPOSITE OF DOWEL BARS. MINIMUM 2-TIE BARS PER SIDE.
- ④ TIE BARS REQUIRED, MINIMUM 2-TIE BARS PER SIDE.
- ⑤ IN THE CASE OF PANEL REPLACEMENT, DOWEL BARS SHALL BE INSTALLED AT EXISTING TRANSVERSE JOINTS. (3-DOWEL BARS PER WHEEL PATH.)
- ⑥ IN THE CASE OF MULTIPLE PANEL REPLACEMENTS, DOWEL BARS SHALL BE INSTALLED AT 12" CENTERS, AS SHOWN IN THE STANDARD PLANS. BASKETS SHALL BE USED ACCORDING TO THE STANDARD SPECIFICATIONS, SUBSECTION 603.03.

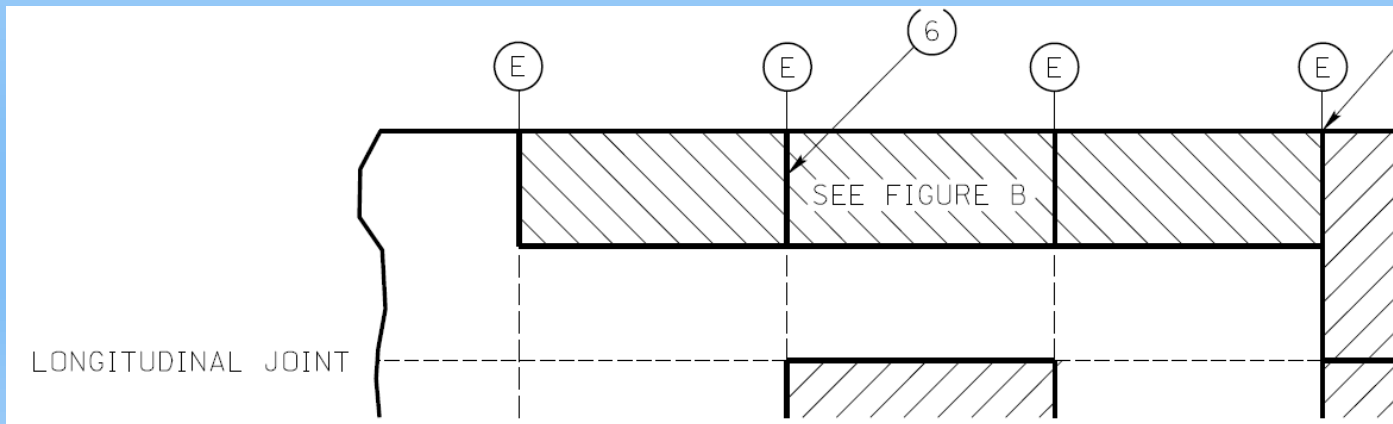

FULL DEPTH REPAIRS (EXPOSED CONCRETE)



Sawing Pavement



Removals



Skid loader with breaker



FULL DEPTH REPAIRS (EXPOSED CONCRETE)

Removal with chain and pins



When chain is loose, pins slide freely in holes

FULL DEPTH REPAIRS (EXPOSED CONCRETE)



Preparation of base with dynamic plate compactor



Drivers may need instruction not to damage the steel that has been placed.



Drill used for holes- minimum opening size is 4 ft.

FULL DEPTH REPAIRS (EXPOSED CONCRETE)

Dowel Bars must be placed parallel to each other. The intent of a dowel bar is to allow movement and transfer load from one panel to the next. The expansion joint in the photograph failed because the joint could not move.



FULL DEPTH REPAIRS (EXPOSED CONCRETE)



Smallest Full Depth Repair is a 4'x4':

- Limited base area for support, so a well compacted base that is drained is critical to longevity of this repair.
- Area of steel to support traffic is minimal
- If the soundness of concrete is susceptible or truck volumes are high this repair may not be successful.
- With the above conditions in mind a larger repair may be necessary

NOTE: Avoid overcuts when sawing to avoid future cracking and repair.

(This guidance is pending further review and testing in M&R)

FULL DEPTH REPAIRS (EXPOSED CONCRETE)



Sawing Pavement



FULL DEPTH REPAIRS (EXPOSED CONCRETE)



Vibratory Roller
Screed



When the initial set in concrete has occurred it's too late to try to float the surface. Don't allow the Contractor to spread water over the surface to aid in floating, this makes the surface susceptible to spalling.

Vibrators are required to consolidate concrete, however vibrators can cause segregation if they are allowed to staying running in one location too long. Don't drag a vibrator to move material. Vibrators should be stabbed vertically into the mix. Don't hold a vibrator next to a form.

FULL DEPTH REPAIRS (EXPOSED CONCRETE)



Finished Surface

JOINT REPAIRS (Exposed Concrete)

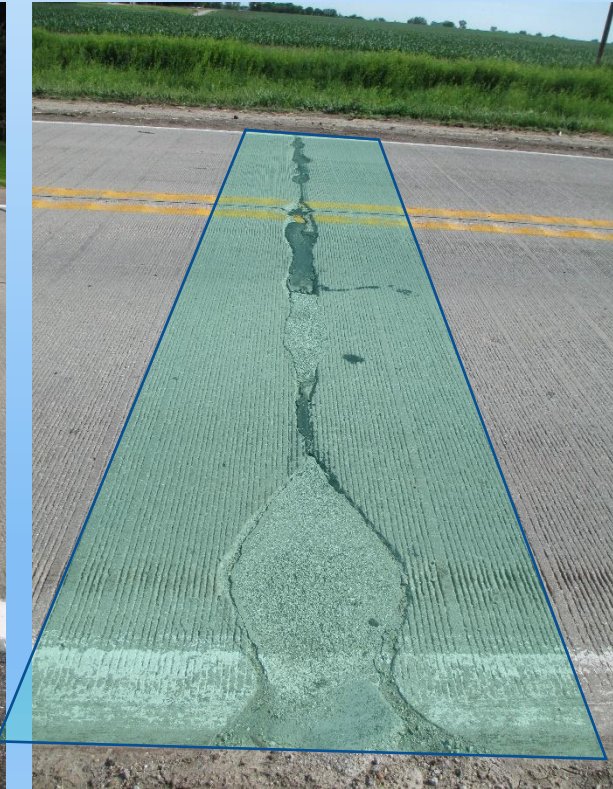
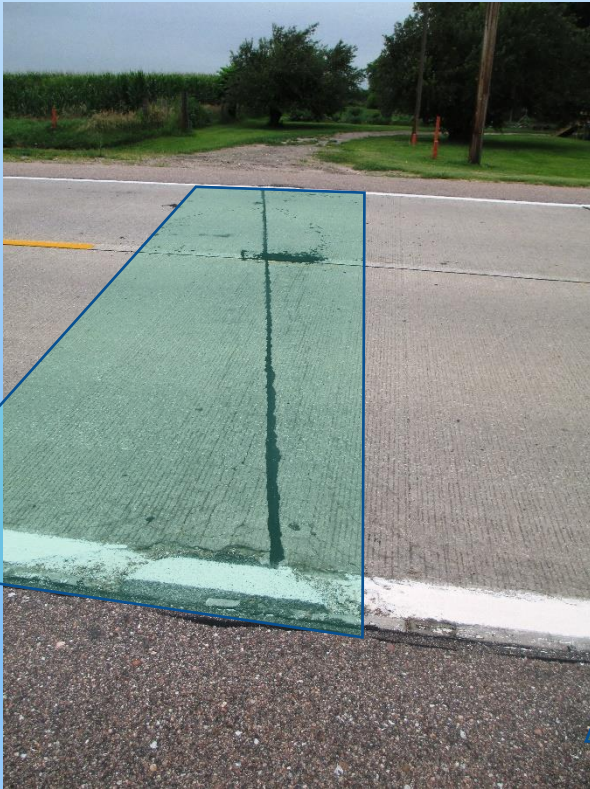

JOINT REPAIRS (Exposed Concrete)



JOINT REPAIRS (Exposed Concrete)

- Minimum length of repair 4'
- Minimum width of repair to miss dowel bar retrofit 4.5' - 5'
- Maximum longitudinal length of repair 9'
- Curb replaced integral with the repair
- Minimum width of repair 4' (exception: use minimum width of 2' so not extending into driving lane to get a 4' wide repair)

The work to be done is described in full depth repairs.



Don't make a joint repair in a narrow taper.

PARTIAL DEPTH REPAIRS (Exposed Concrete)

This partial depth repair is too small and could pop out.



Sound the perimeter of distressed concrete to confirm soundness



Minimum size is 2'x2' and avoid irregular shapes also too small



PARTIAL DEPTH REPAIRS (Exposed Concrete)

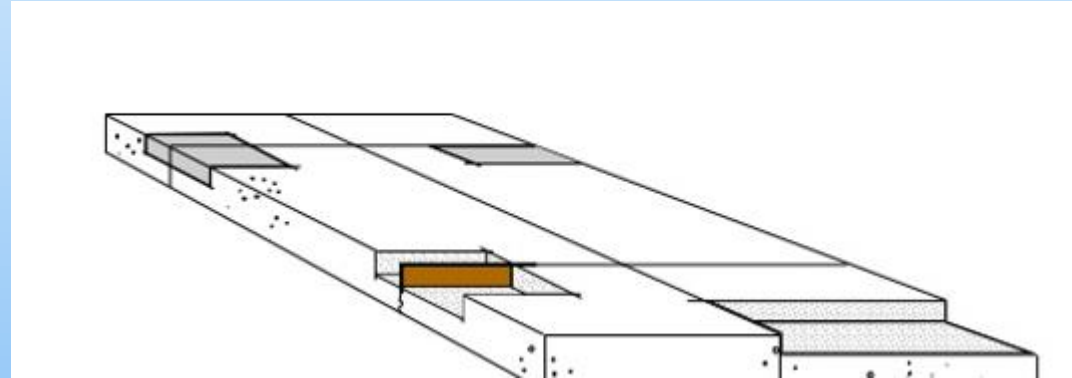

Mostly occur at joints but can occur anywhere
Most are type A or < 5 SY.

PARTIAL DEPTH REPAIR PLANS (Exposed Concrete)

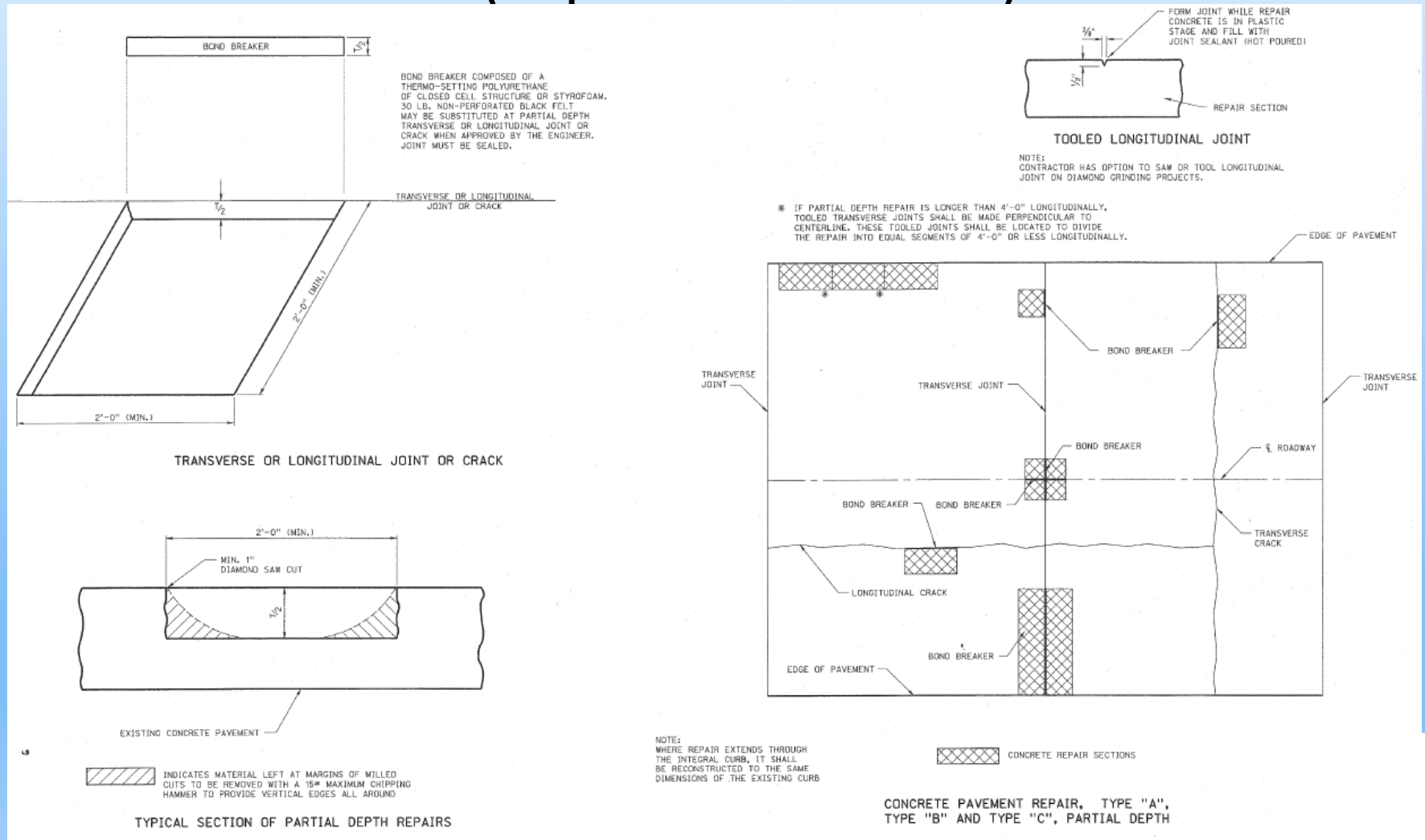

PARTIAL DEPTH REPAIR (Exposed Concrete)



Sound the area around the repair to determine if a partial depth repair is appropriate

Appropriate Partial Depth Repair

PARTIAL DEPTH REPAIR (Exposed Concrete)



What's wrong here?

- Over saws
- No joint tooled

PARTIAL DEPTH REPAIR (Exposed Concrete)



What should be corrected?

- Partial depth repair should not leave an adjacent area of distress.
- Re-establish the joint or a crack will develop



Removal to sound concrete. Apply epoxy to bond the partial depth repair.

PARTIAL DEPTH REPAIR (Exposed Concrete)

Extend repair to remove all distressed concrete, partial depth repair must have sound concrete on all sides or it will fail.



PARTIAL DEPTH REPAIR (Exposed Concrete)

MINOR SPALLS ARE REPAIRED WITH HOT POUR SEALANT OR MASTIC

Must be larger
than 5" to make a
repair.



<https://www.lrrb.org/pdf/201616.pdf>

PARTIAL DEPTH REPAIR (Exposed Concrete)



Partial Depth Repairs
should not be used to fix
a dowel bar retrofit

PARTIAL DEPTH REPAIR (Exposed Concrete)

Key notes:

- Length of joint distress should be 5" or more before considering repair
- Consideration should be given to where the spall is located; if its not in a driving lane, not in a wheel path then repairing with hot pour sealant may be best option.
- Minimum length of repair 2'
- Minimum width of repair 2'
- Attempt to limit repair length to just the panel. There are many exceptions.
- Do not use partial depth repairs next to stitching
- If more than 2' wide use a full depth repair.
- One side of repair must be 2'. Examples 2'x4' or 2'x100'.
- Do not perform a partial depth repair if partial depth repair does not get to sound concrete. If a partial depth repair can't get to sound concrete then a full depth repair would be required.

PARTIAL DEPTH REPAIR (Exposed Concrete)

Work to be done:

1. Diamond Saw cut.
2. Remove all existing concrete to the minimum dimensions shown in the plans or minimum depth of 3 inches and to reach sound concrete. Use chipping hammers (15# maximum) to form reasonably vertical faces.
3. Remove all loose material.
4. Apply epoxy bonding agent from APL to all surfaces.
5. Place concrete, re-establish joint or crack, apply curing compound.
6. Surface should provide good ride quality. Deviations greater than 1/8" should be corrected.



MEDIAN REPAIR (Exposed Concrete)

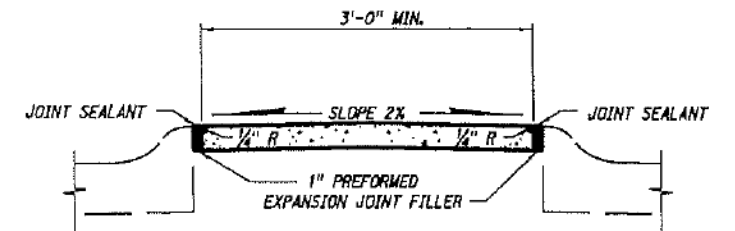

CONCRETE MEDIAN SURFACING

ONE INCH PREFORMED EXPANSION JOINT FILLER SHALL BE PLACED ACROSS THE FULL WIDTH OF THE MEDIAN SURFACING AT INTERVALS OF NOT MORE THAN 49 FEET.

LONGITUDINAL JOINTS ONE INCH DEEP SHALL BE MADE IN ALL MEDIANS WHEN SURFACING WIDTH IS 16 FEET OR GREATER.

TRANSVERSE JOINTS ONE INCH DEEP SHALL BE MADE IN ALL MEDIANS AT INTERVALS OF NOT MORE THAN 8 FEET.

TRANSVERSE AND LONGITUDINAL JOINTS SHALL NOT BE FILLED.

CROSS-STITCHING (Exposed Concrete)

Drill hole does not extend to bottom of slab

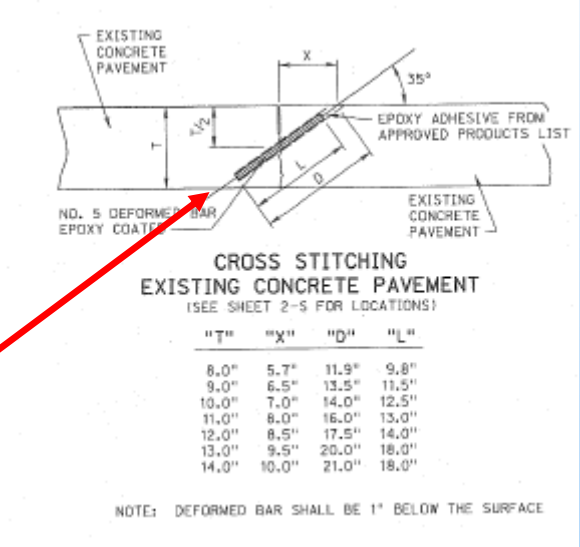

Sp. Prov.- Bars spacing =24"



CROSS-STITCHING (Exposed Concrete)

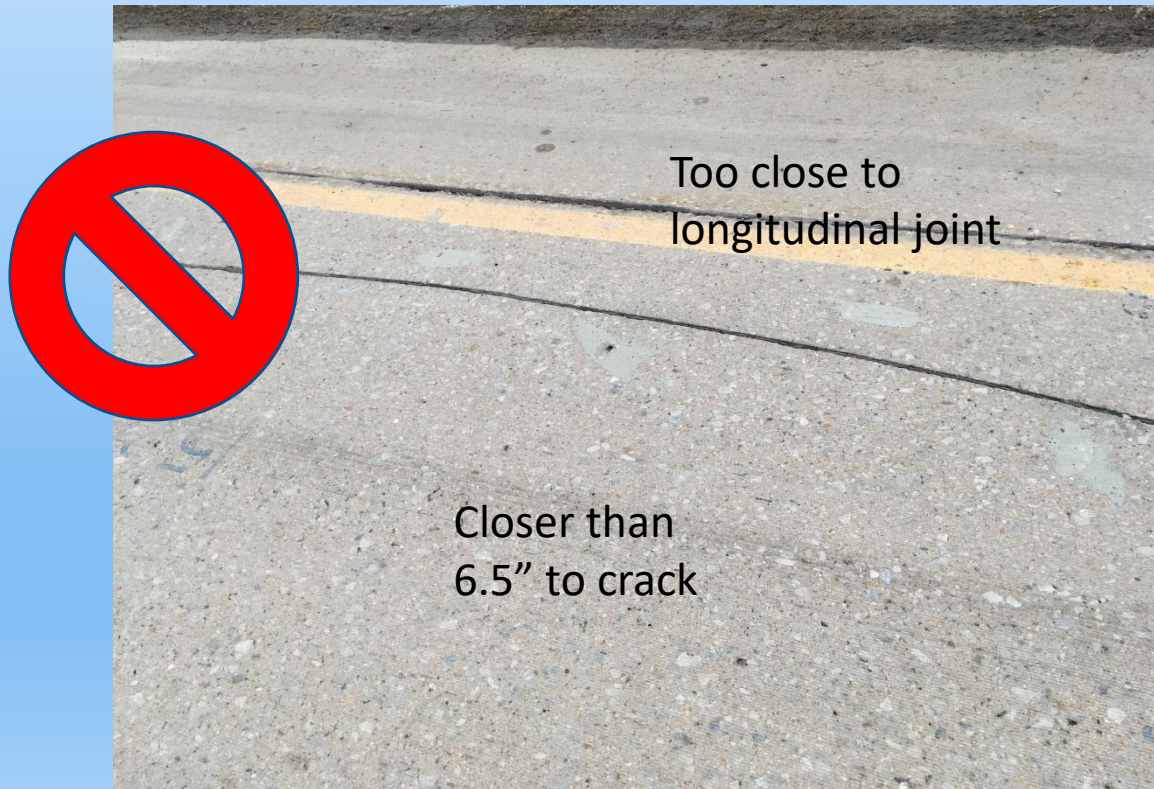

- Careful! Tie bars too close to crack cause spalling
- If angle is too steep additional longitudinal crack can develop

CROSS-STITCHING (Exposed Concrete)



Concrete too thin
for stitching <8"

Transverse Crack
If tight and no
spalling then no
repair necessary,
transverse cracks
are not stitched.



CROSS-STITCHING (Exposed Concrete)

Cross-stitching Candidate



Is this a good cross-stitch
candidate?

- Yes, tight cracks and sound concrete



CROSS-STITCHING (Exposed Concrete)



Good candidate for cross stitching up to here, then a full depth repair is needed.

Do not stitch transverse cracks

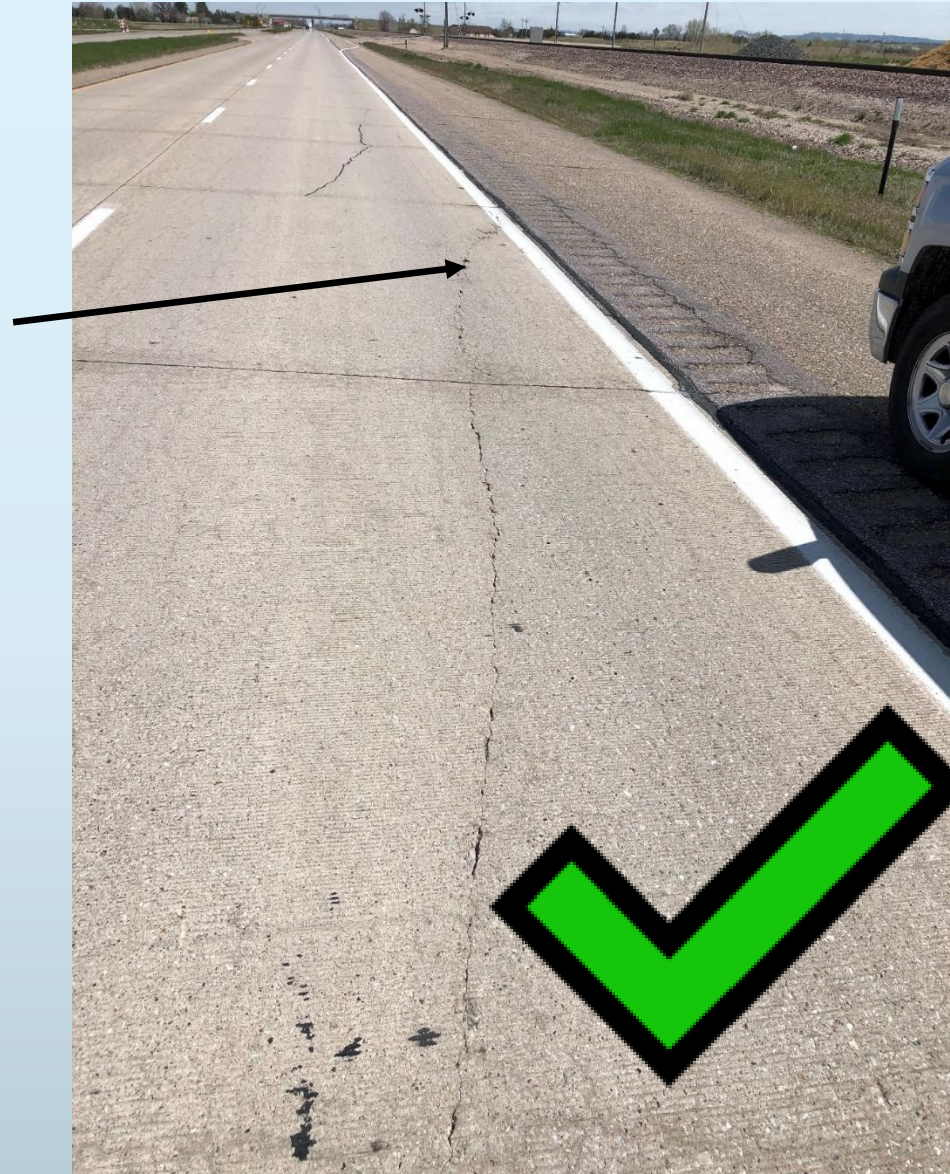

CROSS-STITCHING (Exposed Concrete)

Cross-stitching

- Not appropriate for transverse cracks, transverse cracks should be removed & replaced
- Not appropriate when other cracks are spider webbing off main crack
- Not appropriate when concrete has poor durability
- Not necessary in mesh or continuously reinforced concrete
- Used for cracks with elevation difference less than 1".
- Not appropriate when it's faulted and we decide it needs fixed; not necessary for composites
- Often not necessary for hairline cracks, crack should be a minimum of 1/8"
- Used for longitudinal cracks up to 2.5" apart
- Used to prevent further separation of joint or crack
- Careful to not drill through the bottom of the slab

Remove concrete instead of cross-stitching when

- Additional cracks come off the longitudinal crack
- Concrete durability is low

Cross-Stitching of a longitudinal crack not performed when

- The concrete thickness is less than 8", some exceptions
- The crack is stable and not running in the wheel track, then seal only
- Minimum length 4' of crack

CROSS-STITCHING (Exposed Concrete)

Inspection

- Drilling should not spall the surface
- Confirm the distance from the crack and the angle of the drill
- Confirm spacing of tie bar holes on each side is approximately 2'

CROSS-STITCHING (Exposed Concrete)

Is this a candidate for cross – stitching

- Yes, in most cases, cross-stitching and hot pour sealant will resolve up to 2.5”
- However, it is not a candidate if the concrete surface will get a thin lift overlay. The asphalt must be thick enough to bridge the gap. Instead, a full depth repair would be needed.
- Also, if the crack is faulted and a thin lift overlay is planned, then a full depth repair would be needed.

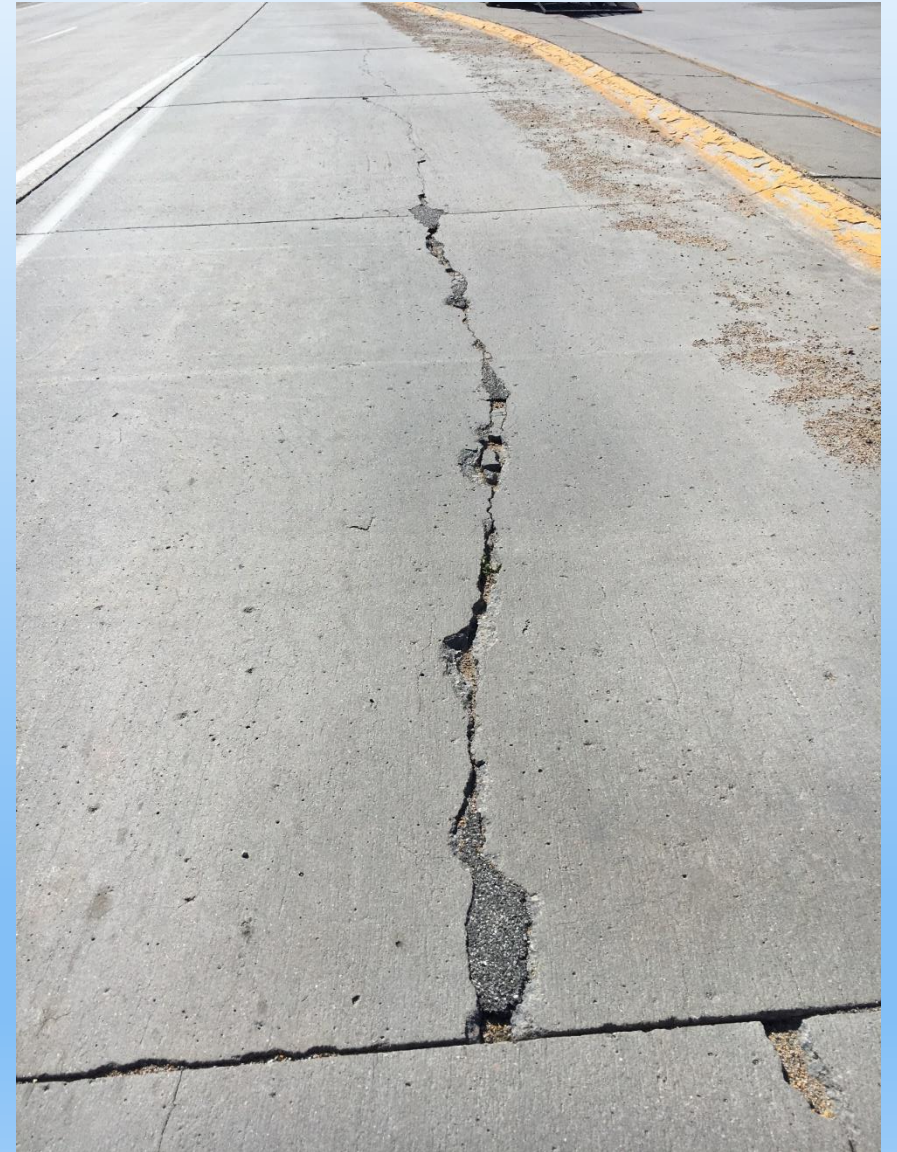

CROSS-STITCHING (Exposed Concrete)

Is this a candidate for cross-stitching?

- The portion in the blue box is not a good candidate. Material soundness is an issue.
- The crack in the yellow box may be a candidate depending on the thickness of the overlay.



CROSS-STITCHING (Exposed Concrete)

Repair needed.

Not in wheel path, address with cross stitching. Route and hot pour sealant applied if not overlaid.

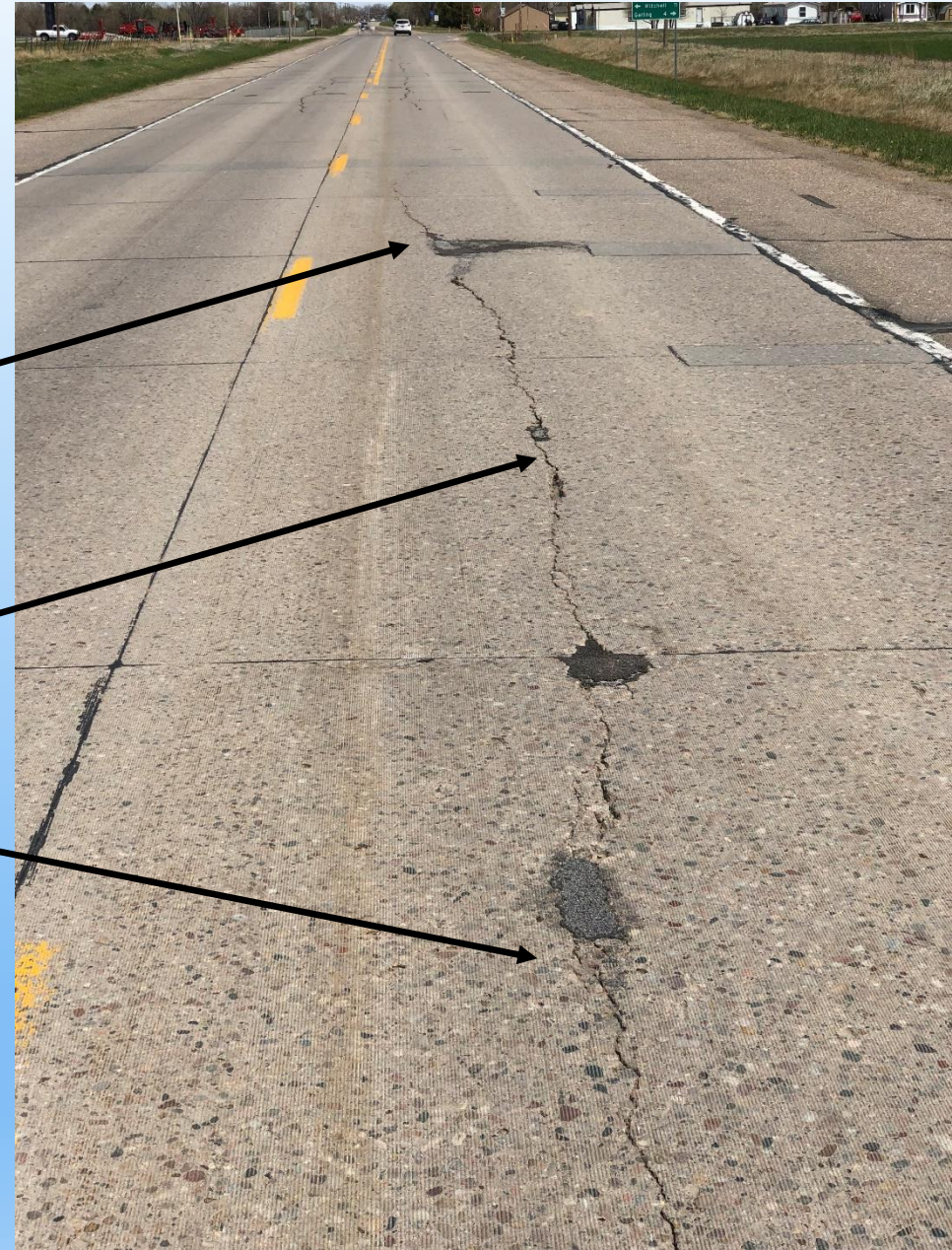

CROSS-STITCHING (Exposed Concrete)

When there is a noticeable elevation difference on the sides of a crack, can it be stitched?

- It depends where the crack is located.
- If it is in a high speed driving lane then it should be taken as a repair instead of stitching.
- If it is on the shoulder then most cracks with elevation differences can be stitched.



CRACKS WHERE NO REPAIRS ARE NECESSARY (Exposed Concrete)



Too Small



Crack is bound
No Cross-stitching

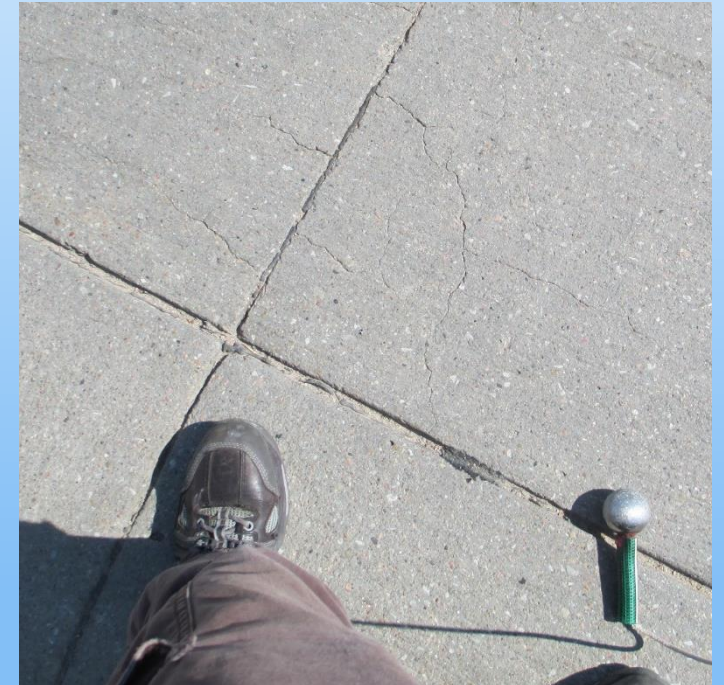

Too Small – but depends on sounding

CRACKS WHERE NO REPAIRS ARE NECESSARY (Exposed Concrete)

Crack length considerations: Is it stable? How open? Length alone not a criteria for stitching or repair.



Too Small



Too Small

Crack opening should be 1/8" wide or greater before considering a repair.

BEFORE AND AFTER CONCRETE REPAIRS (Exposed Concrete)



Avoid multiple pours in same repair
Avoid over-saws, especially with wheel saws

GOOD PRACTICES (Exposed Concrete)

Avoid Irregular Shapes

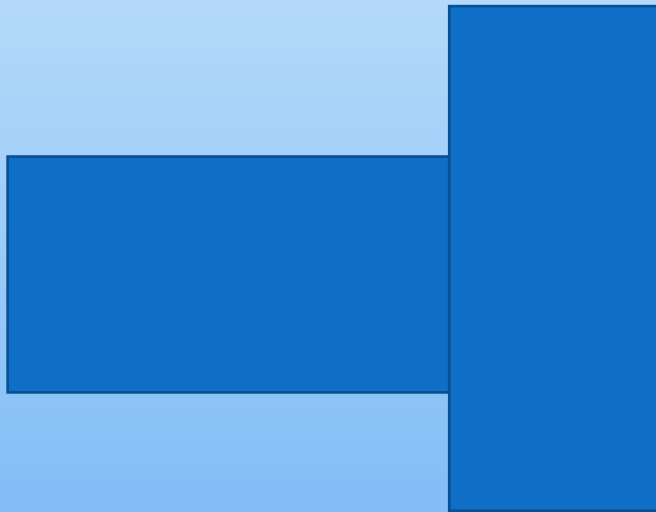
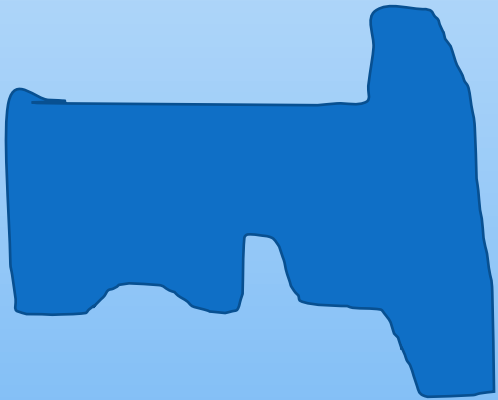

Rectangular Repairs are more Durable



Kangaroo



Horse



Buffalo

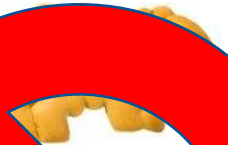

Sheep



Rhino



Bear



Pig



Camel



Hippo

GOOD PRACTICES (Exposed Concrete)



Avoid Feathers

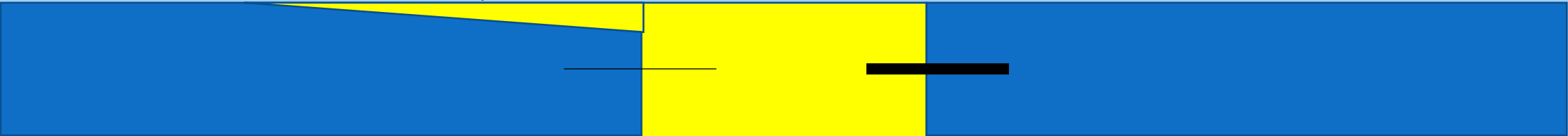
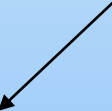

SPALLS (Exposed Concrete)

Partial Depth Repairs can be used to repair spalls when:

- Caused by incompressible material at joint
- Scaling is limited to upper one third to one half
- Adjacent to joints/cracks or corners

Partial Depth Repairs cannot be used when material deterioration exists

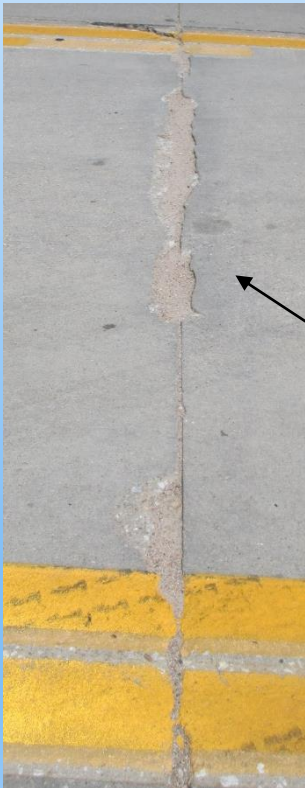

Evaluate material soundness consider hot pour sealant or partial depth repair

No Repairs needed, not driving lane, 5" or less. Hot pour sealant appropriate. (minimize use of PDR)



When pavement is overlaid with asphalt, minimize partial depth repairs at spalls.

SIDEWALKS (Exposed Concrete)

In many cases, sidewalk maintenance is a municipal function – discuss project scope with Project Manager

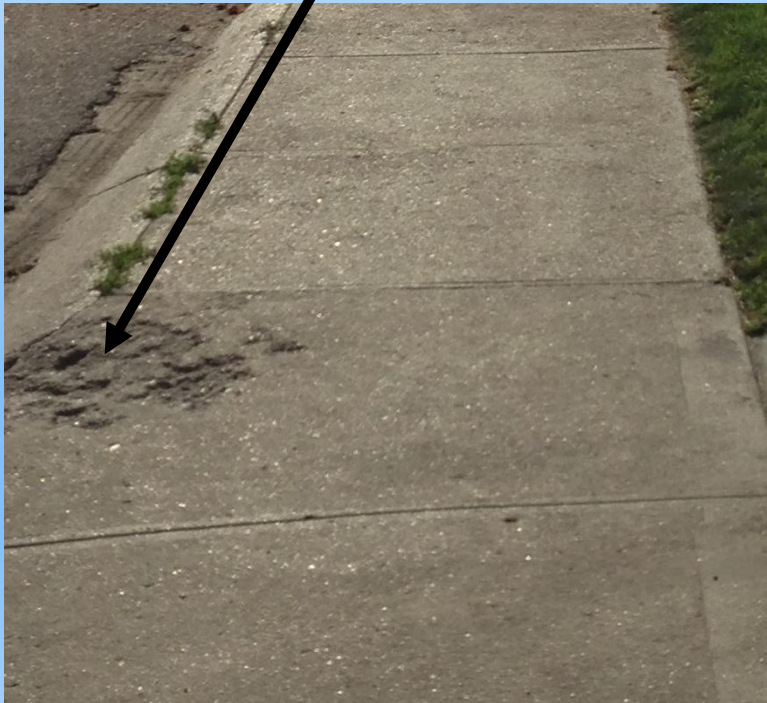

When the project does include sidewalks, eliminating tripping hazards is a priority; tripping hazards are defined as any projection over ¼"

ASPHALT OVER CONCRETE

- Composite Pavement (Asphalt over Concrete) does not have Partial Depth Repair, Joint Repair or Cross Stitching.
- Repairs focus on locations where there is evidence that the underlying base has failed such as:
 - Heaved Asphalt – sometimes milled by maintenance personnel or locations where combination tractor and trailer bounce is witnessed.
 - Sunken Asphalt – depression often with alligator cracking
 - Fines Visible - Wet soil fines are pumped onto the roadway surface
- Distressed Asphalt alone is not an indication a concrete repair is necessary.
 - Pushing is often seen when multiple armor coats cover a surface or when cold mix patch material is used.
 - Dry cracking is common as asphalt oxidizes over time especially when no surface treatments are performed.
 - Over time, depending on asphalt thickness, underlying joints will reflect to the surface, this is normal.

DISCRIPTION OF WORK (Asphalt over Concrete)

Concrete Repairs of Existing Composite Asphalt over Concrete

- Hot pour sealant is not used at repair locations just prior to an overlay.
- In most cases the order of work starts with concrete repairs poured flush with the top of the surrounding asphalt and then concrete patches are milled flush with the surrounding asphalt.
- Though the specification allows temporary asphalt to be placed over concrete repairs, this is rarely done. All temporary asphalt must be removed prior to getting an overlay.
- We pay for the concrete volume to the top of the asphalt even though it typically gets milled off. This is because improved efficiency and reduced lane closure time outweigh the material cost.

PREVIOUSLY CRACK AND SEATED (Asphalt over Concrete)

- Previously Crack and Seated (Existing composite roadway)
 - Repair only failures in roadway. Sunken or heaved locations
 - Wheel saw used to saw repair locations
 - Dowel bars/Tie bars are not permitted



Examples of
Underlying
concrete



COMMON DISTRESS (Asphalt over Concrete)

Repair is needed – Due to heaving and milling marks are an indication state forces have addressed in the past.



COMMON DISTRESS (Asphalt over Concrete)

Repair is needed – Due to sunken asphalt and previous patching



COMMON DISTRESS (Asphalt over Concrete)

Prior to Repair



Prior to Pour



REMOVALS AND PREPARATION (Asphalt over Concrete)



With composite pavements a wheel saw is the most common method of sawing.



Remove small debris by hand



Compact with dynamic plate compactor



Drilling holes for bars, single, or multi gang drills.



Drill holes at the midpoint of the portland concrete. Blow out holes with compressed air.

REMOVALS AND PREPARATION (Asphalt over Concrete)



Large scale removals



Remove small debris and level the base



Leveled and compacted base

REMOVALS AND PREPARATION (Asphalt over Concrete)



- Brittle asphalt can pop out caused by the removal operation.
- Prior to opening to traffic, a temporary measure may be necessary until the surface gets milled. Consider the risk to the traveling public when deciding what temporary measures are appropriate.
- If the problem is extensive, the PM may require an equipment change to minimize damage such as changing from a wheel saw to a diamond blade cut.

REMOVALS AND PREPARATION (Asphalt over Concrete) UNDER-CUT SPALLING

Drill and place bars at the midpoint of the existing PCC.



- Under-cut spalling is reduced by using a pneumatic chipping hammer of 15 lbs. or less.
- Under-cut spalling can also be attributed to concrete with low durability. Evaluate the pavement condition on your project to determine if removal practices need improved or whether the spalling is a material problem.

REMOVALS AND PREPARATION (Asphalt over Concrete)



If the length of the repair is 9'-0" or less and the width of the repair is greater than 6'-0. Construct a tooled longitudinal joint at the midpoint of the repair.



Placement of Bars in
the Wheel Path

CONCRETE PLACEMENT (Asphalt over Concrete)



Preparation and Pouring

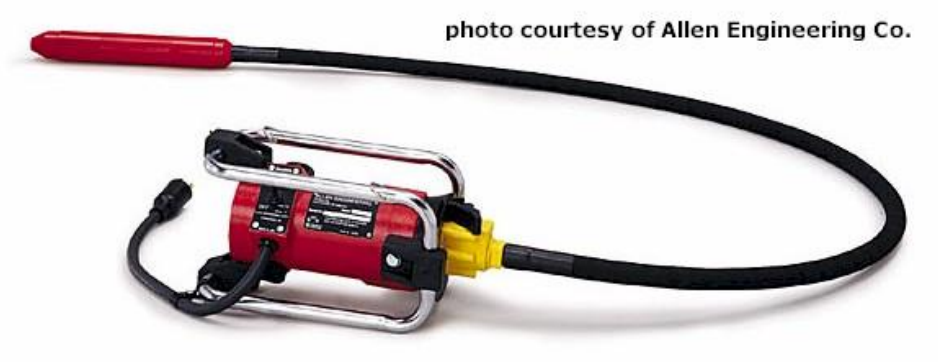
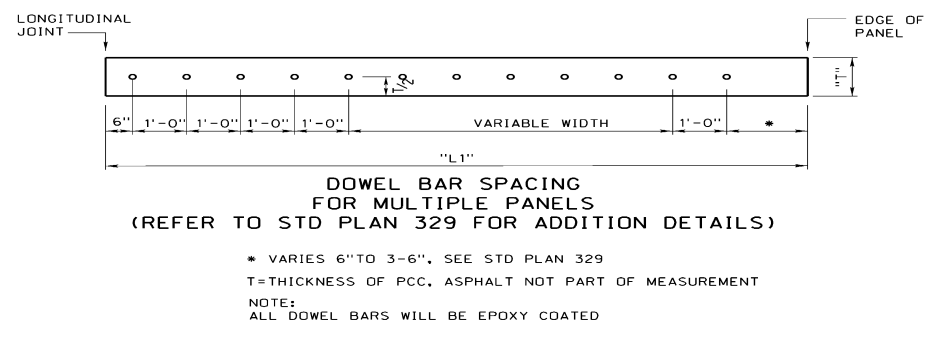

photo courtesy of Allen Engineering Co.

Vertical or Spud Vibrators are required to remove entrapped air. Honeycombing reduces strength and durability.

Multiple panels require dowel bars be placed at 12" centers



CURING & BLANKETS (Asphalt over Concrete)



Use of blankets is required to accelerate strength gain, however excessive heat can cause shrinkage cracks, monitor your project conditions



A rubber traffic cone base works well for holding blankets in place.



Curing compound is applied to reduce evaporation, it should be placed as soon as possible after finishing.

When exposed concrete is overlaid, tack coat can be used in lieu of curing compound.

BASE REPLACEMENT (Miscellaneous)

- Consider base replacement or rehabilitation when panels have settled
- Slabs are rocking or slabs are shattered
- After concrete removal, evaluate the base to determine if additional removal is necessary to provide support.

BASE REPLACEMENT (Miscellaneous)

General Guidelines:

605.04, 2a., (3)“Foundation Course Replacement” consists of removing and disposing of foundation course (i.e., bituminous, cement treated, crushed concrete, granular) or subgrade below the concrete pavement, which excludes the additional 2 inch of removal, as shown in the contract.

(i) When the Engineer determines that the foundation course and/or subgrade needs replacing, the Contractor shall remove and dispose of the foundation course and/or subgrade, prepare the subgrade, and replace the materials withn the same type of material.



BASE REPLACEMENT (Miscellaneous)

- The intent for making concrete repair depths 2” deeper than the existing pavement is to reach a load bearing subgrade that has not been disturbed by the removal process.
- If after removing 2” of material the underlying foundation course or subgrade is found to be unacceptable as a base then additional removal of foundation course and or subgrade is necessary. This is paid as Foundation Course Replacement and is included in every concrete repair project at 10% of the overall area of repairs.
- The pay item Foundation Course Replacement includes furnishing underlying soil with a similar soil and foundation course.
- Avoid using granular material to replace cohesive soil unless it’s possible to install subdrains. If it is possible to drain a repair area and the Contractor elects to use granular material, the expense of adding Granular Subdrains are the Contractors expense.
- A dynamic plate compactor is only acceptable for compaction of the top one inch of soil.
- Placement of soil should be limited to less than 4” lifts and compacted first with a rammer compactor and then with a dynamic plate compactor.

BASE REPLACEMENT (Miscellaneous)

There are times when base replacement can be omitted at the discretion of the Engineer.

- When the concrete repair size is one panel or less, perpetuating subgrade drainage is not necessary. In these cases, concrete can be placed on a stable subgrade without replacing the foundation course.
- When there is no existing foundation course beneath the repair, up to 4" of the subgrade can be removed and the opening filled with up to 4" of additional concrete in lieu of Foundation Course Replacement. Even if there is no existing underlying foundation course beneath the pavement, the pay item Foundation Course Replacement is used to pay for the work of removing the unsuitable base, and furnishing and compacting soil.
- Discussing Foundation Course Replacement at the preconstruction meeting can set expectations early in the project. The Contractor needs to be aware that cohesive soil that is unsuitable should be replaced with cohesive soil and granular soil should be replaced with a similar material. The Contractor must have a stockpile of foundation course and soil available in the event it is needed.

BASE REPLACEMENT (Miscellaneous)

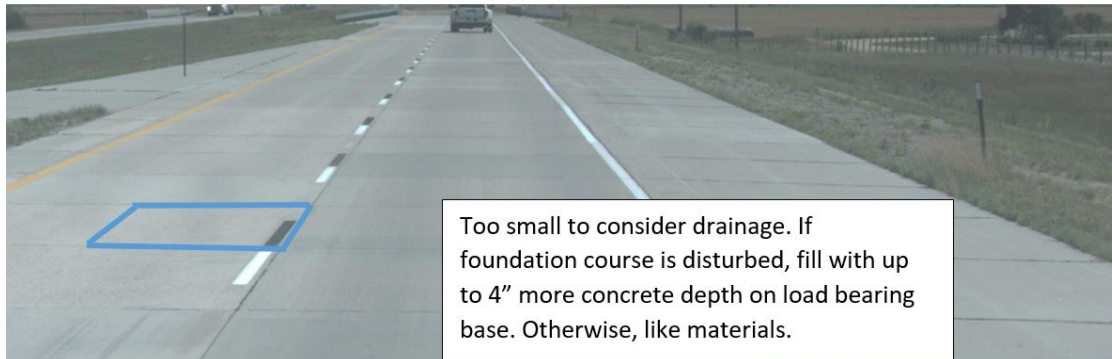

Too small to consider drainage. If foundation course is disturbed, fill with up to 4" more concrete depth on load bearing base. Otherwise, like materials.

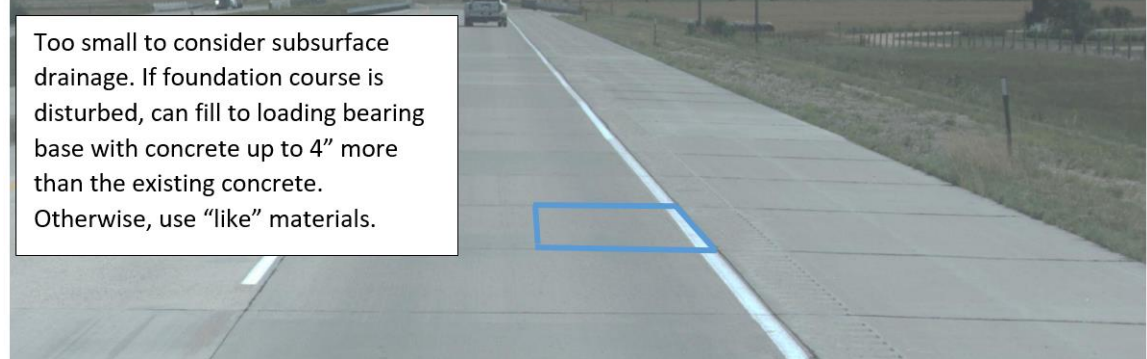

Too small to consider subsurface drainage. If foundation course is disturbed, can fill to loading bearing base with concrete up to 4" more than the existing concrete. Otherwise, use "like" materials.

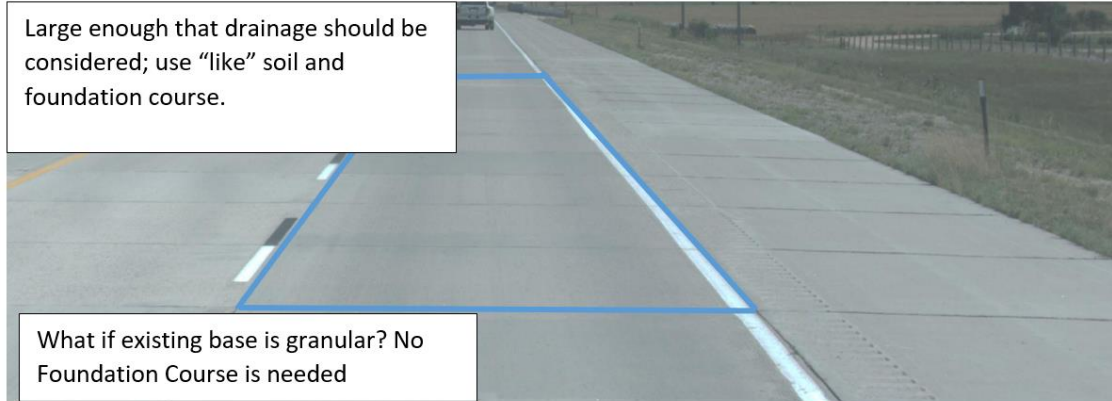

Large enough that drainage should be considered; use "like" soil and foundation course.

What if existing base is granular? No Foundation Course is needed

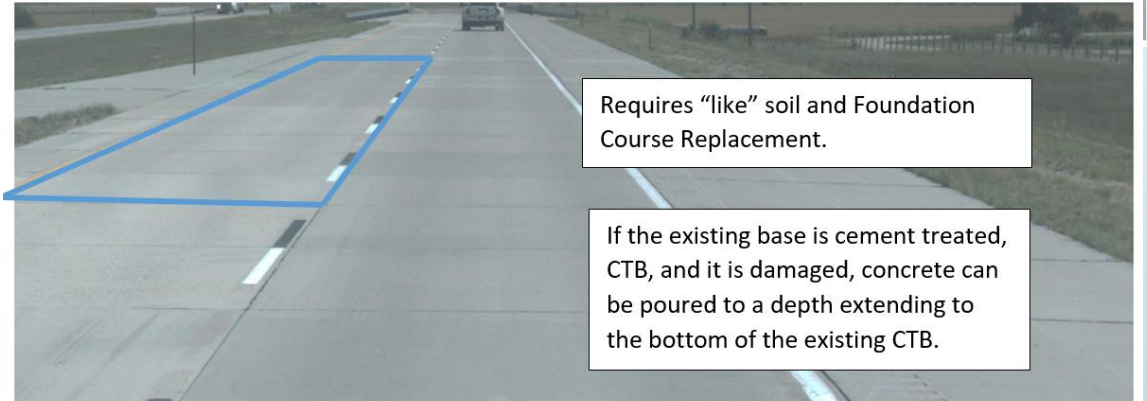

Requires "like" soil and Foundation Course Replacement.

If the existing base is cement treated, CTB, and it is damaged, concrete can be poured to a depth extending to the bottom of the existing CTB.

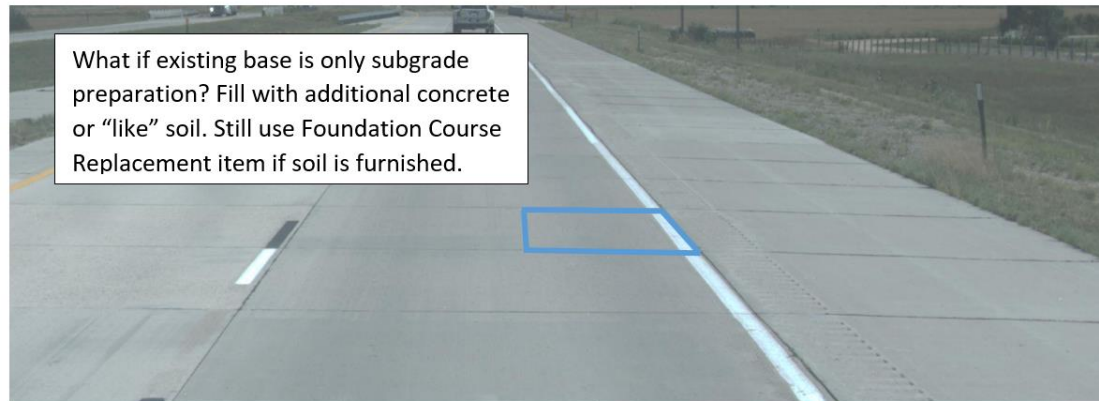

What if existing base is only subgrade preparation? Fill with additional concrete or "like" soil. Still use Foundation Course Replacement item if soil is furnished.

No distresses in this photo

BOND BREAKER (Miscellaneous)

No tie bars where a bond breaker is used.

A bond breaker allows adjacent slabs to move independent of each other.

⑦ LONGITUDINAL JOINT BOND BREAKER COMPOSED OF A THERMO-SETTING POLYURETHANE OF CLOSED CELL STRUCTURE OR STYROFOAM.

30 LB. NON-PERFORATED BLACK FELT MAY BE SUBSTITUTED AT FULL DEPTH LONGITUDINAL JOINT WHEN APPROVED BY THE ENGINEER. JOINT MUST BE SEALED.

⑧ BOND BREAKER WILL BE INSTALLED ON THE LONGITUDINAL JOINT BETWEEN THE NEW DOWELED JOINT AND THE EXISTING TRANSVERSE JOINT.

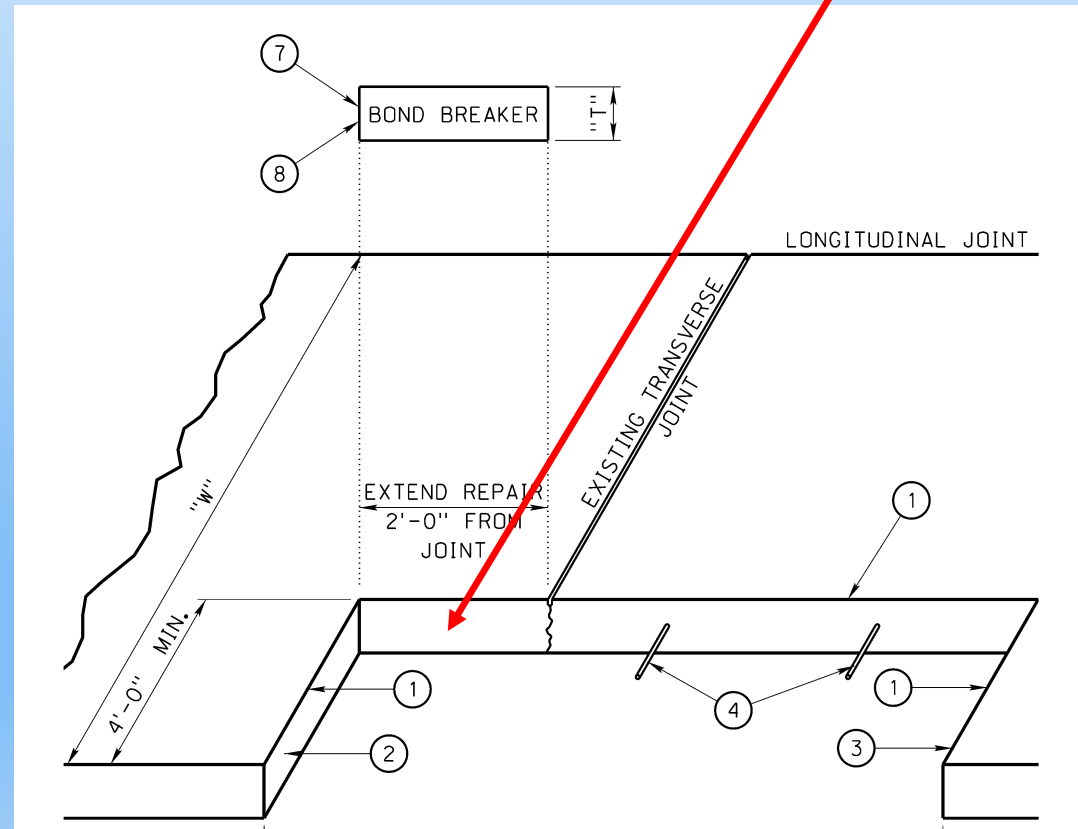

BOND BREAKER (Miscellaneous)

- Thermo-setting Polyurethane Bond Breaker is needed when an isolation joint is desired. Typically used with median surfacing or when sidewalk abuts back of curb or driveway abuts pavement.
- Typically 30 lbs. non-perforated black felt is used at longitudinal paving joints to prevent bonding.
- When full depth saw blades bind up as a result of high pavement temperatures, the Contractor should evaluate weather conditions and possibly use more equipment if necessary and perform sawing operations in the morning.

SEALING REPAIRS, JOINTS AND CRACKS (Miscellaneous)

Sealing Cracks in Concrete

- The typical minimum crack openings should be at least $\frac{1}{4}$ " to seal.
- If the opening is less than $\frac{1}{4}$ " use your judgment.
- Hairline cracks should not be sealed.

Sealing Joints

- Remove existing joint sealer and cleanout the joint.
- Re-apply joint sealant.

Joint Sealing Asphalt to Concrete

- This pay item is not used when a new asphalt overlay is placed next to concrete.
- This pay item is used when the mainline is getting repairs and sealed and the joint between the asphalt shoulder and concrete mainline is resealed.

SEALING REPAIRS, JOINTS AND CRACKS (Miscellaneous)

- The pay item, “Sealing Concrete Repair Joint” refers to sealing an existing repair not bordered by a transverse or longitudinal Joint.
- If the concrete repair is done with the current project then sealing at a repair location is subsidiary to the repair.

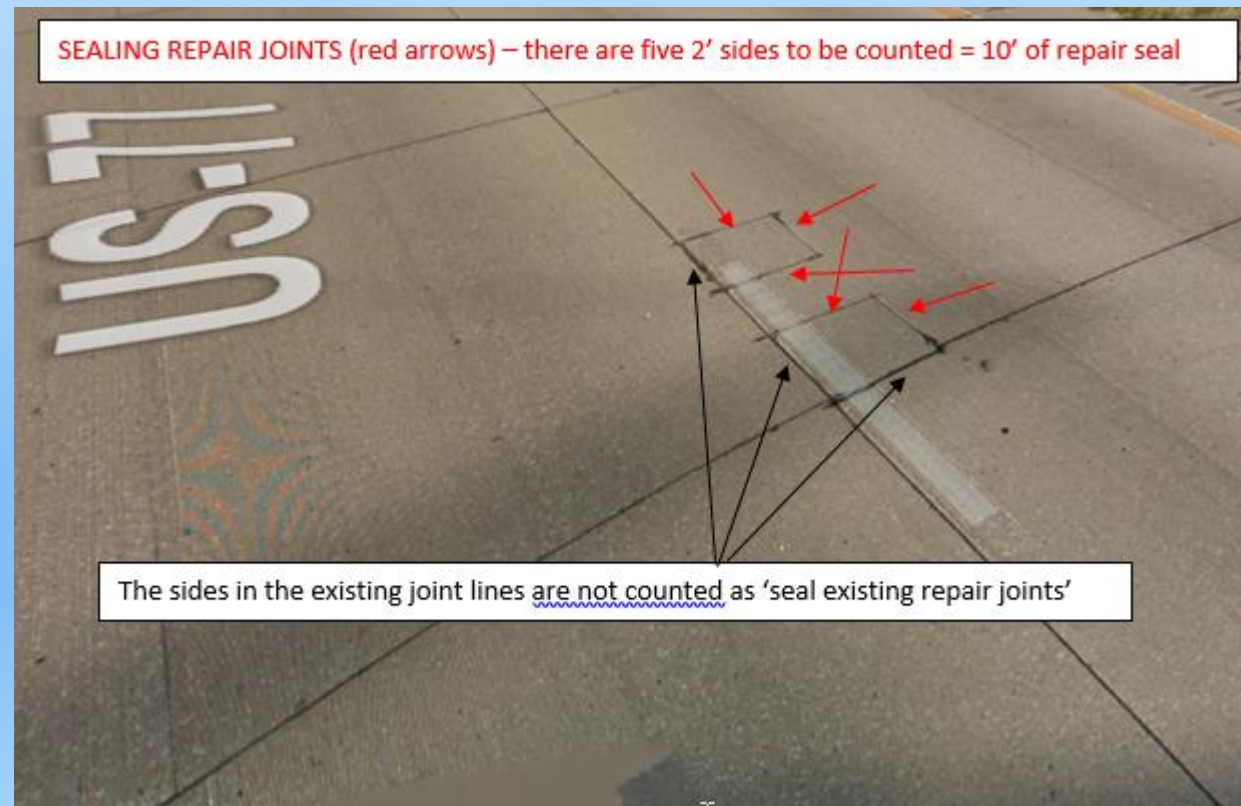

SEALING REPAIRS, JOINTS AND CRACKS (Miscellaneous)



Hot Pour Sealing Joints

SOUNDING PAVEMENT (Miscellaneous)



Sounding is used to identify delamination in exposed concrete. Pavement is sounded by dropping a steel ball or hammer on the concrete surface and listening to the pavement response.

- A high pitch sound means the delamination is shallow
- A deep drum sound is an indication distress is deeper perhaps a full depth repair is more appropriate.
- Don't confuse the sound adjacent to a joint for the sound of delamination. Practice on a joint that's known to be solid.
- If delamination is identified, then the repair location needs delineated by sounding the area until solid pavement is found. If the partial depth repair is within 2'-3' of another partial depth repair, consider increasing the partial depth repair dimensions.
- Chaining is another option for identifying delamination or pavement with soundness issues.

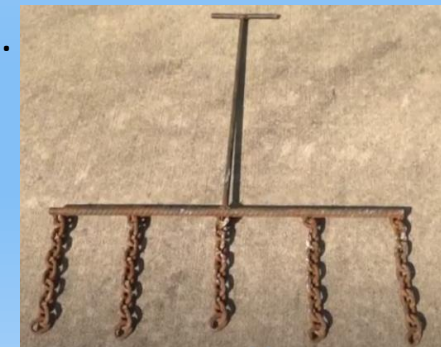

NUMBERS TO REMEMBER

(Miscellaneous)

Sawing Joints

- $T/3 \times 1/4$ " Saw Depth and width when new concrete on both sides of cut
- $T/3$ (3" max.) Saw Depth to remove joint sealant, width up to $1/8$ " wider than existing
- $1 1/4$ " Minimum cut depth, Early Saw Depth when new concrete on both sides of cut

Formed Joint While Plastic

- $1/2$ " deep x $3/8$ " wide

Joint Existing Concrete and New Concrete Abut

- $1/2$ " deep x $3/16$ " max width saw cut
- $1/2$ " deep x $3/8$ " width while plastic

Partial Depth Repairs

- Do not saw the perimeter of partial depth repairs after curing. Partial depth repairs are bonded with epoxy.
- Minimum depth of 3" or $T/3$ whichever is greater.

EPOXY USED IN CONCRETE REPAIRS (Miscellaneous)

The types of epoxy used in concrete repairs are described in Section 1018.

Type I is used for epoxy of tie bars and dowel bars to concrete

Type II is used for epoxy of hardened concrete to partial depth concrete repairs

Some of the products on the Approved Products List can be used for both Type I and Type II applications.

Advise the Contractor it is his/her responsibility to chose the Grade that will not run off a surface or out of the hole and the temperature Class for climatic conditions encountered.

HISTORIC STEEL PLACEMENT (Miscellaneous)

Transverse sawing should occur 2' from the transverse joint in the following cases:

- 60s and 70s Reinforced Concrete has 18" dowel bars and mesh 2.5" from the surface
- Plain Doweled Concrete has 18" dowel bars
- This does not apply to panels replaced on N&R projects

Non-Doweled Concrete Pavement

- Saw at existing transverse joint if it bounds a concrete repair.

Parabolic Concrete thickness of 9"-6"-9" and 9"-7"-9" (mostly widened with PCC), there are no dowel bars at the transverse joint

- Wire mesh continues through transverse joint, it was placed 2.5" from surface
- Saw at existing transverse joint if it bounds a concrete repair, however rarely visible today mostly composite.

Parabolic 11' wide concrete

- No Dowels and no mesh. Saw at existing transverse joint if it bounds a concrete repair.

Examples: M&R Field Survey



US-283 (57.70 to 58.0) & (Ash St. to Washington St.) Looking west in the NB at three repairs: a 9'x 12' repair in the left turn lane and the inside panel, a 9'x 14.5' repair in the outside panel. All with open or faulted cracks. From 2009 – Why take these areas? With a large solid existing repair on the left that has no indications of any needed repairs – the 'continuation' of the repair area makes the most sense with open 'Y' & 'T' and Transverse cracks.



#2 US-283 (57.70 to 58.0) & (Ash St. to Washington St.) Looking north in the NB outside panel, outside edge at a 67'x 6.5' repair that includes the integral curb. Why repair and not stitch? Note the staining adjacent to the longitudinal crack – the stitching bars may not hold on this stretch due to loading (US- 283 In Lexington – truck route!). Adjacent broken curb is included in the full depth repair.

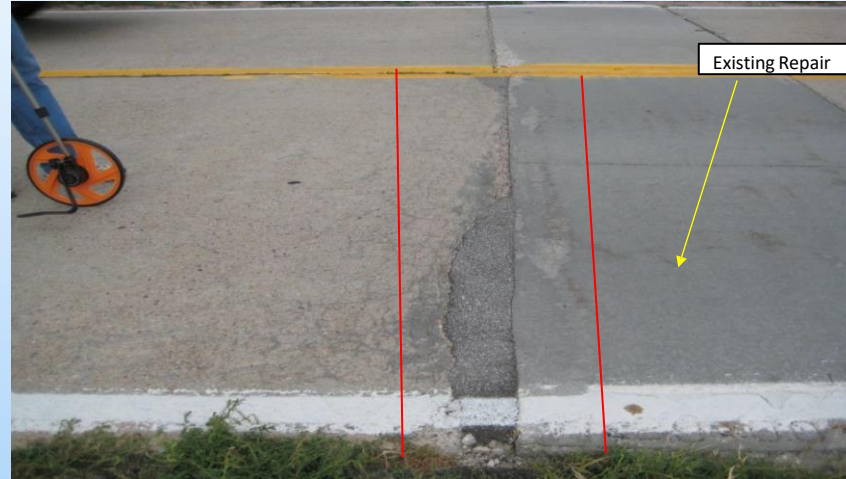

#5 US-30 (108.0 to 109.0) Looking north in the EB at a 4'x 12' full depth repair adjacent to the existing repair with AC patching and small amount of delamination. FROM 2010 - Why Repair? The existing repair is solid and the adjacent area could be repaired with a partial depth repair instead of a full depth. Bit patching would be acceptable here also if to be overlaid. Using a full depth repair may negate dowel bar placement depending on which side dowels were placed into if an existing joint



#6 US-30 Looking north in the WB at a 7'x 12' joint repair that includes existing repairs, area milled with AC patching. Note the cracked delaminated partial repair in EB inside edge. Area with red lines has failed with multiple AC patches – always list this type of area for removal – cracked partial was listed to be repaired with another partial depth repair. If to be overlaid may just leave the partial...



#7 US-30 (450.44 to 450.0) WB Looking west in the WB outside shoulder, inside edge at a 95'x 4' repair with spalls, staining, cracking, AC patching, and delamination. Note the 24' top will be rebuilt. 2009 - Why repair? Since mainline is to be rebuilt the shoulder needs to be able to be tied into the new adjacent pavement – patched areas and staining indicate that the inside edge needs to be repaired to prepare for the tying of the new pavement.



#8 L-31D (1.18-1.09) In Franklin - Inlet, broken lid is 10' wide w/8" solid concrete in middle. 2014 – This is one of the odd inlet covers in D7 – looks like was made in 3 pieces - Look at how low the lid is to the inlet throat. Has been replaced as of 2020 with new ADA ramp installation.



#9 L-31D (1.09-0.87) In Franklin - inlet lid, 6' wide (NE radius at 12th Ave.). This lid was listed for replacement but the lid face was repaired with grout instead (per google maps)



#10 US-136 (52.41-52.24) In Franklin WB-OP, NW radius at 18th Ave., looking west at 20' x 18' repair needed. This needed repair is in a intersection radius and should be poured in one patch area. Avoid making several smaller patches to make the larger repairs especially in turning areas.



#9 I-80 EB (201.0 to 202.0) Looking northwest in the EB driving lane, outside edge at a 4' x 5' joint repair with a AC existing repair and note the 2.5' x 2' partial depth repair in the outside shoulder. **Why repair? Partial depth in retrofitted area sunk and has been replaced with AC. The outside shoulder inside edge is delaminated but not spalled – partials are not allowed in retrofitted area.**



#12 I-80 Looking west in the WB passing lane at two more odd repairs with 1.5' left in between the two existing repairs. This area will not be repaired at this time (no delamination). Why not repair? Other than the staining there is nothing 'wrong' with the area – just odd repair placement.



#13 I-80 WB (202.0 to 201.0) Looking west in the WB passing lane, middle of lane at a 137'x 5' full depth repair with spalls, delamination, and staining. **Why repair? The cross stitching holes are all delaminated and will need repaired – spalls starting to show on crack - this area will begin to break out**



#14 N-2 (287.0 to 287.35) Sta. 424+03 PRJ open 1 1/2" and doing 5' x 24' joint repairs. **Why repair? The old way was to remove all these pressure relief joints as they were encountered – I was never given a good reason why these needed to be removed. I leave them alone if no other issues involved. Note if open 6" plus than consider a repair/ removal.**



#15 I-80 EB (219.0 to 220.0) Looking west in the EB driving lane outside edge at a 105' x 5' repair (purple lines) with a longitudinal crack with delamination. Note 2' x 2's in the OS inside edge (red arrows)... **Why repair? Longitudinal crack is in the outside wheel track running thru the retrofit slots with staining and delamination. Small partial repairs on outside shoulder need to be sounded before deciding if a repair is needed in the area.**



#16 I-80 EB (220.0 to 221.0) Looking west in the EB driving lane at a 21' x 12' repair (red lines) and a 39' x 5' repair (black lines) in the outside edge. Note the odd shaped repair – purple lines (like bottom of lower case 't'). **Why repair? Odd shaped repair is partially in wheel track plus cracking and staining. Cannot remove odd shaped repair without going into retrofit slot on left.**



#19 N-103 RP 56.40 Looking north in the NB at a 12'x 4' & a 12'x 12' repair and Exposed Concrete to Full Depth Asphalt... 2010 Why repair? Repair area is at transition from concrete to full depth asphalt and diagonal crack in repair area may be due to this. Crack is should not be stitched due to transition.



#20 I-80 Exit #231 Darr Interchange Looking up Eastbound on ramp at all the repairs painted and rotten AC shoulder. 2008 Exposed Interstate ramps should be repaired – these are essential to moving of traffic on and off the interstate –also hard for maintenance forces to repair w/o backing up traffic.



#21 N-92 (411.0 to 411.67) Looking east in the WB outside edge at a 35'x 7' repair with a 1" open longitudinal crack, faulted, and spalled. 2010 – Why repair? Open faulted crack with no concrete shoulder and panel is sunk (red arrow) and has asphalt patching (yellow arrow).



#22 N-10 (47.34 to 47.71) Looking south in the NB outside edge at a 32'x 5' repair with a delaminated crack and a 16'x 12' repair in the NB at the spall (red arrow). 2010 Why repair? Longitudinal crack has areas that are breaking up and is not stitchable. At the I-80 Interchange...

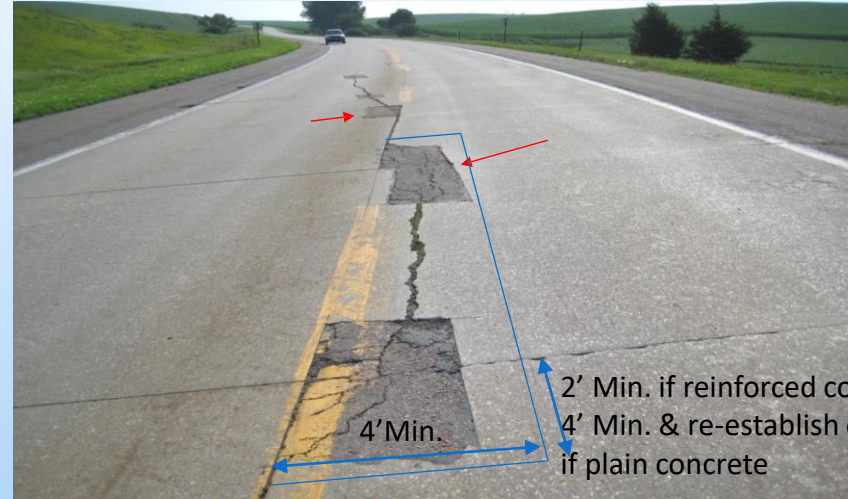

#23 N-35 (52.0 to 53.0) Looking east at repairs in the EB & WB inside edge (centerline area) that includes the AC existing repairs. 2011 Why repair? With asphalt patching in the exposed section we try to remove the AC patching and replace with concrete for uniformity. Crack was removed with repairs.



#24 N-35 (56.0 to 57.0) Looking west in the WB outside edge at a 45'x 6' repair that includes the AC existing repairs also adjacent to this repair is a 50'x 7' repair (red arrow). 2011 Why repair? With asphalt patching in the exposed section we try to remove the AC patching and replace with concrete for uniformity. Crack was removed with repairs.



#25 US-6 (309.0 to 309.15) Looking west in the WB at a 40'x 11' repair with large pot holes and AC patching. NW 56th St. is just behind this picture. 2011 Why repair? Large pot holes w/ possible longit crack under asphalt in same area. Remove full under pavement width (11'). Alternate I-80 route...



#26 N-31 (26.0 to 27.0) Looking north at a AC 'scab' that was milled before the asphaltic concrete (AC) was laid. This area will require a 90'x 24' repair/ replacement before diamond grinding... 2012 Why repair? If this was an asphalt overlay project we would just walk away from it but the scope is diamond grinding – since we do not diamond grind asphalt it must be removed for uniformity.

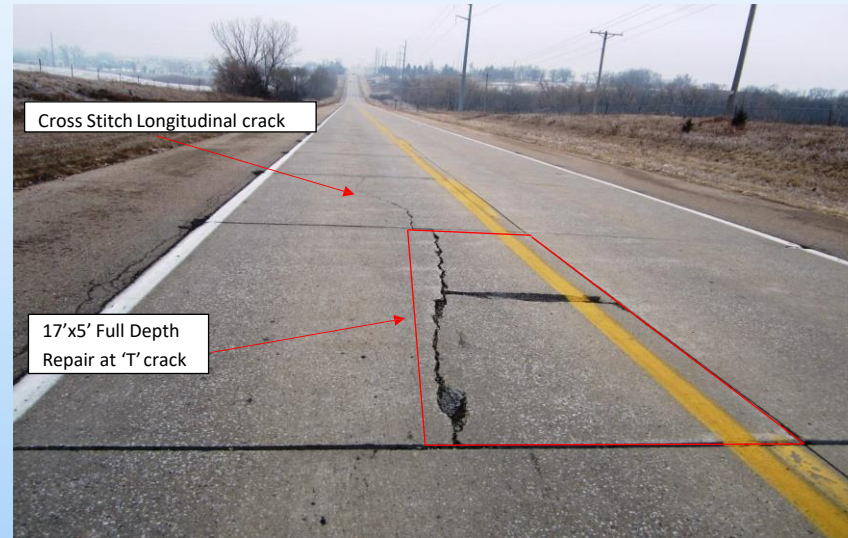

Cross Stitch Longitudinal crack

17'x5' Full Depth Repair at 'T' crack

#27 N-31 (26.0 to 27.0) Looking south in the NB lane at one panel to be stitched and one 17'x5' repair. Several cracks were in good shape and have been listed for stitching. 2012 Why repair? 'T' Crack in the foreground panel has to be repaired. Adjacent panel can be stitched.



#28 US-275 (20.75-21.0) Looking east, inside panel inside edge, repair needed 60'x6'. 2012 Why repair? We are not able to stitch this wide crack and have it hold plus with all the asphalt patching in the crack – this is an indicator that it needs to be removed and repaired.



#29 US-73 (9.0-8.21) looking south at several joint repairs needed in both lanes. Why repair? These are larger patched areas that will need to be repaired – especially if to remain exposed concrete. If to be AC overlaid – some of the smaller areas adjacent to the larger patches could be omitted from the repair listing. If to be concrete surface milled most repair areas could be omitted...



#30 I-80 (371.03 to 372.0) Sta. 983+62 Looking north in the EB passing lane at a 4'x 12' joint repair with alkali gel, discolored, and delaminated. 2010 – Question from the field was 'Why leave some of the stained areas on the edge associated with this repair?' Answers 1. To be overlaid & 2. When we sound the pavement we determine the limits – staining doesn't always mean delamination.



#31 I-80 EB (205.61 to 206.0) Looking west in the driving lane at ASR staining at the joints and retrofits. Note that this 'look' is typical for advanced ASR pavement areas in this project. 2014 – Shows typical ASR staining at the dowel bar retrofits and the outside shoulder at the transverse joints. Have to sound all the areas to determine which can stay and which will be repaired.



#32 US-6 Looking north at the EB at a typical area with indications of a repair, many areas similar. Will not be taking this area due to depth of AC (7.25" average) and due to the large cost if we listed all these areas. Was hard to let these go unrepaired but ... 2009 – These areas were not sunk or raised – only indication was the 'scallop' cracks (yellow arrows). Scallop cracks cannot be the only indicator – has to have a secondary indicator such as sunk, raised, milled down, or fines pumping. This section is still performing well. forces crack sealed in February 2018 – Schedule for a Mill & Fill in 2023 (CN performing 08/25/2020)

Just because it looks like a dog pile – is it really a dog pile?
Know the indicators to make the right decision to repair or not repair...



#33 US-6 (160.0 to 161.0) Looking south at AC scoured in the wheel tracks and transverse joints. AC looks like soil in the scoured areas, very brittle. Many areas similar EB and WB. No repairs – definite AC problem! 2009 – Just because it looks like a needed repair area is it really an underlying concrete problem? I see it as: Asphalt is called flexible pavement and it flexes, loading can cause rutting then the oil eventually leaches out and it becomes dry and brittle, it starts scouring (eating itself away). The concrete base is not usually affected by the asphalt degrading unless it not sealed and water infiltrates



#34 US-6 (164.0 to 165.0) Looking south at AC shoving from the WB outside edge into the WB outside shoulder, inside edge. 2"+ (to 4") high lumpy AC makes for a rough ride. 2009 – Just because it looks like a needed repair area is it really an underlying concrete problem? No repair here – asphalt problem!



#35 I-80 WB RP 347.17 Looking south in the DL IE at a 4'x 5' repair (sunk) and a 4'x 12' repair in the PL that is borderline but looks slightly sunk. 2013 – Interstate 80 – if areas are sunken or raised is indicator of a needed repair to underlying concrete. Note that in the black text I state that the area in the passing lane is borderline repair and the area looks slightly sunk. This indicates the repair area could go either way – no repair or to repair – but taking based on visual cues...



#36 I-80 WB RP 346.91 Looking south at a 4'x 5' repair in the DL OE at a hole with area sunk. 2013 – Interstate 80 – if areas are sunken or raised is indicator of a needed repair to underlying concrete.

Pavement repair examples from past projects 02-23-2020



#37 I-80 EB RP 350.89 Looking northwest at a 12'x 12' repair in the driving lane. Looks like a broken existing repair under the surface of the AC with large AC patches. 2013 – Interstate 80 – Failed existing repair area (orange lines) under asphalt. Red lines = Listed repair area. Lines are approximate...

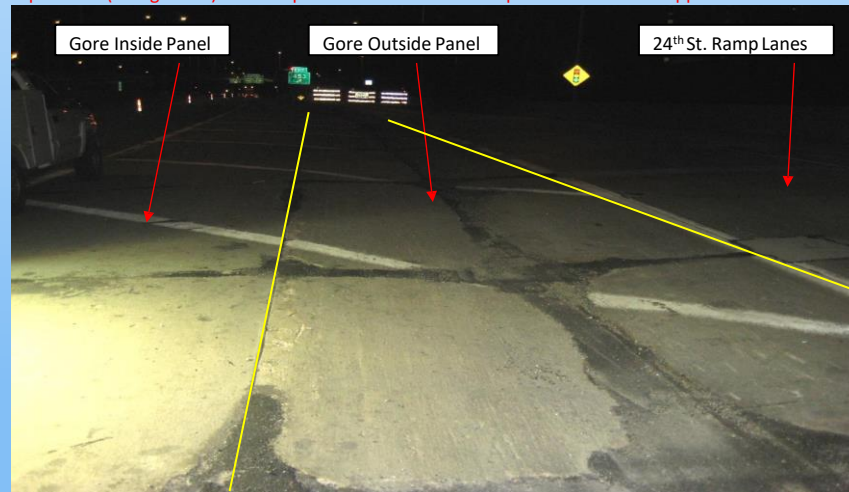

#38 I-80 24th St Interchange RP 453.30 Looking east in the gore between mainline & 24th St. Ramp Lanes at removing the outside panel of the gore and joint repairs to the inside panel of the gore. April 2011 – Removals in the gore area between mainline and 24th St ramp lanes. Note the mastic applied to large areas at the joint lines. Note that 24th St ramp lane is closed. Area to receive an overlay....



#39 US-75 NB Looking east in the NB Lane #1 at a 6'x 12' repair that includes the delaminated existing repair. Note the staining and spalls... 2011 – Painted repair in Lane 1 with failed repair and adjacent staining and delamination. Odd repair mix...

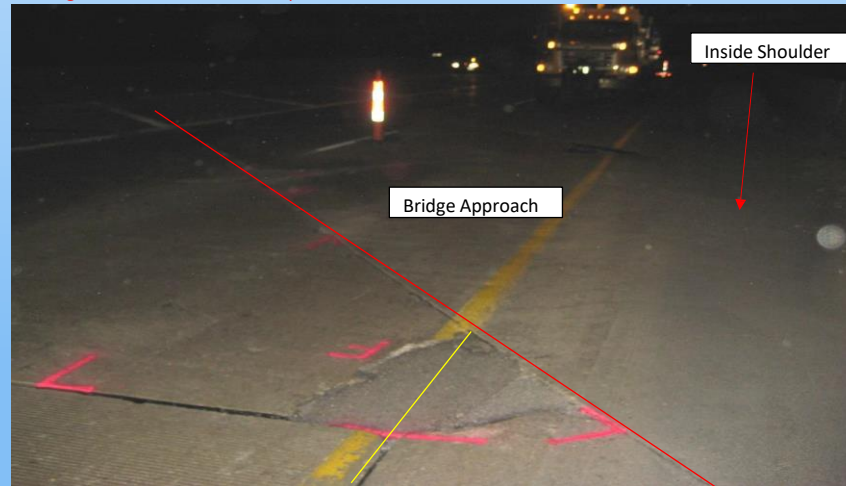

#40 I-80 EB Looking west in the EB inside shoulder, outside edge & lane 1 inside edge at a 8'x 6' repair on a skew adjacent to approach slab of the Bridge. 2011 – Painted repair in Lane 1 and 2' into the inside shoulder – repair on a skew adjacent to bridge approach slab (red line). The paint lines do not follow the spec book (repair extended into separate lane) – should be painted as 2 areas (yellow line).



#41 I-80 WB Rest Area Looking east in the truck lanes at a 23'x 11' repair in the outside panel (note the green outline of the repair area) with multiple cracks, spalling, and delamination. 2009 – I-80 Goehner WB rest area – Large repair area in the 'thru' truck lane (parking on right in photo) this area is now closed off with tall delineators – All parking (trucks only) is to the north as of 2020. See photo #42 for completed repair.



#42 2014 – I-80 Goehner WB rest area – Completed repair area in the 'thru' truck lane (parking on right in photo) this area is now closed off with tall delineators. All parking (trucks only) is to the north as of 2020. See photo #41 for painted repair area. In 2020 repair is still doing well since the access is closed.



#43 I-80 WB Rest Area Sta. 17+18 Looking east in the truck lane, outside panel at not repairing longitudinal crack, is slightly faulted but does not have delamination or spalling. 2009 – I-80 Goehner WB rest area – Long longitudinal crack in the ‘thru’ truck lane’ – no repair in this area and hasn’t changed much in 10 years. Still looked good on the 2019 Repair survey. See Picture #44 for 2014 view of the area.



#44 2014 – I-80 Goehner WB rest area – Long longitudinal crack in the ‘thru’ truck lane’ – still hanging tough after 10 years –due to old RCP with the wire mesh – mesh still holding concrete together.



#45 I-680, I-80 to Fort St. Many areas like this delaminated and did a 4' x 4' joint repair. (ZIP days - 6"x 3" to 4" wide area and doing a 4'x4' joint repair? Seems over excessive!) Partial depth repairs in D2 are forbidden! I would leave this to be sealed – rather than take a chance on a PR repair. This area is a doweled concrete pavement section...



#46 I-680, I-80 to Fort St. Many small spalled and delaminated areas 6"x 3" to 4" wide, doing 4' x 4' joint repairs. (ZIP days - 6"x 3" to 4" wide area and doing a 4'x4' joint repair? Seems over excessive!) I would leave this to be sealed.... This area is a doweled concrete pavement section.