

WELCOME!

**US-81 To Belden
Public Information Meeting**

Please Sign In

Urban Phased Construction

US-81 To Belden

NH-20-5(112); C.N. 31677

NEW AND RECONSTRUCTION URBAN
MM 377.15 - MM 378.00

Temporary traffic signal to
maintain one lane of traffic.

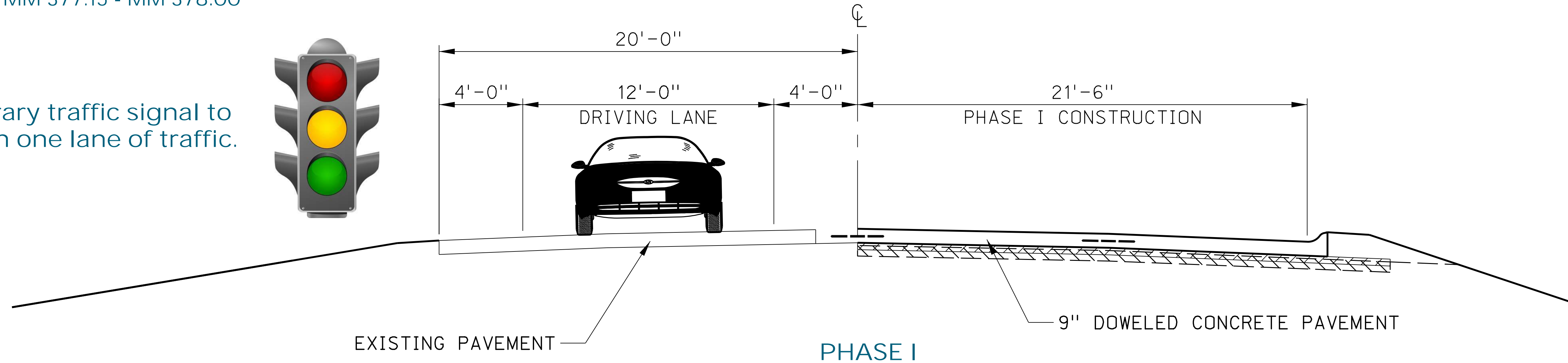

PHASE I

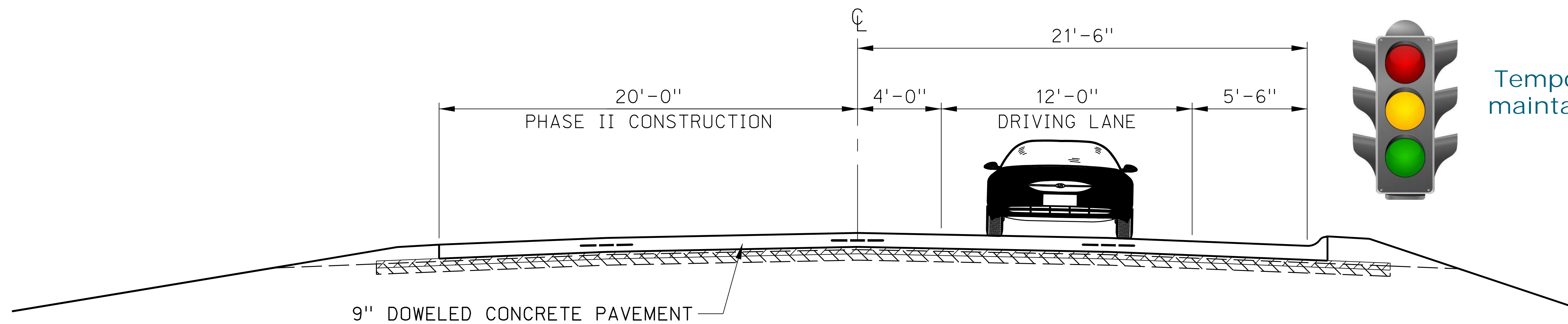

PHASE II

Temporary traffic signal to
maintain one lane of traffic.

PRELIMINARY PLAN
NOT FINAL - SUBJECT TO CHANGE

Typical Cross Sections

US-81 To Belden

NH-20-5(112); C.N. 31677

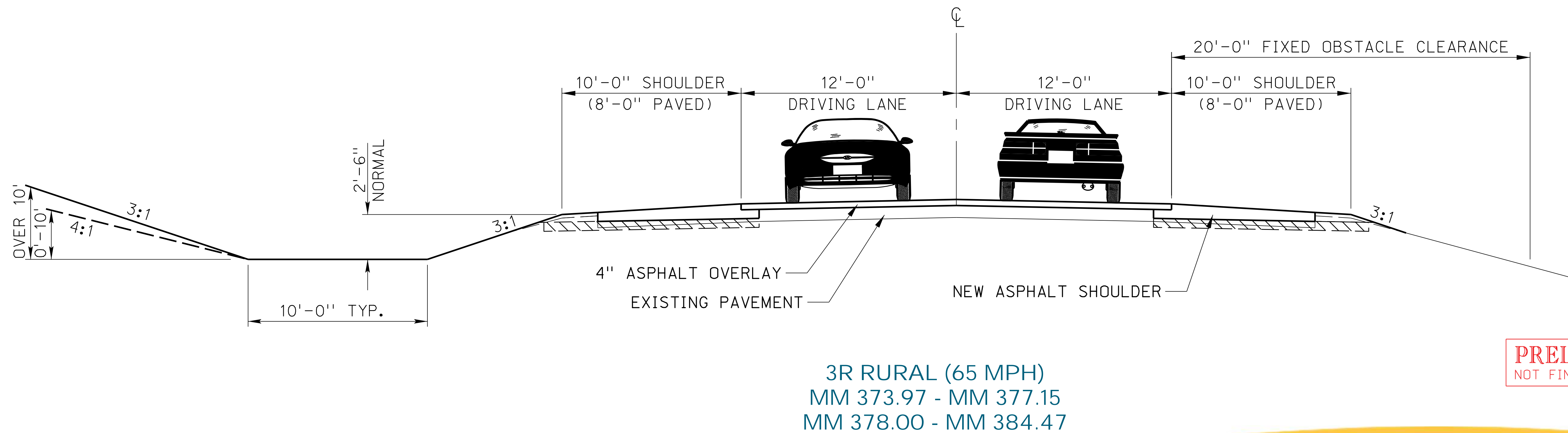
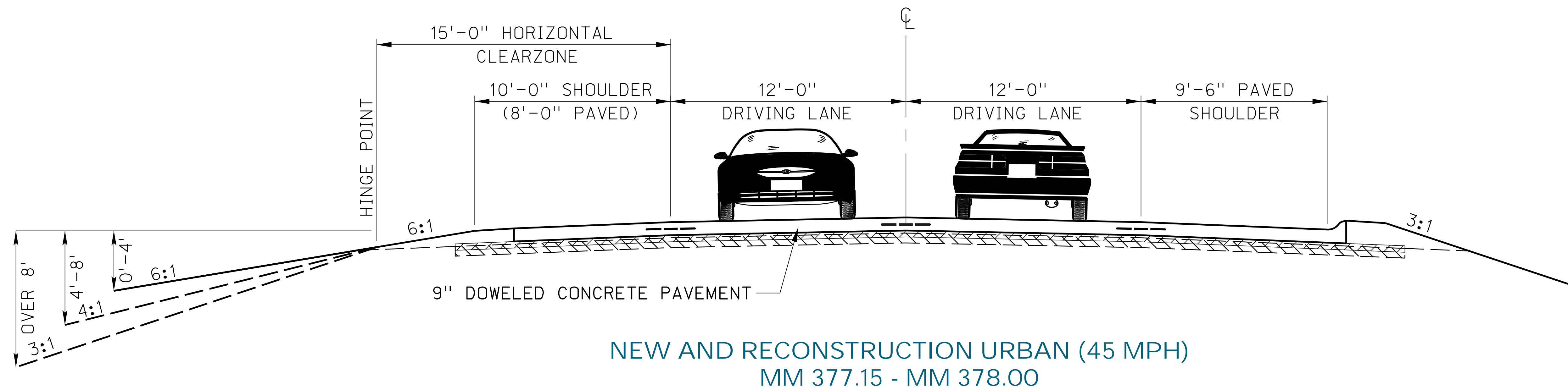

PRELIMINARY PLAN
NOT FINAL - SUBJECT TO CHANGE

Project Timeline

As currently planned, construction could begin as early as spring of 2021 and be completed by fall of 2022







PRELIMINARY PLAN
NOT FINAL - SUBJECT TO CHANGE

Purpose & Need

US-81 To Belden

NH-20-5(112); C.N. 31677

The purpose of the proposed project is to preserve the US-20 transportation asset, improve the reliability of the transportation system, and perpetuate the mobility of the traveling public. The need for the project is based on the deteriorating condition of the existing roadway and bridges.

MAP LEGEND	
	PROJECT RESURFACING
	PROJECT RECONSTRUCTION
	558.5 AVE DETOUR
	W JACKSON ST & 558TH AVE DETOUR

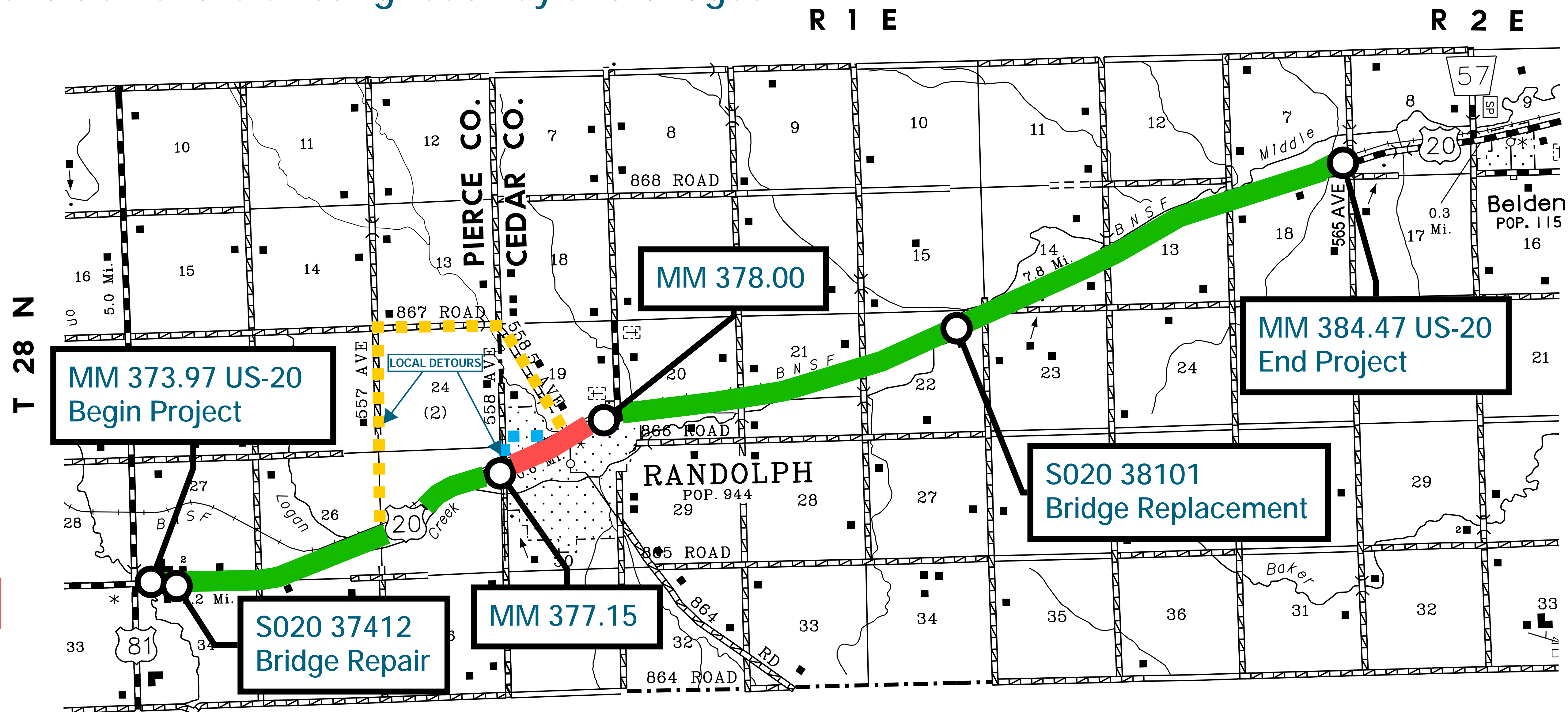

PRELIMINARY PLAN
NOT FINAL - SUBJECT TO CHANGE

Thank you for attending!

US-81 To Belden

Public Information Meeting



US-81 To Belden

Public Information Meeting

