

The information contained in Chapter Sixteen: Pedestrian and Bicycle Facilities, dated May 2022, has been updated to reflect the January 2023 Errata. The errata addresses errors, changes in procedure, changes in NDOT department titles, changes in other Roadway Design Manual chapters and other reference material citations occurring since the latest publication of this chapter.

Chapter Sixteen presents guidance for the design of New and Reconstructed projects; design guidance for 3R projects is provided in Chapter Seventeen.

Chapter Sixteen

Pedestrian and Bicycle Facilities

The Americans with Disabilities Act Title II Regulations ([Americans with Disabilities Act Title II Regulations | ADA.gov](#)), Section 11-8.3000, requires a transition plan when structural modifications are required to provide pedestrian accessibility. The plan will list the physical barriers limiting accessibility, methods for the modification of the barriers, a time frame for achieving compliance with Title II, and the responsible party. **NDOT's** transition plan is found at [Transition Plan \(nebraska.gov\)](#).

In accordance with 28 C.F.R §35.150(d)(2) ([eCFR :: 28 CFR 35.150 -- Existing facilities.](#)), **NDOT** has a duty to include within this plan an evaluation of the location where pedestrian walks cross curbs on its highways. The federal rule states: If a public entity has responsibility or authority over streets, roads, or walkways, its transition plan shall include a schedule for providing curb ramps or other sloped areas where pedestrian walks cross curbs, giving priority to walkways serving entities covered by the Act, including State and local government offices and facilities, transportation, places of public accommodation, and employers, followed by walkways serving other areas.

1. RESOURCE PUBLICATIONS

Pedestrians:

The **Nebraska Department of Transportation (NDOT)** will follow the guidance found in the Proposed Guidelines for Pedestrian Facilities in the Public Right-of-Way (With 2013 Supplement) (Proposed Guidelines (2013)) (Ref. 16.1), issued by the Architectural and Transportation Barriers Compliance Board (<http://www.access-board.gov/guidelines-and-standards/streets-sidewalks/public-rights-of-way/proposed-rights-of-way-guidelines>). Pedestrian facilities may follow local ordinances, at the **Assistant Design Engineer's (ADE's)** discretion, if they meet or exceed **NDOT** requirements.

Proposed Guidelines (2013) (Ref. 16.1) requirements which the **Roadway Design Engineer** determines are technically infeasible on a project shall be documented in the project's correspondence file with the **Roadway Design Engineer's** signature. The documentation must clearly demonstrate why it is technically infeasible to fully comply with the requirements and that the requirements have been met to the maximum extent practicable. For additional information see the **NDOT** Operating Instruction 60-10, "ADA Accessibility Requirements in Transportation Projects" (Appendix B, "Selected NDOT Operating Instructions").

Bicycles/ Shared Use Paths:

For further guidance beyond what is found in this manual the designer should refer to the **American Association of State Highway and Transportation Officials (AASHTO's) Guide for the Development of Bicycle Facilities** (Ref. 16.2).

Roundabouts:

Requirements for pedestrian and bicycle access at a roundabout may be found in the *Proposed Guidelines (2013)* (Ref. 16.1). For further guidance the designer should refer to NCHRP Report 672, "Roundabouts: An Informational Guide", Second Edition (Ref. 16.3) (http://onlinepubs.trb.org/onlinepubs/nchrp/nchrp_rpt_672.pdf).

2. DEFINITIONS

ACCESSIBLE ROUTE – A continuous and unobstructed pedestrian circulation path in the public right-of-way, the various components of which comply with the guidance found in the *Proposed Guidelines (2013)* (Ref. 16.1).

ADA - The Americans with Disabilities Act of 1990 (<http://www.ada.gov/>), which provides comprehensive civil rights protection to individuals with disabilities in the areas of employment, transportation, public accommodations, state and local government services, and telecommunications.

ALTERATION - Defined by the *Proposed Guidelines (2013)* (Ref. 16.1) as "A change to a facility in the public right-of-way that affects or could affect pedestrian access, circulation, or use. Alterations include, but are not limited to, resurfacing, rehabilitation, reconstruction, historic restoration, or changes or rearrangement of structural parts or elements of a facility."

BICYCLE FACILITIES – Defined by the Manual on Uniform Traffic Control Devices for Streets and Highways (MUTCD) as "A general term denoting improvements and provisions that accommodate or encourage bicycling, including parking and storage facilities, and shared roadways not specifically defined for bicycle use."

BICYCLE LANE - Defined by *MUTCD* as "A portion of a roadway that has been designated for preferential or exclusive use by bicyclists by pavement markings and, if used, signs."

BIKEWAY – Defined by *MUTCD* as "A generic term for any road, street, path or way that in some manner is specifically designated for bicycle travel, regardless of whether such facilities are designated for the exclusive use of bicycles or are to be shared with other transportation modes."

BLENDED TRANSITION – Defined by the *Proposed Guidelines (2013)* (Ref. 16.1) as "A raised pedestrian street crossing, depressed corner, or similar connection between the pedestrian access route at the level of the sidewalk and the level of the pedestrian street crossing that has a grade of 5 percent or less."

CROSS SLOPE – Defined by the *Proposed Guidelines (2013)* (Ref. 16.1) as "The grade that is perpendicular to the direction of pedestrian travel."

CROSSWALK - The Nebraska Revised Statutes, Chapter 60 Motor Vehicles defines a crosswalk as:

1. "That part of a roadway at an intersection included within the connections of the lateral lines of the sidewalks on opposite sides of such roadway measured from the curbs or, in the absence of curbs, from the edge of the roadway; or
2. Any portion of a roadway at an intersection or elsewhere distinctly designated by competent authority and marked for pedestrian crossing by lines, signs, or other devices."

CURB RAMP - A connection between the pedestrian access route at the level of the sidewalk and the level of the pedestrian street crossing that has a grade which is between 5 percent and 8.3 percent inclusive in the direction of pedestrian travel. Curb ramps can be perpendicular or parallel, or a combination of parallel and perpendicular ramps.

PEDESTRIAN – Defined by *MUTCD* as "A person on foot, in a wheelchair, on skates, or on a skateboard."

PEDESTRIAN CROSSING – A pedestrian crossing facilitates the movement of the non-motorized public (e.g. pedestrians, bicyclists) across highways, railroad tracks, and rivers or streams.

PEDESTRIAN RAMP – A part of an accessible route that has a running slope which is between 5 percent and 8.3 percent inclusive in the direction of pedestrian travel.

PUBLIC RIGHT-OF-WAY - Defined by the *Proposed Guidelines (2013)* (Ref. 16.1) as "Public land or property, usually in interconnected corridors, that is acquired for or dedicated to transportation purposes.

RUNNING SLOPE - Defined by the *Proposed Guidelines (2013)* (Ref. 16.1) as "The grade that is parallel to the direction of pedestrian travel."

SHARED ROADWAY - Defined by *MUTCD* as "A roadway that is officially designated and marked as a bicycle route, but which is open to motor vehicle travel and upon which no bicycle lane is designated."

SHARED USE PATH - Defined by *MUTCD* as "A bikeway outside the traveled way and physically separated from motorized vehicular traffic by an open space or barrier and either within the highway right-of-way or within an independent alignment. Shared-use paths are also used by pedestrians (including skaters, users of manual and motorized wheelchairs, and joggers) and other authorized motorized and non-motorized users."

SIDEWALK – Defined by *MUTCD* as "That portion of a street between the curb line, or the lateral line of a roadway, and the adjacent property line or on easements of private property that is paved and intended for use by pedestrians."

TECHNICALLY INFEASIBLE – Defined by the Department of Justice in the 2010 ADA Standards for Accessible Design as "...or because other existing physical or *site* constraints prohibit modification or *addition* of *elements, spaces*, or features that are in full and strict compliance with the minimum requirements." (emphasis original to DOJ) A finding of "technically infeasible" still requires that the element of the pedestrian path in question be built to the minimum applicable standards to the maximum extent possible.

3. BIKEWAYS AND SHARED USE PATHS

By statute, the **State of Nebraska** does not allow bicycles and pedestrians on the Interstate System or on freeways, see the Reissue Revised Statutes of Nebraska 60-6,142 (<https://nebraskalegislature.gov/laws/statutes.php?statute=60-6,142>) and 60-6,144 (<https://nebraskalegislature.gov/laws/statutes.php?statute=60-6,144>). The **State of Nebraska** does permit bicycles on other roadways and roadway shoulders.

In some cases, the scope of work of a highway improvement project may include construction of separate bicycle or pedestrian facilities. In many instances design features of separate bicycle facilities are controlled by the adjoining roadway and are an element of the design of the roadway itself. For further information on bicycle facilities, see the Guide for Development of Bicycle Facilities (Ref. 16.2).

SIDEWALK & SHARED USE PATH MINIMUM WIDTHS		
	ON ROW	ON BRIDGES
* SIDEWALK	Four feet, providing five foot by five foot passing spaces every 200 feet (NDOT prefers a continuous five foot width).	Four feet, providing five foot by five foot passing spaces every 200 feet (NDOT prefers a continuous five foot width).
** SHARED USE PATH	Ten feet Shared use path widths of 11 feet to 14 feet should be used where pedestrian use is $\geq 30\%$ of the total pathway volume and there are 300 total pathway users in the peak hour.	*** Ten feet

* *Proposed Guidelines (2013)* (Ref. 16.1)

** Guide for the Development of Bicycle Facilities (Ref. 16.2)

*** Bridge Office Policies and Procedures (Ref. 16.6)

NOTE: Designers should check municipal ordinances in regard to sidewalk and bikeway width requirements. This check is for information; **NDOT** is not required to design to local ordinances; however, **NDOT** may design to the local ordinance as long as it meets minimum guidance and the additional work is accomplished at the municipality's cost.

Exhibit 16.1 Sidewalk and Shared Use Path Minimum Widths

4. SIDEWALKS

The need for sidewalk should be considered during the preliminary design of a project. The final determination regarding the need to include sidewalk in a project will be made at the plan-in-hand inspection, giving consideration to the input of the local governing authority and public. Items to consider in determining the need for sidewalk to be included in the project include:

- When sidewalk currently exists along a roadway, non-compliant sidewalk should be brought into compliance.
- Build new sidewalk only as required to match into the existing sidewalk in 15 feet or less of length unless this results in a grade greater than 15%. **ADE** approval is required to exceed a length of 15 feet and/ or a grade greater than 15%.
- Areas which are accessible prior to the project should remain accessible at the conclusion of the project, unless technically infeasible.
- If an existing bridge structure with a sidewalk is to be rehabilitated or replaced, sidewalk will typically be retained or included on the new structure.
- When provided, new sidewalk should connect the origins and destinations of existing pedestrian trips within the project limits, e.g. residential development and schools.

4.A Sidewalk Design Considerations

Widths - Sidewalk widths may vary; the minimum width is four feet, however, **NDOT** prefers a continuous width of five feet. For sidewalks less than five feet in width a passing area shall be provided at intervals of 200 feet or less. The passing area shall be a minimum of five feet by five feet. See [EXHIBIT 16.1](#) for additional information.

Cross Slope - The maximum allowable cross slope is 2%, except as noted elsewhere herein. **NDOT** prefers a cross slope of 1.5% to allow for construction tolerance.

Running Slope (Grade) – Where the sidewalk is contained within the right-of-way, its grade shall not exceed the general grade established for the adjacent street or highway. When the sidewalk profile is independent of the roadway alignment, the maximum allowable sidewalk grade is 5%; if the grade of the sidewalk exceeds 5% a pedestrian ramp will be required.

Buffer Areas - Generally, based on the available right-of-way, a five foot wide buffer area between the back of curb and the edge of sidewalk is the preferred section ([EXHIBIT 16.2](#) illustrates the typical sidewalk section). Where right-of-way is limited a minimum buffer width of two feet should be provided to allow adequate space for hydrants, parking meters, and other roadside appurtenances. If no buffer is provided, a sidewalk width of six feet is provided to accommodate both these appurtenances and a minimum continuous four foot width for an access path.

Protruding Objects – No object will be allowed to protrude more than four inches into the pedestrian circulation path between a height of two feet three inches and six feet eight inches above the sidewalk surface.

Curb Ramps - See Section 7 of this chapter.

Fencing – When a sidewalk is adjacent to a steep slope (steeper than 1:3) which is sloping away from the sidewalk, is over six feet in depth, and where no handrail or barrier is present a chain link fence should be installed, typically one foot from the sidewalk (See EXHIBIT 16.3). The fence should have a minimum height of four feet with the chain link fabric facing the sidewalk. If the sidewalk and the steep slope are on the approach to a viaduct or overpass, the concrete bridge railing should be extended onto the approach slab and, where possible, the sidewalk flared away from the traffic.

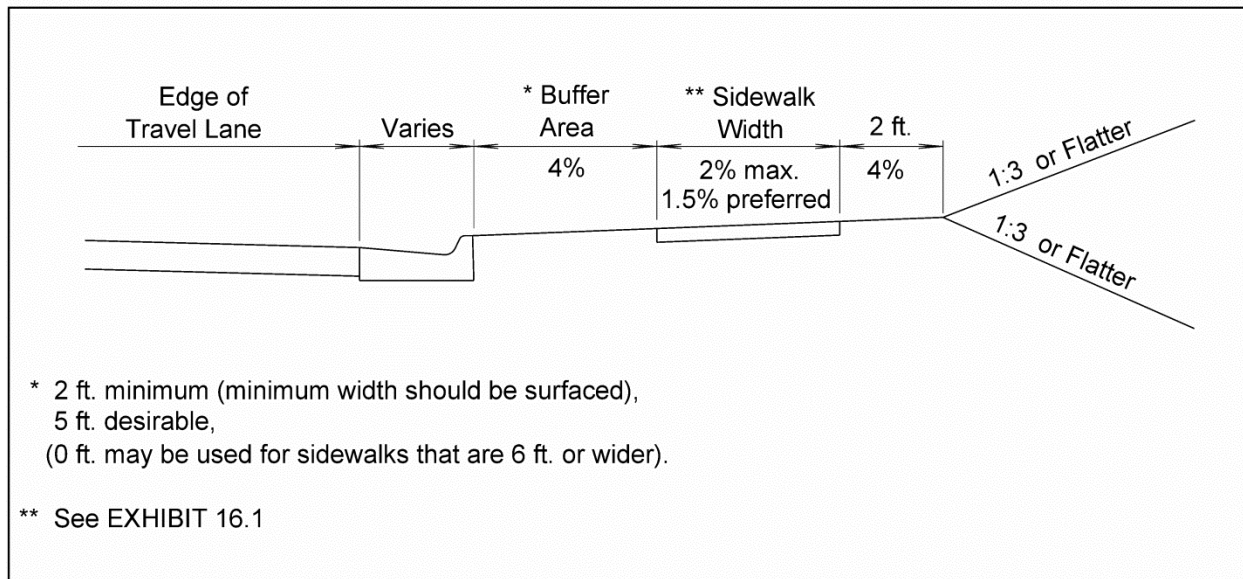

Exhibit 16.2 Typical Sidewalk Section

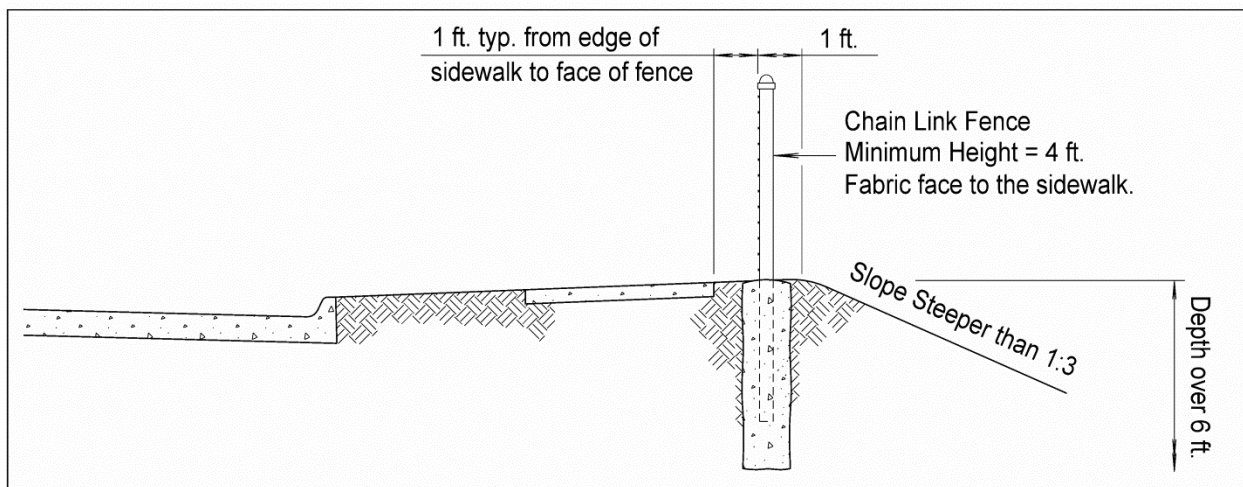

Exhibit 16.3 Fencing on Steep Slopes Adjacent to a Sidewalk

5. PEDESTRIAN UNDERPASSES

The minimum width of an underpass should be the clear width of the approaching sidewalk/ shared use path; the desirable width is the sidewalk/ shared use path width plus two feet clearance on each side. The minimum vertical clearance should be ten feet. For underpasses over 60 feet in length both dimensions may be increased. Sight lines should be unobstructed, providing a clear view of the open ends of the tunnel. The designer will address the concerns of the underpass users (including location and ventilation) and the drainage of the facility when designing the underpass. Lighting of the underpass will be coordinated with the **Roadway Design Lighting Unit**.

6. PEDESTRIAN CROSSINGS

Warrant analysis for mid-block pedestrian street crossings, pedestrian crossings at railroad tracks, and for pedestrian structures (overpasses and underpasses) is the responsibility of the **Traffic Engineering Division (Traffic Engineering)** and will be developed during the plan-in-hand or public meeting processes. The roadway designer will coordinate the design of the pedestrian crossing with the design of the highway, sidewalk/ bikeway, railroad crossing, and/ or bridge.

The design guidance for a pedestrian crossing includes:

- A pedestrian street crossing (hereafter referred to as a crosswalk) will connect departure and arrival sidewalks.
- Crosswalks shall continue through medians. The designer will verify that raised medians in the urban section of a project adhere to the *Proposed Guidelines (2013)* (Ref. 16.1), providing pedestrian access across the street from curb ramp to curb ramp.
- On wide, divided roadways, **Traffic Engineering** may require a pedestrian refuge area in the median. A pedestrian refuge is an area a minimum of six feet wide in the direction of pedestrian travel that allows a pedestrian to stop and wait for traffic mid-crossing.
- Marked crosswalks shall be a minimum six feet wide.
- The maximum running slope in the direction of pedestrian travel shall be 5%.
- The maximum cross-slope at a yield or stop sign controlled crosswalk shall be 2%.
- The maximum cross-slope at a crosswalk that is not yield or stop sign controlled is 5%.
- The cross-slope of a mid-block crosswalk is permitted to match the street grade.
- Where a pedestrian structure is required, the **Bridge Division (Bridge)** is responsible for the design of the structure.
- Accessible pedestrian signals are optional devices that provide non-visual guidance for those with visual disabilities. They are not routinely installed on signal projects but can be installed upon request for, and the completion of, an engineering study that determines if they are needed for the project. The designer will coordinate the provision of accessible pedestrian signals at crosswalks with **Traffic Engineering**; for further information see Chapter Fourteen: [Traffic](#), Section 4.A.

7. CURB RAMPS

Curb ramps compliant with the *Proposed Guidelines (2013)* (Ref. 16.1) **are required:**

- At crosswalks (marked or unmarked)
- At an intersection having curb or other barriers to entry from a walkway
- Where accessible on-street parking is provided

Curb ramps **shall be** constructed or reconstructed on any New, Reconstructed, or 3R project where surfacing of any thickness, with or without milling, is placed on a crosswalk, whether the crosswalk is on the project mainline, on a side street, or at a signalized driveway or alley. Curb ramps are not required if the new surfacing does not extend to the crosswalk. Curb ramps may be built on any project, including Preventive Maintenance, with the concurrence of the **District Engineer (DE)** and the **Roadway Design Engineer**.

Curb ramps will be built using the curb ramp plan (See the Standard/Special Plans Book (Standard Plans), Ref. 16.4) <http://www.roads.nebraska.gov/business-center/design-consultant/stand-spec-manual/>).

Design guidance for curb ramps includes, but is not limited to:

- A curb ramp is a transition from the pedestrian access route to the pedestrian street crossing with a grade which is between 5% and 8.3% inclusive in the direction of pedestrian travel (the roadway designer is advised to design curb ramps to an 8% maximum slope whenever possible to allow for construction tolerance).
- A blended transition connects a pedestrian access route and a pedestrian street crossing with a grade of less than 5% in the direction of pedestrian travel. A blended transition will hereafter be referred to as a curb ramp and will be built using the curb ramp plan (See the *Standard Plans*, Ref. 16.4).
- The desirable orientation of a curb ramp is perpendicular to the direction of crossing vehicular traffic. A diagonal orientation should only be used when physical constraints preclude the use of a perpendicular ramp.
- When tying a curb ramp to existing sidewalk, build new sidewalk only as required to match into the existing sidewalk in 15 feet or less of length unless this results in a grade greater than 15%. **ADE** approval is required to exceed a length of 15 feet and/ or a grade greater than 15%.
- On reconstruction projects, the *Proposed Guidelines (2013)* allows a transitional segment of sidewalk to match the cross slope of the existing sidewalk; this transition does not require technically infeasible documentation to the project file.
- Curb ramps should be the width of the sidewalk and shall be a minimum of four feet wide (exclusive of flared sides). Curb ramps on shared use paths will be the full width of the path.
- The maximum allowable ramp cross slope (perpendicular to the direction of pedestrian travel) is 2%; the preferred cross slope is 1.5%.
- Curb ramp length shall not exceed 15 feet.
- Where a side of a perpendicular curb ramp abuts a public sidewalk, the sides of the ramp shall be flared with a maximum 10% slope.
- A four foot by four foot minimum turning space will be provided at either the top of a perpendicular curb ramp or at the bottom of a parallel curb ramp. The turning space will

have a 2% maximum slope in any direction (**NDOT** prefers a slope of 1.5%). A five foot diameter for wheel chair foot rest swing is required if the turning space is adjacent to a vertical obstruction.

- The surface of a curb ramp shall be stable, firm, and slip-resistant.
- Gratings and similar access covers shall not be located on curb ramps or turning spaces.
- A detectable warning area for the visually impaired consisting of truncated domes shall be provided at each pedestrian curb ramp located at intersections, crosswalks, islands that are six feet in width or greater, and at signalized drives and alleys where a vehicle is not intended to stop.
- The detectable warning panels shall contrast visually with the adjacent gutter, street, or sidewalk (either darker or lighter).
- Detectable warning panels will typically be cast-in-place when built with a new curb ramp.
- When a surface applied detectable warning panel is used on an existing curb ramp, the bid pay item is “Detectable Warning Panel”.
- Transitions shall be free of abrupt changes:
 1. If the project changes the grade at the gutterline of an existing roadway through a crosswalk with existing curb ramps by one-quarter inch or less, no adjustment is required.
 2. If the project changes the grade at the gutterline of an existing roadway through a crosswalk with existing curb ramps by one-quarter inch to one-half inch, the grade change should be beveled at a maximum 1:2 ratio.
 3. If the project changes the grade of the existing roadway at the gutterline through a crosswalk with existing curb ramps by more than one-half inch, either match the grade at the gutterline through the crosswalk or reconstruct the curb ramp to current standards.
- Counter slopes of adjoining gutters and road surfaces connecting to the full width of a curb ramp shall be a maximum of 5%, measured along the direction of pedestrian travel (See [EXHIBIT 16.4](#)).
- Grade breaks must be perpendicular to the direction of pedestrian travel.
- Surface slopes that meet at grade breaks shall be flush.
- Pavement drainage is a particular concern at curb ramps. Consideration will be given to the locations of inlets and sidewalks or crosswalks to verify that there is sufficient room for the five foot blockout width required for a curb inlet and that neither grates nor ponded water are impediments to pedestrian travel (See the [Drainage Design and Erosion Control Manual \(Drainage Manual\)](#), Ref. 16.5, Chapter One: [Drainage](#), Section 10.B.1) (<http://www.roads.nebraska.gov/business-center/design-consultant/rd-manuals/>)
- Curb ramps may be constructed to meet local ordinances if those requirements meet or exceed **NDOT** requirements. Additional project costs associated with local ordinances will normally be the responsibility of the Municipality.
- Exemptions to the above requirements for curb ramps may be granted if:
 1. The curb ramp has been constructed to the standards to the maximum extent practicable,
 2. It is “technically infeasible” to construct a curb ramp which meets all of the standards, **and**
 3. There is an accessible alternate route approved by the municipality (a Municipal agreement will be required).

- An exemption to the construction of a curb ramp requires the **Roadway Design Engineer's** written approval in the project file. This exemption letter will document that the curb ramp was constructed to the maximum extent practicable, which aspects of the curb ramp were not built to the standards, and why it is technically infeasible to meet all of the requirements of the *Proposed Guidelines (2013)* (Ref. 16.1).
- When there are no pedestrian facilities crossing the project, the designer **must** document this fact in the plan-in-hand report or in a decision document saved in the project file as the reason why curb ramps were not provided with the project.

Design details for curb ramps may vary according to many factors, including:

- Intersection radius
- Angle of street intersections
- Location of obstacles (e.g. fire hydrants, signs, and signal control devices)
- Possible sight obstructions
- Suitable location for stop bar

For additional information see the Nebraska Department of Transportation Operating Instruction 60-10, "ADA Accessibility Requirements in Transportation Projects" (Appendix B, "Selected NDOT Operating Instructions").

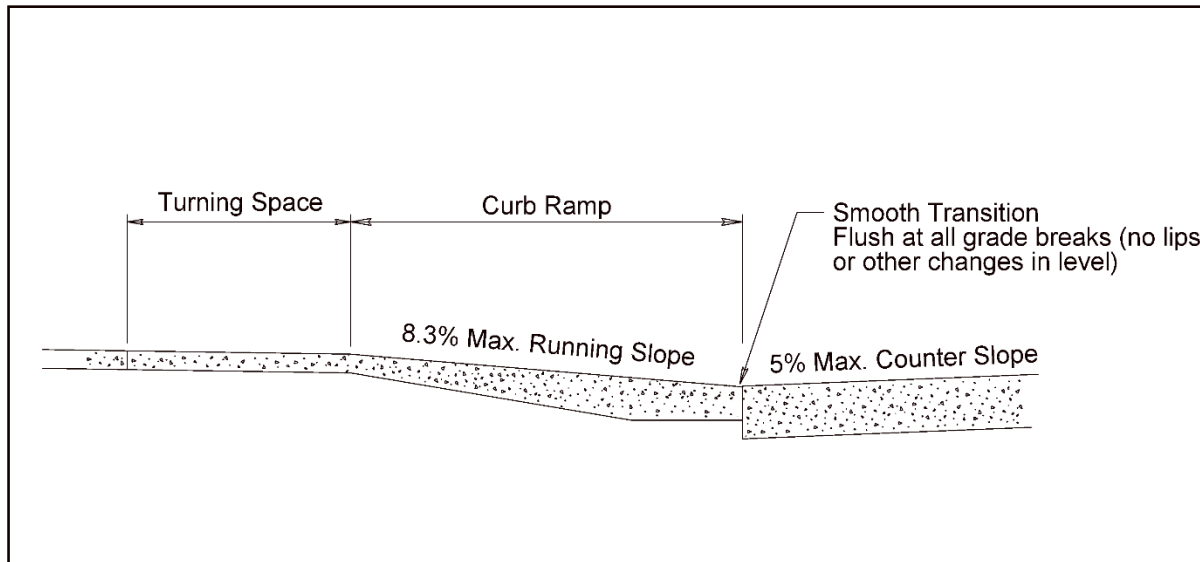

Exhibit 16.4 Curb Ramp Counter Slopes

8. ACCESSIBLE ON-STREET PARKING

See Chapter Ten: Miscellaneous Design Issues, Section 13.A.

9. PEDESTRIAN RAMPS

A part of an accessible pedestrian route that has a slope which is between 5% minimum and 8.3% maximum in the direction of travel will be considered a pedestrian ramp and shall comply with the *Proposed Guidelines (2013)* (Ref. 16.1) requirements, including:

- The maximum allowable slope of a pedestrian ramp in new construction shall be 8.3% in the direction of travel (with a desirable maximum slope of 8%).
- The maximum allowable cross slope shall be no greater than 2% (**NDOT** preferred cross slope is 1.5%).
- The maximum allowable rise for a length of run shall be 30 inches.
- Pedestrian ramps shall have a minimum clear width of four feet and shall have landings at the top and bottom of each ramp.
- The maximum allowable cross slope of a landing is 2% in any direction (**NDOT** prefers a cross slope of 1.5%).
- Landings shall be at least as wide as the pedestrian ramp and the length of the landing shall be at least five feet. If the pedestrian ramp changes direction at the landing, the landing shall have a minimum size of five feet by five feet.
- Pedestrian ramps which have a rise of more than six inches or are six feet or greater in length shall have handrails on both sides of the ramp (curb ramps are not required to have handrails).
- The surface of the pedestrian ramp run and landing shall extend a minimum of 12 inches beyond the inside face of the handrail (See EXHIBIT 16.5).
- Pedestrian ramps and their approaches will be designed so that water will not pond on walking surfaces.
- The surface of the pedestrian access route shall be firm, stable, and slip resistant.

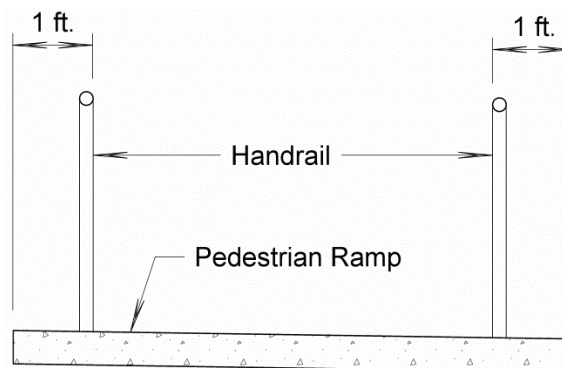

Exhibit 16.5 Typical Section of a Pedestrian Ramp
(Adapted from the *Proposed Guidelines (2013)*, Ref. 16.1)

10. STEPS AND STAIRS

Exterior stairs which connect levels that are not connected by an elevator, ramp, or other accessible means of vertical access must comply with the following *Proposed Guidelines (2013)* (Ref. 16.1) guidelines:

- Steps on a flight of stairs shall have uniform riser heights of between four inches and seven inches and uniform tread widths of not less than 11 inches as measured from riser to riser.
- Stairway treads shall include a minimum two-inch wide strip which contrasts visually with the tread and riser. The strip shall be located at the front of and shall run the full width of the tread.
- The undersides of nosings shall not be abrupt. The radius of curvature at the leading edge of the tread shall be no greater than one-half inch.
- Risers shall be sloped or the underside of the nosing shall have a maximum angle of 30° from the vertical. Nosings shall project not more than one and one-half inches.
- Stairways shall have handrails on both sides of the stairs (See Section 11 of this chapter).
- Exterior stairs and their approaches shall be designed so that water will not pond on the walking surface.

The **Special Projects Unit** in **Bridge** will provide site-specific plans upon request from the roadway designer.

11. HANDRAILS FOR PEDESTRIAN RAMPS AND STAIRS

Handrails shall comply with the *Proposed Guidelines (2013)* (Ref. 16.1) and will have the following features:

- Where required, handrails shall be provided along both sides of stairs and pedestrian ramp segments. The inside rail shall be continuous.
- If handrails are not continuous, they shall extend at least one foot beyond the top and bottom of the pedestrian ramp segment and the extension shall be parallel to the landing (See EXHIBIT 16.6).
- The minimum clear space between handrails and a vertical surface shall be one and one-half inches.
- Gripping surfaces shall be continuous.
- The top of handrails shall be between 34 and 38 inches vertically above the walking surface, stair nosing, and pedestrian ramp surface. The height of the handrail shall be consistent.
- Ends of handrails shall be rounded or smoothly turned to the wall, floor, or post.
- Handrails shall not rotate within their fittings.

The **Special Projects Unit** in **Bridge** will provide site-specific plans upon request from the roadway designer.

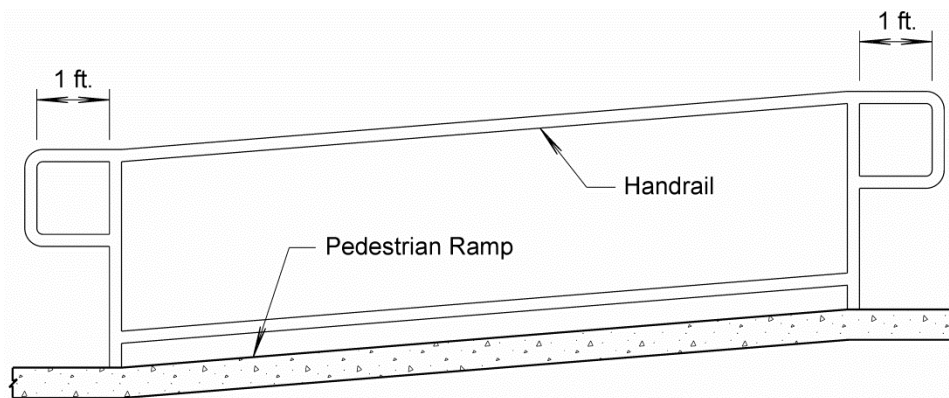

Exhibit 16.6 Typical Handrail Extension at a Pedestrian Ramp
(Adapted from the *Proposed Guidelines (2013)*, Ref. 16.1)

12. PEDESTRIAN ACCESS DURING CONSTRUCTION

When construction obstructs pedestrian access, the roadway designer will consider the need for temporary access measures for pedestrians with disabilities to businesses or other publicly-used facilities during the construction of the project. The designer will also address the needs of disabled individuals crossing the project during construction and the need for implementing temporary measures to meet these needs when identified. Special consideration will be given to schools (when in session), publicly-accessed government offices and medical facilities. The designer will inform **PS&E** of the need to include the Special Provision titled “Pedestrian Access During Construction” on projects where there are pedestrian facilities within the limits of the project.

12.A Pedestrian Access Review

The roadway design process includes an investigation to determine the need for accessibility of the sidewalk, shared use path, and street crossings for disabled individuals during the construction of the project as follows:

Roadway Design (Activity 5300, Clarity Task Code 5350): Prior to the plan-in-hand field inspection the roadway designer will take into account the possible need for disabled individuals to use the sidewalks, shared use paths, and street crossings in and through the project area. The designer will estimate the time of closure for the pedestrian access construction phase of the project, including utilities and other construction items, to assist in:

- Determining the type of temporary access required
- Designing the phasing of the pedestrian access
- The preparation of NEPA documents (if required)

This information will be made available to the public at a public meeting.

The roadway designer will request that the **District** investigate the need for access in and across the project area by pedestrians with disabilities and that the **District** contact public officials, business owners, and others, reporting the findings to **Roadway Design** at the plan in hand inspection. The evaluation of the use of the sidewalks, shared use paths, and street crossings in and through the construction zone by individuals with disabilities should include, but not be limited to:

- Contacting organizations in the community that provide support for persons with disabilities for their input
- An identification of people with disabilities living in, working in, or using the area of the project
- A determination of how, when, and in what way the area of the project is likely to be used by specifically identified persons with disabilities
- Obtaining the recommendations of the local officials regarding which temporary access measures should be considered during the construction of the project

Plan-In-Hand (Activity 5300, Clarity Task Code 5380): The roadway designer and **District** personnel should review commercial or publicly-used buildings along the project where the public access route provides the primary or only public pedestrian access to the building. The **District** should further identify how the project will impact pedestrian access to schools, governmental offices, medical facilities, and other buildings that are likely to generate regular pedestrian traffic on the public sidewalks, shared use paths, and street crossings. **Municipality/ Village** representatives should be invited to attend the plan-in-hand to discuss handicapped accessible routes and known accessibility needs, both when the project is complete and during construction.

Public Meetings: The engineering statement or video for public meetings should address temporary pedestrian access during the construction of the project, e.g. “We are reviewing and will address pedestrian access”, and request information to identify needs for access in or across the project area during construction.

The roadway designer will compile the available information concerning disabled pedestrian access and discuss the need for temporary facilities which are to be constructed as a part of the project with his/ her **Roadway Design Unit Head (Unit Head)** and with the **District**. If there is no identifiable need for special accommodation for access to use the project area during the construction period, special accommodations will not be included with the plans, however a special provision will be added to the project stating that the **District** will be responsible for providing pedestrian access identified during construction.

Design Detail Review (Activity 5500, Clarity Task Code 5576): Before notification that the Roadway Design Detail Plans are available (Clarity Task Code 5550), **District** personnel should meet with local officials, property owners, and local resource agencies for disabled persons to:

- Verify that the information concerning the usage patterns and subsequent needs of disabled pedestrians is current
- Inform the local officials and resource agencies of the proposed temporary pedestrian access facilities and of the tentative project schedule

12.B Example Special Provisions

- The contractor will construct sidewalks in such a way that will minimize the time that pedestrian access to properties along the project is closed.
- The contractor will maintain pedestrian traffic at all times that the business is open or provide an accessible route to be used during the closing of sidewalk at Station _____.
- The contractor may close the sidewalk from Friday to Monday (after normal business hours or when the business is closed).
- The contractor must construct a temporary ADA pedestrian accessible path or access at Station _____.
- The contractor will develop and implement a plan for the phasing of work that involves the obstruction, removal, or construction of sidewalks to minimize the disruption of pedestrian access to adjoining businesses. A plan will be implemented to provide reasonable temporary access during sidewalk construction to a business that uses the public sidewalk for its only or ADA accessible pedestrian access.

13. ADA UPGRADES - COST SHARING

See the Nebraska Dept. of Transportation Operating Instruction 60-11, "Municipal Cost Sharing" (Appendix B, "Selected NDOT Operating Instructions").

14. REFERENCES

- 16.1 Architectural and Transportation Barriers Compliance Board, Proposed Guidelines for Pedestrian Facilities in the Public Right-of-Way (With 2013 Supplement) (Proposed Guidelines (2013)), Washington, D.C., 2013. (<http://www.access-board.gov/guidelines-and-standards/streets-sidewalks/public-rights-of-way/proposed-rights-of-way-guidelines>)
- 16.2 American Association of State Highway and Transportation Officials, Guide for the Development of Bicycle Facilities, Fourth Edition, Washington, D.C., 2012.
- 16.3 Transportation Research Board, "Roundabouts: An Informational Guide – Second Edition", NCHRP Report 672, Washington, DC, 2010. (http://onlinepubs.trb.org/onlinepubs/nchrp/nchrp_rpt_672.pdf)
- 16.4 Nebraska Department of Transportation, Standard/Special Plans Book (Standard Plans), Current Edition. (<http://www.roads.nebraska.gov/business-center/design-consultant/stand-spec-manual/>)
- 16.5 Nebraska Department of Transportation, Drainage Design and Erosion Control Manual (Drainage Manual), Current Edition. (<http://www.roads.nebraska.gov/business-center/design-consultant/rd-manuals/>)
- 16.6 Nebraska Department of Transportation, Bridge Office Policies and Procedures (BOPP), 2013. (<http://www.roads.nebraska.gov/media/2912/bopp-manual.pdf>)
- 16.7 Nebraska Department of Transportation, Design Process Outline (DPO), Current Edition. (<https://dot.nebraska.gov/business-center/design-consultant/>)