

Chapter 13 — Railings

13.1—OVERVIEW

Standard weights for each rail type are provided in Table 3.1 in §3.3.2.

13.1.1—Design Criteria

13.1.1.1—New Construction

13.1.1.1.1—Rail Type

Final rail selection will be determined at data sheet approval, but general guidelines are:

- Use Closed Rail for Grade Separations.
- Use Closed Rail for stream crossings less than 300 ft with hydraulic section approval.
- Use Open Concrete Rail (OCR) all for stream crossings 300 ft. and greater.

13.1.1.1.2—Rail Height

- 42 in. Rails
 - Use 42 in. NU Rail on structures carrying Interstate and expressway traffic.
 - Use 42 in. NU Rail as a minimum over Railroads, see §2.3 for additional information.
 - Use 42 in. NU Rail as a separation barrier for bridges with sidewalks.
- 39 in. Rails
 - Use 39 in. Concrete Rail on all Interstate grade separations and State Highway Structures. The 39 in. Single Slope Closed Rail (SSCR) is preferred.
- 34 in. Rails
 - Use 34 in. NU Rail may be used on allowable Non-System Bridges. Not permitted on curved bridges.

The 300 ft. minimum limit for use of OCR was chosen to capture most of the river crossings in the state. Open Concrete Rails provide operational advantages for snow removal as well as improved deck drainage, particularly on bridges with narrow shoulders. These benefits become more prevalent for longer bridge structures. For longer bridge structures that span both roadways and stream crossings, the Designer should consider using the closed section only where required over recreational trails, sidewalks, vehicle, or railroad traffic.

Existing bridges with open concrete rails in the state inventory are associated with an increased prevalence of deck edge deterioration developing over time. When factoring in the lifetime costs of repairs needed to maintain open rail bridges, the benefits of closed rail become apparent.

Typically, the 42 in. rail has been used on high ADT and urban area structures.

It is not preferred to use 42 in. open rail on short stream crossings.

The 42 in. rail was originally tested at TL-5 using the previous standard of NCHRP 350. It is still approved for TL-5 use under the current standard of AASHTO MASH if used without a thick (such as AC+M) overlay. LRFDBDS Article 13.7.3.2 requires a 42 in. tall rail to qualify for TL-5.

LRFDBDS Article 13.8.1 requires 42 in. minimum rail height above the top of sidewalk. Previous practice was to install a steel Pedestrian Barrier Rail on top of lower height rails to make up the difference. This is not needed for 42 in. rails. Pedestrian Barrier Rails may still be necessary in certain situations, refer to §13.5.

The 39 in. rail was crash tested in 2018 with the report approved and published in 2021 at AASHTO MASH TL-4 level, including additional height for a 3 in. overlay (Rosenbaugh et al., 2021).

The 34 in. NU Closed rail requires more concrete than the 39 in. SSCR rail. Therefore, for closed rail, the 39 in. SSCR is preferred even when 34 in. NU Closed Rail is allowable.

For non-State owned structures, other MASH-tested rails may be used at an appropriate test level based on traffic volume and roadway design needs. An example of a TL-2 bridge rail for low volume road can be found in Rosenbaugh et al. (2020a).

13.1.1.2—Existing Bridges

Existing bridges should be investigated to determine deviations from the standard rail layouts. See §7.3.2 for additional information regarding existing Bridge Rails.

When widening an existing Bridge to one side, it is preferable to use a new MASH tested railing in the new construction. Consideration should be given to upgrading the non widened side to a new rail using engineering judgment.

13.1.2—Closed Rail Requirements

Closed Concrete Rail shall be used on all approach sections. If necessary, Roadway Design will provide inlets and surfacing to handle the drainage.

For bridges with sidewalks, all separation barriers on the bridge and approach sections shall be closed to prevent icing of the sidewalk.

For closed rails requiring deck drains on bridges with sidewalks, ensure that there is no conflict between the deck drains and the girder lines. This shall be determined during preliminary design.

All closed rail bridges will be reviewed by Bridge Hydraulics for Floor Drains. In certain situations, Bridge Hydraulics may recommend use of Open Concrete Rail instead, see §8.1.2 for more information.

Some of the factors Bridge Hydraulics considers when evaluating deck drainage are:

- Shoulder Width. In general, a Bridge with narrow shoulders (<4 ft.) requires more floor drains than a wider bridge at the same site.
- Longitudinal slope. A bridge with a slope of less than 0.5% is considered flat, which is less efficient at moving drainage off the deck than a bridge with a steeper grade.
- Location. The amount of rainfall in the western part of the state is less than that in the eastern part of the state, which may impact floor drain decisions.

13.1.3—Embankment Protection for Open Rails

Embankments above high water elevations are subject to compounding erosion from Open Concrete Rail drainage. Designers should be aware of erosion problems that may exist on-site and should recommend appropriate action to protect stream embankments.

13.1.4—General

Rail systems will be laid out and reinforced as shown on the Bridge Rail Base Sheets in [Appendix B](#).

The height of the vertical leg of the “L” shaped reinforcement will be sized to fit the bridge deck. The vertical leg will be designed to provide 3 in. minimum clearance to the top of the rail. Angled Bar Types shall be provided for cross slopes greater than 2.5% to eliminate field bending of the “L”.

Concrete Rail Sections are available as cells for use in detailing, see §13.8.

Quantities for the portion of concrete rail placed on the bridge deck will be listed as subitems under the bridge Pay Items. Quantities for the portion of concrete rail placed on the bridge approach slab will be listed as subitems under the Pay Items for the approach slab.

13.2—39 IN. RAILS

The 39 in. rail series were developed according to the criteria set forth in AASHTO's Manual for Evaluating Safety Hardware (MASH).

13.2.1—Single Slope Closed Rail

The 39 in. single slope rail is 8 in. wide at the top, sloping along the front face to 10 in. wide at the base of the rail (Rosenbaugh et al., 2021).

The distance from gutter line to edge of deck shall be 1 ft. 0 in. when this rail type is used.

The shape of the 39 in SSCR was designed to allow slip-forming.

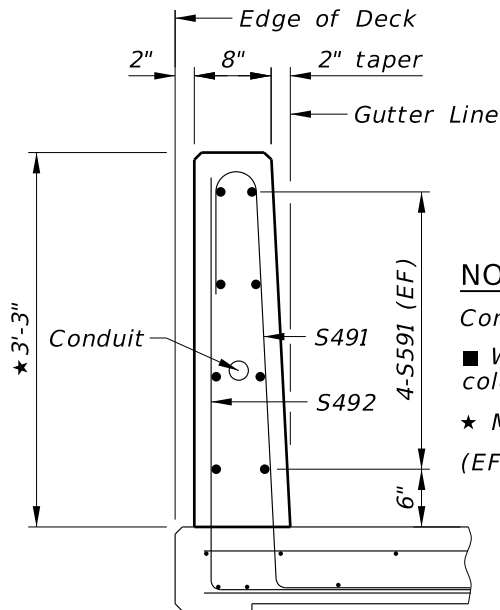

NOTES

Concrete rail and post will be built plumb.

■ When pouring concrete rails, a mandatory chamfered cold joint must be formed at the end of floor.

★ Measured at front face of rail.

(EF) = Each Face (FF) = Front Face (BF) = Back Face

TYPICAL SECTION OF RAIL

Figure 13.1—39 in. SSCR Bridge Rail Reinforcing

13.2.2—Open Concrete Rail

The 39 in. OCR consists of a 14 in. wide x 27 in. tall beam, with 3 ft. long x 10 in x 1 ft. tall interior posts and 6 ft. long x 10 in. x 1 ft. tall end posts (DeLone et al., 2023).

The system uses a 9 ft. maximum center to center post spacing over the length of the bridge. At the end posts the maximum clear span of the rail beam is 6 ft.

Typically the end span length is adjusted and the 9 ft. post spacing is maintained over the remainder of the bridge length. Where this results in unreasonably short end spans either the 9 ft. spacing can be adjusted full length or the end two spans of the rail can both be adjusted.

Vertical and horizontal layout dimensions shall be measured at the front face of rail.

The distance from Front face of Rail to edge of deck shall be 1 ft. 4 in. when this rail type is used.

To protect substructure elements, place a 6 in. concrete curb between rail posts over the interior supports as shown in the Base Sheet details.

For repair activities coinciding with AC+M overlay placing an FRP angle between posts to protect intermediate supports is also acceptable For other construction placing a 6 ft. end post centered over the interior supports is also acceptable alternative.

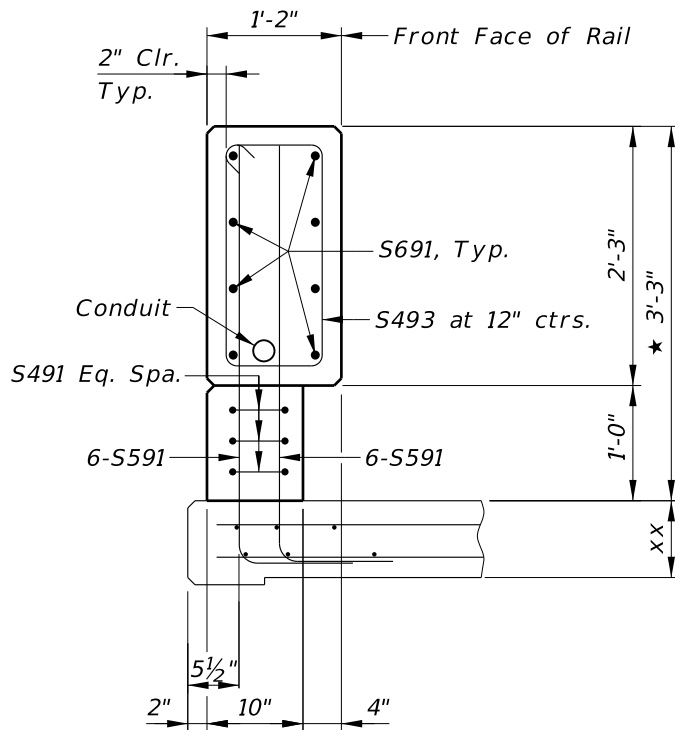
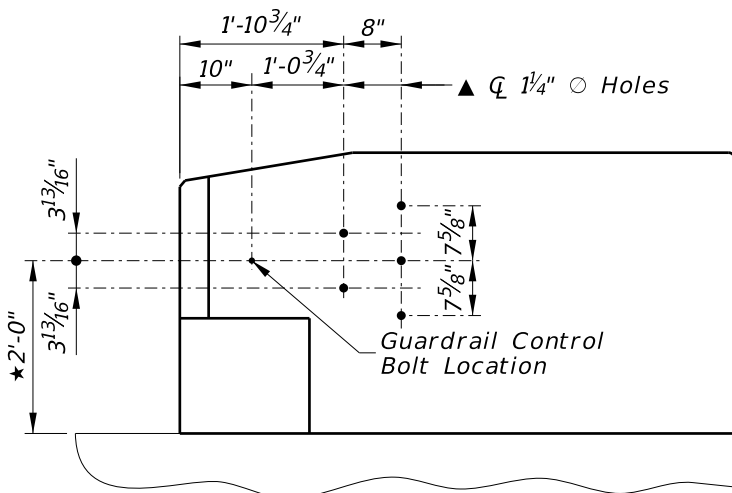

Figure 13.2—39 in. OCR Bridge Rail Reinforcing

13.2.3—Buttress Details

Designers are advised that the 39 in. Rail series utilize a different Buttress design than was used in the previous generation of Rails. The design has an upper and lower horizontal taper, as well as 4 in. vertical height transition on the end (Rosenbaugh et al., 2020b).

The Control Bolt location is 10 in. from the end of the Rail, which is 11 in. closer to the end of the rail than the previous generation of Rails.



THRIE BEAM TERMINAL CONNECTION DETAIL

Figure 13.3—39 in. Rail Buttress – Thrie Beam Terminal Layout

13.3—NU RAILS

The NU Rail Series were developed according to the criteria set forth in NCHRP Report 350, "Recommended Procedures for the Safety Performance Evaluation of Highway Features."

Vertical and horizontal layout dimensions for the NU Rail series shall be measured at the front face of rail.

The distance from Front face of Rail to edge of deck shall be 1 ft. 4 in. when this rail type is used.

13.3.1—NU Open Concrete Rail

The 34 in. OCR consists of a 14 in. wide x 23 in. tall beam, with 2 ft. 6 in. long x 10 1/2 in. wide x 11 in. tall interior posts and 4 ft. long x 10 1/2 in. wide x 11 in. tall end posts.

The system uses a 8 ft. maximum center to center post spacing over the length of the bridge. At the end posts the maximum clear span of the rail beam is 5 ft. 6 in.

The 42 in. OCR is the same as the alternate layout of the 34 in. rail with an additional 8 in. tall extension

Where 34 in. rails are specified, both the primary and alternate cells should be used on the plans in order to permit the use of steel forms purchased by some contractors. When showing existing rails in plans, inspections photos should be used to determine which profile was constructed.

Typically the end span length is adjusted and the 8 ft. post spacing is maintained over the remainder of the bridge length. Where this results in unreasonably short end spans either the 8 ft. spacing can be adjusted full length or the end two spans of the rail can both be adjusted.

The extension has a setback to prevent a vehicle occupant's head extending outside of the window during an oblique small car impact from contacting the barrier face (Polivka et al., 2005)

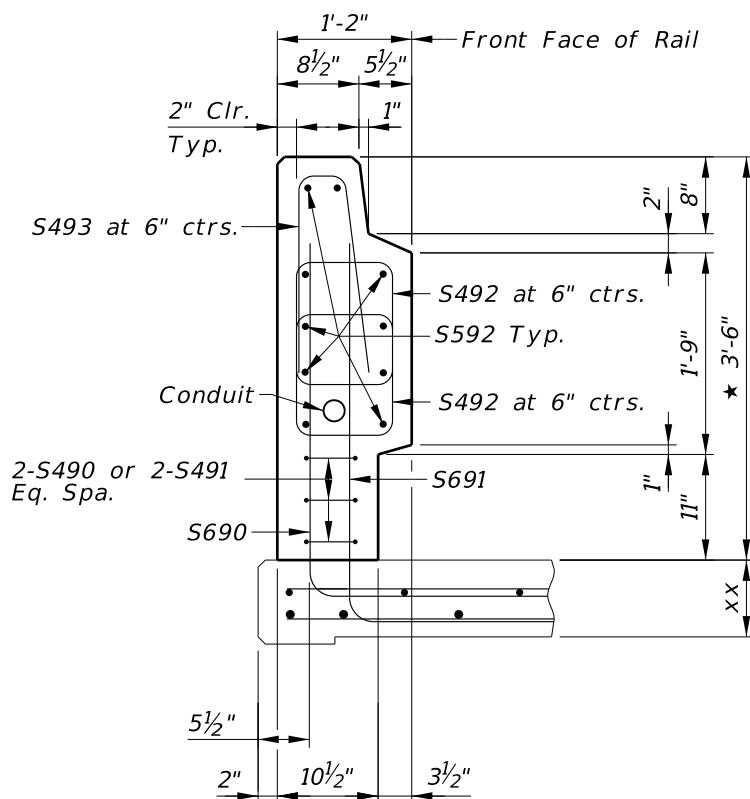

TYPICAL SECTION OF RAIL

Figure 13.4—NU Bridge Rail Reinforcing (shown here for 42 in. rail, see Base Sheets for 34 in. rail)

13.3.2—Buttress Details

Designers shall use the buttress design consistent with this generation of Rails (NCHRP 350).

The Control Bolt location is 1 ft. 9 in. from the end of the Rail.

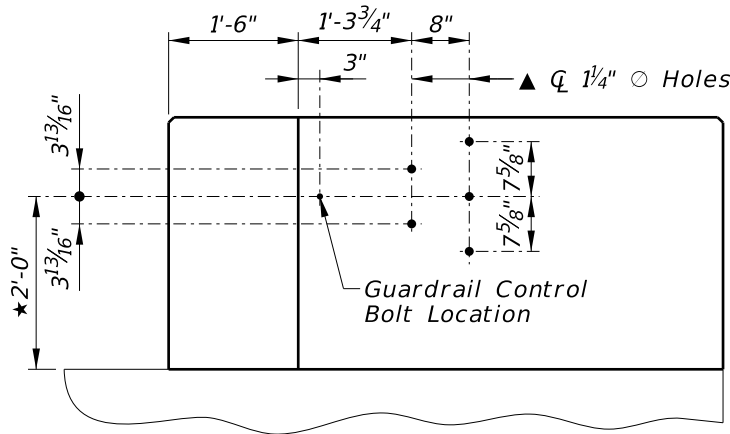

THRIE BEAM TERMINAL CONNECTION DETAIL

Figure 13.5—NU Bridge Rail Buttress — Thrie Beam Terminal Layout

13.4—LEGACY RAILS

13.4.1—Overview

Legacy Rails are concrete bridge rail types that are no longer specified for new construction on System Bridges but are acceptable to remain in place. For these rail types, cells are available for detailing in the Barriers and Rails cell library.

When it is necessary to repair, replace or extend these rail types on a bridge repair project, it is considered acceptable to match the existing geometry and reinforcement layout of the existing rail.

Per LRFDBDS Article 13.7.3.2, the minimum height of an existing concrete bridge rail to remain in place is 27 in. from the top of the wearing surface at the FF of the rail.

13.4.2—29 in. Nebraska Rail

The 29 in. Nebraska open rail consists of a 14 in. wide x 16 in. tall beam, with 2 ft. long x 11 in. wide x 13 in. tall interior posts and 3 ft. long x 11 in. wide x 13 in. tall end posts. The 29 in. Nebraska closed rail variant has the same cross section geometry without discrete posts.

The system uses a 8 ft. maximum center to center post spacing over the length of the bridge. At the end posts the maximum clear span of the rail beam is 6 ft. At locations where the rail beam must continue beyond a post up to a 1 ft 0 in. cantilever is acceptable.

Base sheets for these rail types are not available in OBM; however, the Base Sheets from the previous generation of MicroStation are still applicable. When remodeling these rail types, use engineering judgment to determine appropriate modifications from the available Base Sheets. For example, some existing Jersey Barriers are 15 in., they don't need to be widened to 16 in.

Some existing bridges use a previous version of the 29 in. tall Nebraska Rail that used a 14 in wide x 12 in tall beam, with 11 in. long x 11 in. wide x 17 in. tall posts. This rail shall not be used anymore. Only use the version described in Figure 13.6 when permissible.

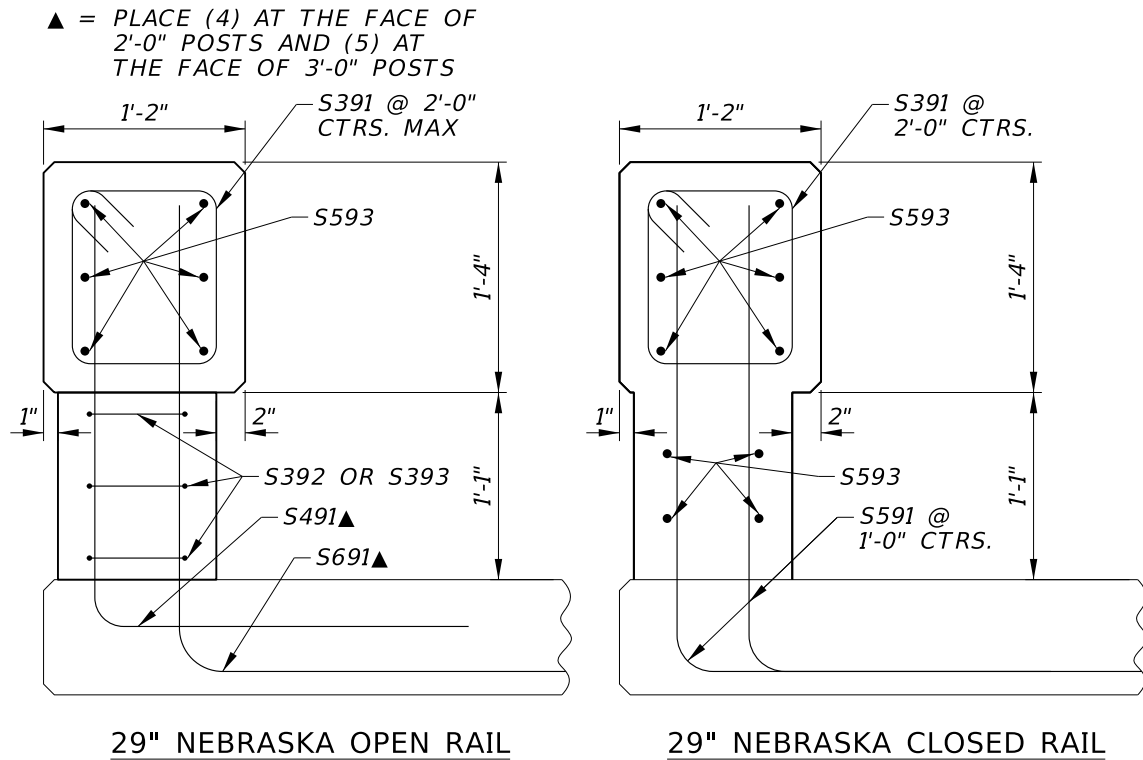

Figure 13.6—29 in. Nebraska Rail Reinforcing Sections

13.4.3—Concrete Barrier

The concrete barrier consists of a 32 in. or 42 in. tall New Jersey shaped section. All layout dimensions for the barrier will be measured at the gutter line (front face) of the barrier.

All longitudinal bars in the concrete barrier will be # 4 bars. In addition, there are four continuous bars placed in the bridge deck.

The 123, 125, and 126 type stirrups will match a spacing provided in the bridge deck, up to a maximum spacing of 1 ft. 3 in.

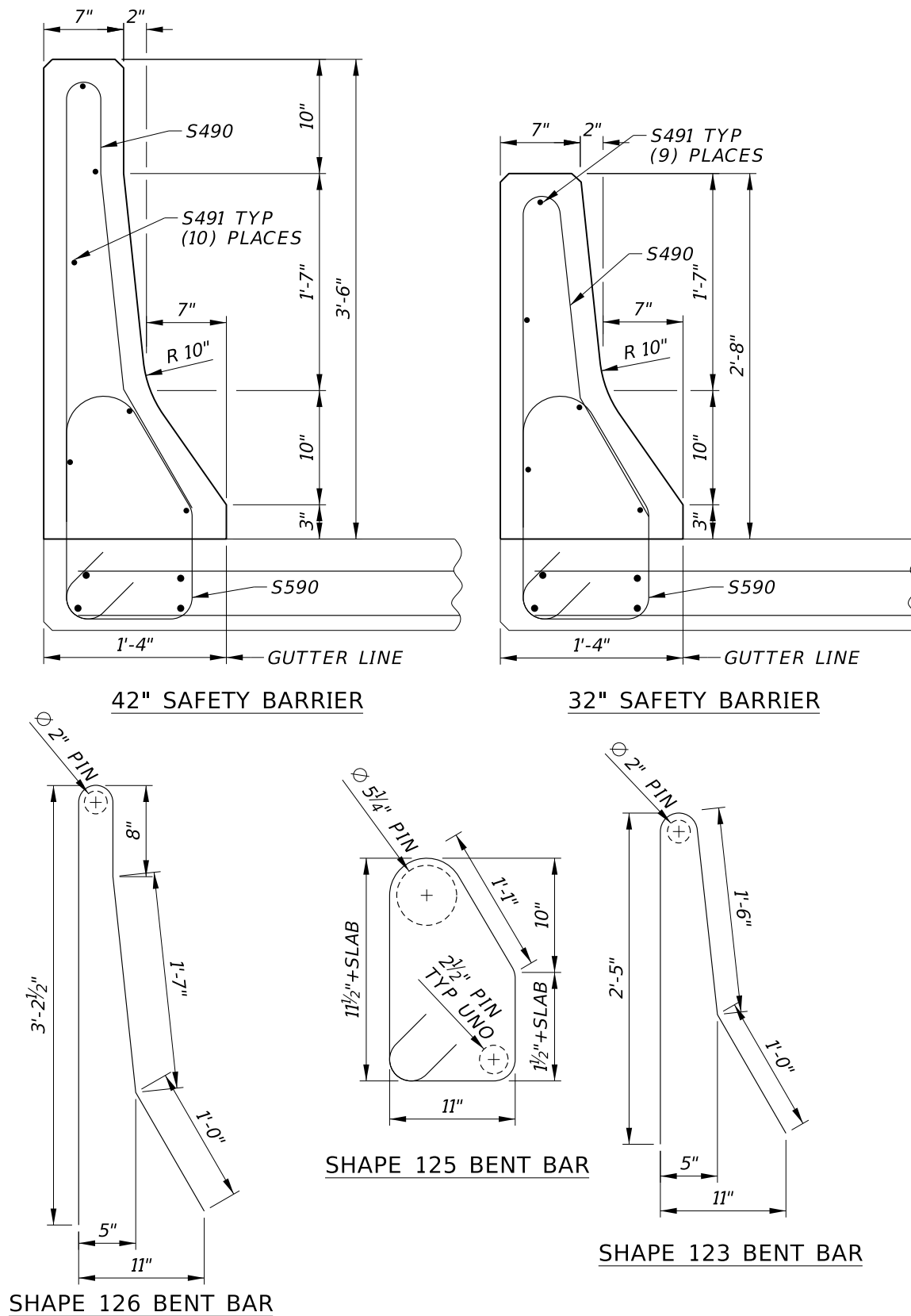

Figure 13.7—Concrete Barrier Reinforcing Sections

13.4.4—Thrie Beam Guardrail Connections for Legacy Rails

13.4.4.1—Use of Standard End Sections (NCHRP 350)

The standard End Section for the Legacy Rails on Approach Slab is shown in Figure 13.8. This section utilizes fully developed #6 L bars at approx. 5 in. centers in each face for the deck to rail connection.

When designing rail updates on an existing bridge, the standard end section should be utilized as much as possible.

See §7.3.2.1 for guidance regarding the location of the guardrail connection.

In most situations, the typical Standard End Section length of 5 ft. shall be used. However, because this system was designed with an allowance for a 2 ft. blockout on each side of the expansion joint, the absolute minimum length of a Standard End Section is 3 ft.

Designers are encouraged to remove and rebuild a portion of the deck edge, wingwall, or both as needed to install a standard end section, in lieu of using adhesive anchor bars (also known as dowels) to make the rail connection. The design of adhesive anchors take into account failure modes that do not apply to cast-in fully developed reinforcement.

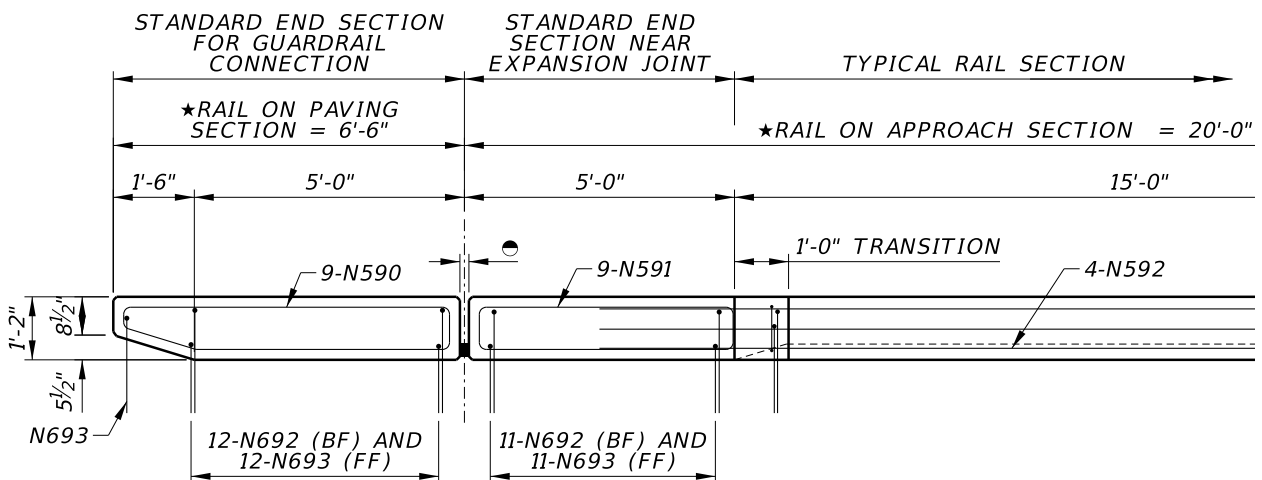

Figure 13.8—Plan View of Standard Legacy Rail End Sections (NCHRP 350)

13.4.4.2—Thrie-Beam Guardrail Connections

All layout dimensions for guardrail connections will be measured at the Gutter Line / Front Face of Rail.

New guardrail connections shall consist of a Rectangular End Section with a 1 ft 6 in. taper added to the end.

The height of the End Section shall be 35 in. at the Guardrail Connection, measured from the top of the concrete slab. The Control Bolt location is 1 ft. 9 in. from the end of the Rail, shown to be installed 24 in. from the top of the slab, see Figure 13.10.

For existing Bridge Rails, designers shall transition the height of the existing rail as needed to provide 35 in. at the End Section. This height transition shall be no steeper than 1V:8H. Transitions from existing rail geometry to the constant width End Section shall be done as shown in the Rail Base Sheets.

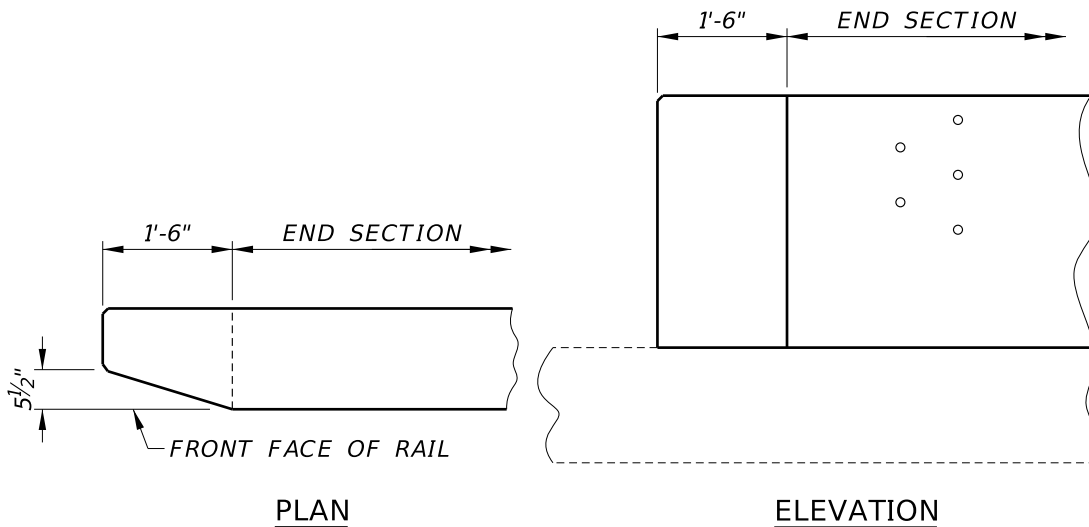
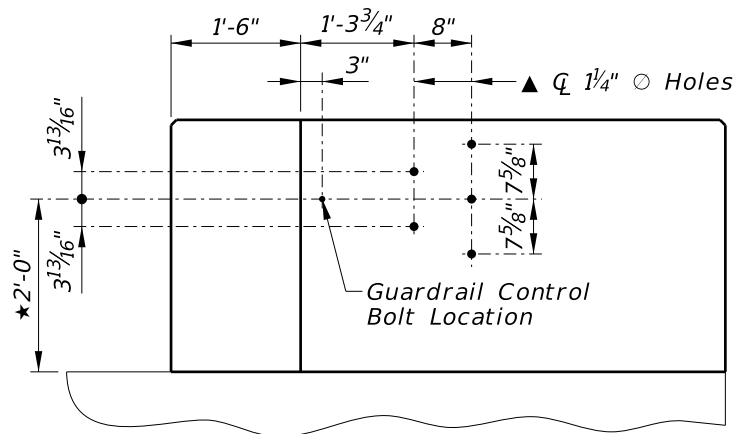

Figure 13.9—Legacy Rails – Guardrail End Section Dimensions

★ Measured at front face of rail.

(EF) = Each Face (FF) = Front Face (BF) = Back Face

▲ As an alternate method, the contractor shall furnish and cast into the concrete an approved welded assembly consisting of threaded inserts, held accurately to the template of the holes shown. Inserts are to be complete with galvanized plate washers and galvanized 7/8" \odot x 2" cap screws. The insert assembly shall be a standard product of a reputable manufacturer of such items and be capable of resisting a shear load of 80,000 lbs.



THRIE BEAM TERMINAL CONNECTION DETAIL

Figure 13.10—Legacy Rails – Thrie Beam Terminal Layout

13.5—PEDESTRIAN BARRIER RAILS

End treatments for pedestrian barriers shall be coordinated with Roadway Division.

Pedestrian Barriers on Legacy Rails is allowed only as in-kind replacement or on existing bridges where the use of 42 in. tall rail adjacent to the sidewalk would result in different sized rail on each side of the bridge. A Base Sheet is available for the Pedestrian Barrier Rail.

See §§ 2.10 and C13.1.1.2 for sidewalk barrier recommendations.

13.6—FENCE

13.6.1—Pedestrian Fence

Pedestrian fences are required adjacent to sidewalks or trails on bridges.

Provide one of the following for bridges that are over roadway traffic:

- 8 ft. 3 in. high, curved chain-link fence
- minimum 10 ft. high straight, anti-climb mesh

This is to provide protection from falling debris for the traffic below.

Provide a 6 ft. high straight, chain-link fence or anti-climb mesh for bridges that are not over roadway traffic or railroad.

Some municipalities have their own local fence rules that may need to be coordinated with these rules.

13.6.2—Railroad Protection Fence

Railroad protection fences are required within the limits of the Railroad Right-of-Way or a minimum of 25 ft. beyond the centerline of the outermost existing track, future track, or access road, whichever is greater.

Railroad protection fences shall be provided on both sides of structures over railroads.

For edges of structures without pedestrian access provide a minimum 10 ft. high straight chainlink or anti-climb mesh fence. For edges of structures with a sidewalk or trail provide one of the following:

- 8 ft. 3 in. high, curved chain-link fence
- minimum 10 ft. high straight, anti-climb mesh

13.6.3—Fence Layout

All fence layouts should be located on the bridge using dimensions from the end(s) of the bridge floor at the centerline of the fence. The maximum post spacing shall be 8 ft. for all posts. For fence types that require bracing, the first bay of each end shall be 8 ft. and the second bay shall vary to accommodate any odd lengths required.

All fence heights are measured from the top of the sidewalk.

13.6.4—Expansion Joints

Expansion joints shall be provided in the all longitudinal members and handrail at all bridge expansion locations in the bridge deck and at end of floor (where present). Typical fence bracing should be provided on both sides of expansion joints.

Expansion gaps should be designed for a fixed dimension (i.e., no adjustments for temperature at time of installation). Expansion gaps greater than 2 in. should use a longer pipe on the inside of the joint.

13.6.5—Base Sheets

Base sheets are currently available for:

- 8 ft. 3 in. high curved pedestrian fence (chain link type) which has 6 ft. high sections at the ends.
- 10 ft. 6 in. high railroad protection fence

The following minimum information shall be populated into the base sheets:

- The clear dimension of the sidewalk should be indicated on the “Typical Section Thru Fence.”
- “Typical Section Thru Fence” will indicate the proper traffic barrier used on the bridge project.
- The fence layout will indicate the odd post spacing and number of 8 ft. spaces.
- The expansion gap distance should be shown in the “Expansion Joint / Splice Detail.” This information should be placed with the note for intermediate splice dimensions.

Designers should note that the minimum clear dimension of the sidewalk is on the approach slab when using the 39 in. SSCR, see Figure 13.11.

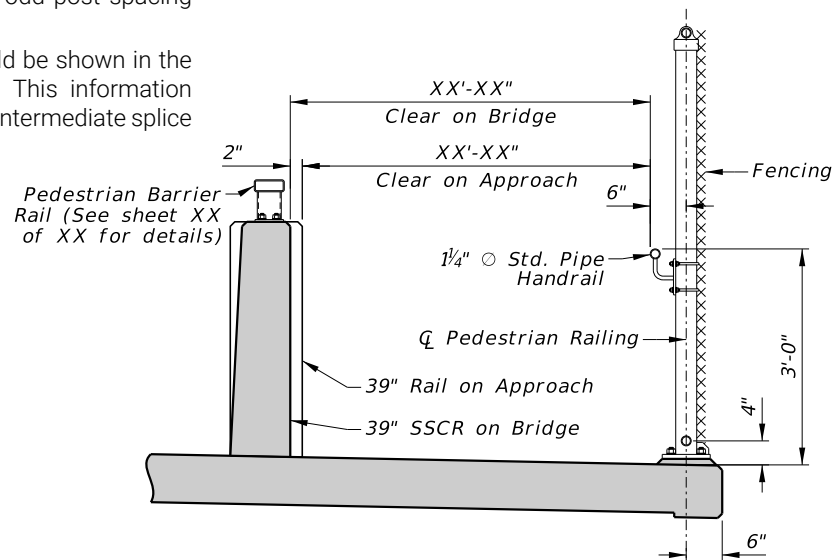

TYPICAL FENCE SECTION

Figure 13.11—39 in. SSCR Sidewalk Clear Width

13.7—REFERENCES

DeLone, J. A., Faller, R. K., Rasmussen, J. D., Rosenbaugh, S. K., & Bielenberg, R. W. (2023). *Development of a MASH Test Level 4 Open Concrete Bridge Rail* (Technical Report TRP-03-406a-23). Midwest Roadside Safety Facility (MwRSF) Nebraska Transportation Center University of Nebraska-Lincoln, Iowa Department of Transportation, Kansas Department of Transportation, Nebraska Department of Transportation, South Dakota Department of Transportation, & Virginia Department of Transportation. <https://mwrsf.unl.edu/researchhub/files/Report485/TRP-03-406a-23.pdf>

Polivka, K. A., Faller, R. K., Holloway, J. C., Rohde, J. R., & Sicking, D. L. (2005). *Development, Testing, and Evaluation of NDOR’s TL-5 Aesthetic Open Concrete Bridge Rail* (Technical Report TRP-03-148-05). Midwest Roadside Safety Facility (MwRSF) Nebraska Transportation Center University of Nebraska-Lincoln & Nebraska Department of Roads. <https://mwrsf.unl.edu/researchhub/files/Report82/TRP-03-148-05.pdf>

Rosenbaugh, S. K., DeLone, J. A., Faller, R. K., & Bielenberg, R. W. (2020a). *Development and Testing of a Bridge Rail for Low-Volume Roads* (Technical Report TRP-03-407-20). Midwest Roadside Safety Facility (MwRSF) Nebraska Transportation Center University of Nebraska-Lincoln. <https://mwrsf.unl.edu/researchhub/files/Report339/TRP-03-407-20.pdf>

Rosenbaugh, S. K., Faller, R. K., Asselin, N., & Hartwell, J. A. (2020b). *Development of a Standardized Buttress for Approach Guardrail Transitions* (Technical Report TRP-03-369-20). Midwest Roadside Safety Facility (MwRSF) Nebraska Transportation Center University of Nebraska-Lincoln. <https://mwrsf.unl.edu/researchhub/files/Report415/TRP-03-369-20.pdf>

Rosenbaugh, S. K., Faller, R. K., Dixon, J., Loken, A., Rasmussen, J. D., & Flores, J. (2021). *Development and Testing of an Optimized MASH TL-4 Bridge Rail* (Technical Report TRP-03-415-21). Midwest Roadside Safety Facility (MwRSF) Nebraska Transportation Center University of Nebraska-Lincoln. <https://mwrsf.unl.edu/researchhub/files/Report433/TRP-03-415-21.pdf>

13.8—REFERENCED CELLS

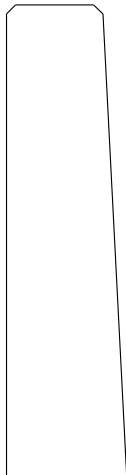

Figure 13.12— Rail Sec 39 SSCL Cell
(Barriers and Rails Library)



Figure 13.13—Rail Sec 39 OCBR Cell
(Barriers and Rails Library)



Figure 13.14—Rail Sec 42 NUCL Cell
(Barriers and Rails Library)

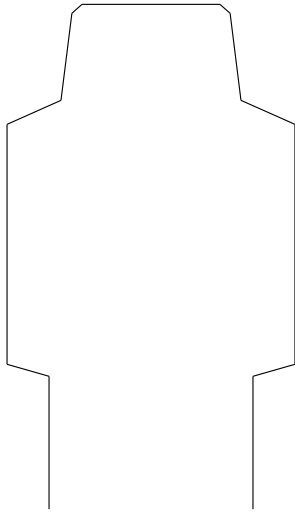

Figure 13.15—Rail Sec 42 NUMD
Cell (Barriers and Rails Library)

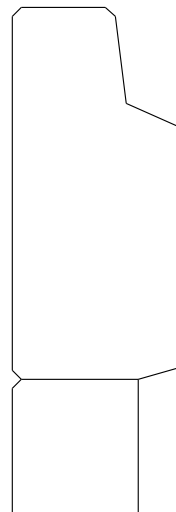

Figure 13.16—Rail Sec 42 NUOP Cell
(Barriers and Rails Library)

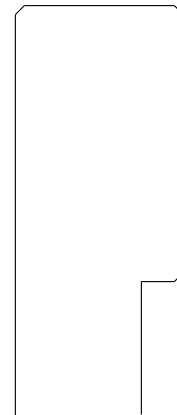

Figure 13.17—Rail Sec 34 NUCL Cell
(Barriers and Rails Library)

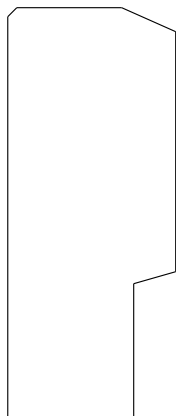

Figure 13.18—Rail Sec 34 NUCL Alt
Cell (Barriers and Rails Library)

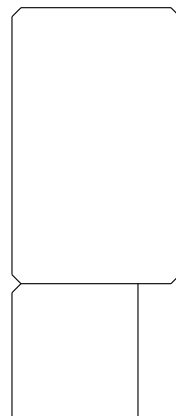

Figure 13.19—Rail Sec 34 NUOP Cell
(Barriers and Rails Library)

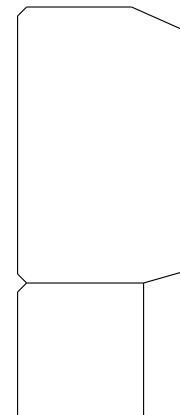

Figure 13.20—Rail Sec 34 NUOP Alt
Cell (Barriers and Rails Library)

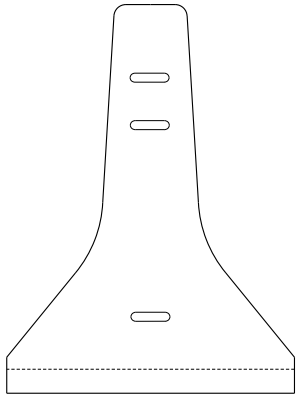

Figure 13.21—WP Barrier Sec Cell (Barriers and Rails Library)

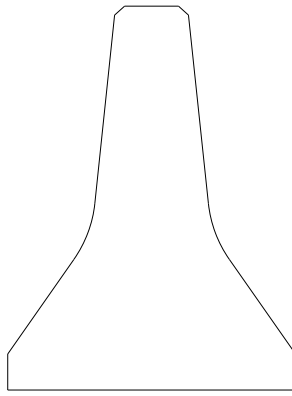

Figure 13.22—Temp Barrier Sec Cell (Barriers and Rails Library)

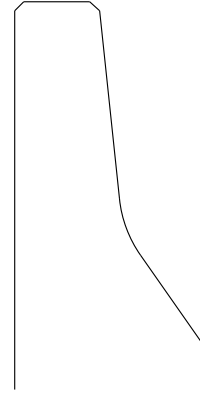

Figure 13.23—Ex Barrier Sec 32 NJ Cell (Barriers and Rails Library)

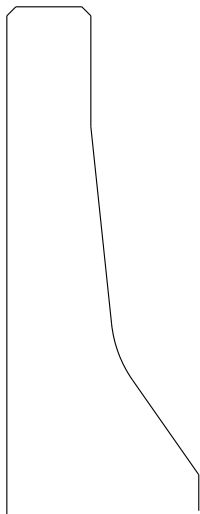

Figure 13.24—Ex Barrier Sec 42 NJ Cell (Barriers and Rails Library)

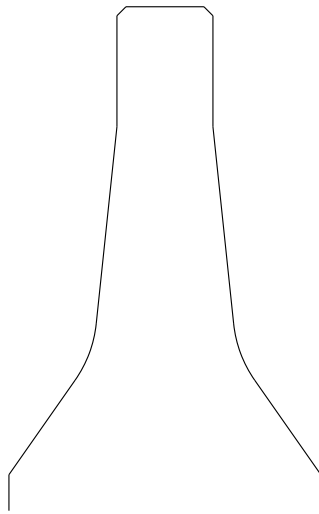

Figure 13.25—Ex Barrier Sec 42 NJMD Cell (Barriers and Rails Library)

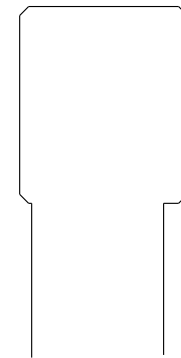

Figure 13.26—Ex Rail Sec 29 NEBCL Cell (Barriers and Rails Library)

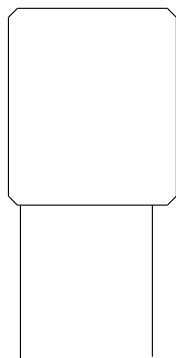

Figure 13.27—Ex Rail Sec 29 NEBOP Cell (Barriers and Rails Library)

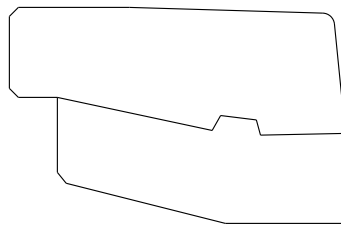

Figure 13.28—Ex Curb Sec 10.5 Cell (Barriers and Rails Library)

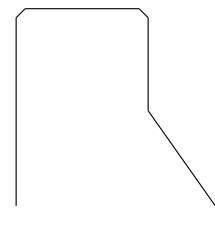

Figure 13.29—Ex Curb Sec 20 Cell (Barriers and Rails Library)

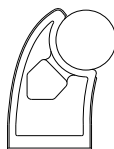

Figure 13.30—Ex Rail Sec 1755C Cell (Barriers and Rails Library)

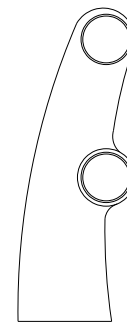

Figure 13.31—Ex Rail Sec 1753C Cell (Barriers and Rails Library)

Last Updated: January 13, 2025