



# Investigating the Interaction of NDOT Hot-Pour PCC Joint Sealant and Penetrating Concrete Sealers

## **Principle Investigator:**

Bruce Barrett  
Pavement Design Engineer

## **Technical Advisers:**

Dale Byre  
Hwy Materials & Research Manager

Wally Heyen  
PCC Engineer

Lieska Halsey  
Assistant Materials Engineer

David Hansen  
Chemical Engineer

## Background

In May 2019, Nebraska Department of Transportation (NDOT) Project Managers and contractors observed discoloration and apparent dissolution of the hot-pour joint sealant during application of penetrating concrete sealer (PCS) to the exit ramps on NE-83 near North Platte, NE. Discoloration is shown in Figure 1. Contractors sealed the joints with NDOT designation NE-3405 (NE-3405) hot-pour sealant and applied NDOT approved PCS on the concrete surface.

NDOT conducted research in February 2018 and determined the bond between sealant and concrete is not compromised by PCS approved by NDOT at the time of the study <sup>[1]</sup>. In the [2018 study](#), researchers applied PCS to the interfacial surface of concrete blocks prior to filling them with hot-pour sealant.

Based on the field observations on NE-83, PCS potentially impacts the bond between the concrete and hot-pour sealant after application. If penetrating sealers break the interfacial bond after application, concrete pavements could become compromised and subject to freeze-thaw damage, chloride attack, and other deleterious effects.

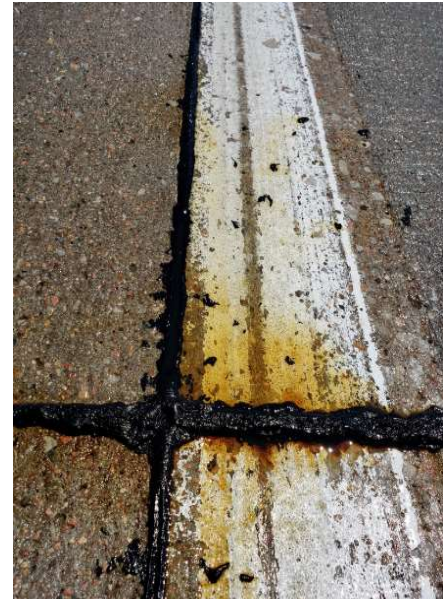

Figure 1 - Discoloration appeared at the joint after contractors applied penetrating concrete sealer.

## Purpose of the Investigation

The purpose of this investigation was to identify detrimental effects to the interfacial bond between the hot-pour sealant and the concrete pavement after applying Department approved PCS.

## Laboratory Investigation

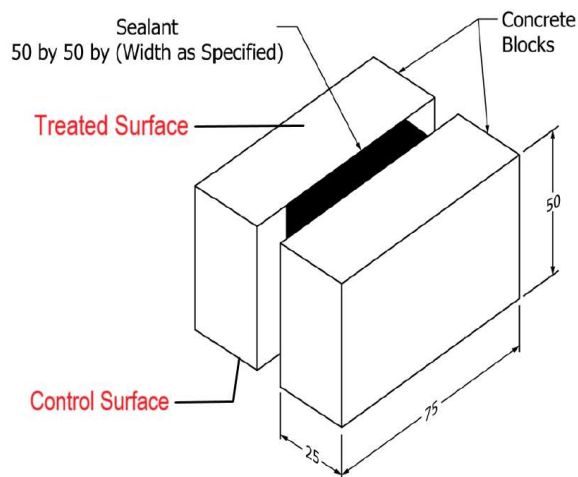

Figure 2 - The diagram of the concrete extension blocks from ASTM D5329 <sup>[2]</sup>. The treated and control surfaces are identified by NDOT researchers.

The investigation commenced with a meeting between researchers and Technical Adviser Committee (TAC) members. During this meeting, a plan was developed to test the five PCS products approved by the Department in accordance with ASTM D5329, *Standard Test Methods for Sealants and Fillers, Hot-Applied, for Joints and Cracks in Asphalt Pavements and Portland Cement Concrete Pavements*<sup>[2]</sup>. After testing completed, a TAC member proposed constructing a modified cupped block to model a depression observed in field application of hot-pour sealant. A set of blocks was constructed following ASTM D5329 with a modification in the form to create a depression. Construction and testing details of each block type are discussed in the following sections. Figure 2 shows a diagram of a block with dimensions in millimeters and illustrates the treated surface and the control surface.

## Extension Testing



Figure 3 – NDOT designation NE-3405 from production batch W23348 was used in research.

The bituminous lab constructed six sets of three concrete blocks according to ASTM D5329. NDOT designation NE-3405 sealant from Batch W23348, shown in Figure 3, was used to construct the blocks. The batch was from an adjacent production lot to the sealant used on the NE-83 project.

Researchers applied PCS on the surface of the blocks after they were filled with hot-pour sealant to mimic field application on a project. The five PCS products were applied to the blocks by either spraying or soaking and allowed to dry. Then the interfacial bonds were tested through extension testing according to ASTM D5329. PCS product 1 was obtained from the NE-83 project and from the supplier. All other PCS products, 2-5, were obtained from the supplier. Product 5 was also used in the modified cupped block testing. The testing matrix is summarized in Table 1.

**Table 1 - The testing matrix for extension testing describes the construction technique for the blocks and which PCS product they were treated with during the experiment.**

Block Set	Block Set Construction	PCS Product
1	ASTM D5329	Product 1 — From NE-83 Project
2	ASTM D5329	Product 1 — From Supplier
3	ASTM D5329	Product 2 — From Supplier
4	ASTM D5329	Product 3 — From Supplier
5	ASTM D5329	Product 4 — From Supplier
6	ASTM D5329	Product 5 — From Supplier
7	ASTM D5329* - Modified Cupped	Product 5 — From Supplier

One set of three blocks was tested for each product. The first block was sprayed twice with PCS on the surface, identified as the treated surface shown in Figure 2. The PCS was applied using a handheld mist sprayer and left to sit on the table top. The remaining two blocks were placed face down in two separate CoorsTek 60236 Porcelain Ceramic Evaporating Dishes each containing 15mL of PCS. The second block soaked for 1 minute, and third block soaked for 5 minutes. The PCS was approximately 1 mm deep but the blocks wicked up the PCSs approximately 3-6 mm, shown in Figure 4. Visual observations were noted and are discussed in the results section. For a control, researchers examined the opposite side of the block that was not treated with PCS, defined as the control side in the diagram shown in Figure 2.

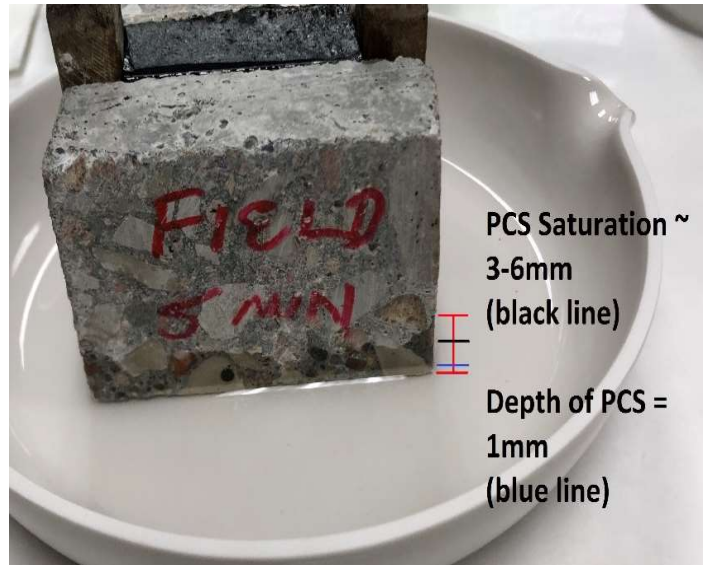

Figure 4 - Blocks were soaked in PCS at a depth of 1mm. The PCS wicked up the block 3-6 mm.

After the PCS was sprayed or soaked and allowed to dry, all blocks were tested in accordance with ASTM D5329. The blocks were inspected for damage and de-bonding to the hot-pour and to the interfacial bond on all surfaces of each block. Results are discussed later in this paper.

## Modified Cupped Blocks



Figure 5 - A set of blocks was modified to create a cupped depression in the hot-pour sealant.

A set of three blocks was constructed with a modified mold designed to provide a cupped surface. Cupping is a depression created as hot pour sealant settles and cools in a joint and has been observed in the field. Cupping causes liquids to pond on the surface of the hot pour sealant. To create the depression, or cup, the physical testing laboratory provided the bituminous lab with a ½-round bar of 12.7 mm diameter, and 38 mm length. The bar was placed in the mold and the testing blocks were made in accordance with ASTM D5329. For this experiment, the three cupped blocks were ponded with Product 5 and allowed to evaporate and dry prior to extension testing. One of cupped blocks was photographed during the testing process. The cupped depression, boxed in red, is shown in Figure 5.



## Results

### Product 1 – Project Sample



Figure 6 - The sprayed block was swabbed at the interfacial bond. The swab shows discoloration occurred after spraying.

The first set of blocks tested with Product 1 obtained from the project all showed discoloration. The sprayed block was swabbed at the interfacial bond which revealed discoloration as shown in Figure 6. The 1-minute and 5-minute soaked blocks both showed discoloration in the dishes. Expectedly, the 5-minute soak produced a darker color than the 1-minute soak, shown in Figure 7. Researchers observed a small amount of solids in the dish. The solids appeared to be small pieces of aggregate that scaled off during the soaking period. All Product 1 blocks passed all three extension tests. The results are summarized in Table 2.

Table 2 - Product 1 Obtained from the Field

Field Sample of Product 1	Discoloration	Extension Test
Sprayed Block	Yes – observed within 5 minutes after spray	Pass
1-minute Block	Yes – observed upon removing block from soak	Pass
5-minute Block	Yes – observed upon removing block from soak	Pass



Figure 7- The Product 1 field sample 1-minute soaking dish (top) and the 5-minute soaking dish (bottom) each showed discoloration of the penetrating concrete sealer. The 5-minute soak shows more dissolution than the 1-minute soak.

### Product 1 – Supplier Sample

The second set of blocks tested with Product 1 received from the supplier exhibited similar levels of discoloration and dissolution as the field supplied sample shown in Figure 8. All blocks passed the extension test. Results are summarized in Table 3.

**Table 3 - Product 1 Obtained from the Supplier**

Supplier Sample of Product 1	Discoloration	Extension Test
Sprayed Block	Yes – observed 5 within minutes after spray	Pass
1-minute Block	Yes – observed upon removing block from soak	Pass
5-minute Block	Yes – observed upon removing block from soak	Pass



Figure 8 - Product 1 from the supplier showed similar results as the Product 1 field sample.

### Product 2 – Supplier Sample

Product 2 exhibited discoloration and dissolution, shown in Figure 9. All blocks passed the extension test. The results are summarized in Table 4.

**Table 4 – Product 2 Obtained from the Supplier**

Product 2	Discoloration	Extension Test
Sprayed Block	Yes – observed within 5 minutes after spray	Pass
1-minute Block	Yes – observed upon removing block from soak	Pass
5-minute Block	Yes – observed upon removing block from soak	Pass



Figure 9 - The Product 2, 1-min (left) and 5-min (right) tests show dissolution.

### Product 3 – Supplier Sample

Product 3 exhibited discoloration and dissolution, shown in Figure 10. All blocks passed the extension test. The results are summarized in Table 5. Product 3's 1-minute block showed some debonding along one side edge after the 3rd pull. The debonding is shown in Figure 11. The edge that debonded was not exposed directly to the PCS, however wicking might have drawn PCS up the side of the block. Inspection showed a pit, possibly caused by loose aggregate in the concrete block, where the debonding occurred. Researchers concluded that this damage was not caused by PCS.

**Table 5 - Product 3 Obtained from the Supplier**

Product 3	Discoloration	Extension Test
Sprayed Block	Yes – observed within 5 minutes after spray	Pass
1-minute Block	Yes – observed upon removing block from soak	Pass
5-minute Block	Yes – observed upon removing block from soak	Pass



Figure 10 - Product 3, 1-min. and 5-min. post-test dishes showing discoloration.

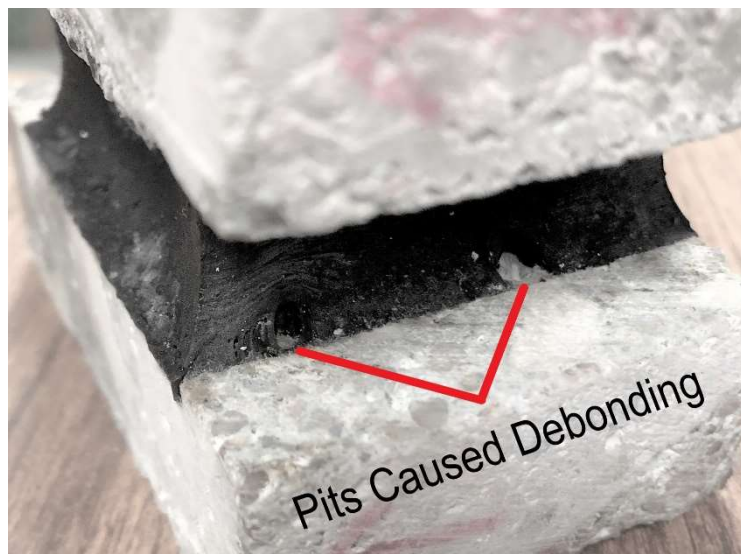

Figure 11 - The debonding along a side edge was likely caused by loose aggregate in the block rather than PCS wicking up the block. The PCS treated side is left-facing.

### Product 4 – Supplier Sample

Product 4 showed more discoloration than Products 1, 2, and 3. The discoloration is shown in Figure 12. All blocks passed the extension test. The results are summarized in Table 6.

**Table 6 - Product 4 Obtained from the Supplier**

Product 4	Discoloration	Extension Test
Sprayed Block	Yes – slight; observed within 5 minutes after spray	Pass
1-minute Block	Yes – observed upon removing block from soak	Pass
5-minute Block	Yes – observed upon removing block from soak	Pass



Figure 12 - Discoloration from the Product 4 testing was more intense than in Products 1, 2, and 3. The 5-min dish (top) also shows some solids falling off the block.



## Product 5 – Supplier Sample

Product 5 showed the most discoloration of all products, shown in Figure 13. Researchers observed small particles floating in the dish, shown in Figure 14. After the third extension, researchers observed that sealant flowed down the side of the block, as shown in Figure 15. Researchers also observed that sealant treated with Product 5 was sticky. Despite these observations, all blocks passed the extension test. The results are summarized in Table 7.

**Table 7 - Product 5 Obtained from the Supplier**

Product 5	Discoloration	Extension Test
Sprayed Block	Yes – observed within 5 minutes after spray	Pass
1-minute Block	Yes – observed upon removing block from soak	Pass
5-minute Block	Yes – strong; observed upon removing block from soak	Pass



Figure 13 - Product 5; the 5-min (bottom dish) soak showed the most discoloration of any of the tests.



Figure 14 - The 5-min soak of Product 5 left solids in solution.



Figure 15 – NE-3405 sealant ran down the face of Product 5's 5-minute block.

## Product 5 - Modified Cupped Blocks

Product 5 was poured into the cupped depression in the modified cupped blocks. The blocks were left in the ponded state at room temperature in the Bituminous Lab until the PCS had dried or evaporated after approximately 5-7 days. The blocks were turned on their sides in preparation for the pull testing and during that time, the hot pour sealant flowed onto the table surface as shown in Figure 16. All of three blocks passed the extension test. The results are summarized in Table 8.



Figure 16 - Hot pour sealant flowed out of the cupped blocks after being ponded with Product 5.

Table 8 – Cupped Blocks with Product 5 Obtained from the Supplier

Product 5	Discoloration	Extension Test
Block 1	Yes – Hot pour sealant flowed from test block	Pass
Block 2	Yes – Hot pour sealant flowed from test block	Pass
Block 3	Yes – Hot pour sealant flowed from test block	Pass

## Conclusions and Recommendations

The results show that discoloration occurred when applying the five PCS products to the NE-3405 hot-pour sealed testing blocks. All three test methods of application; spraying, 1-min, and 5-min soaks, caused discoloration. The level of discoloration increased with the duration of contact with the PCS. Despite discoloration, none of the five PCS products caused de-bonding issues during extension testing which concludes that the PCS products do not deteriorate of the interfacial bond between NE-3405 hot-pour sealant and concrete surfaces. Maintenance crews and contractors should be advised that some discoloration is normal and should not cause concern.

## Acknowledgements

John Gude from the Materials and Research Bituminous Laboratory who constructed the blocks and performed all testing.

## References

- [1] Halsey, L. et al, 2018, "Hot Applied Sealant Bond Test for Joints with Penetrating Sealers," 2018, Nebraska Department of Transportation, Materials and Research Division, Lincoln, NE., <https://dot.nebraska.gov/media/11499/2018-hot-applied-sealant-bond-test.pdf>
- [2] ASTM D5329, 2016, "Standard Test Methods for Sealants and Fillers, Hot-Applied, for Joints and Cracks in Asphalt Pavements and Portland Cement Concrete Pavements," ASTM International, West Conshohocken, PA, 2016, DOI:10.1520/D5329-16, [www.astm.org](http://www.astm.org)