

Executive Summary and Research Readiness Level Assessment

Hot Applied Sealant Bond Test for Joints with Penetrating Sealers

Research Objectives

1. Evaluated approved penetrating concrete sealers categorized for construction use.
2. Evaluated hot applied sealant bond for joints with penetrating sealers in accordance with ASTM D 5329.

Research Benefits

The expected results was that the bond was not compromised and is serving for the expected joint service life.

Principal Investigators

Lieska Halsey (P.I.)

Nebraska Department of Transportation

Bituminous Laboratory

John Gude, Hwy Quality Assurance Manager

Technical Advisor

Daly Byre, Highway Materials & Test Manager

Background

Recently a concern had been raised for hot applied sealant bond for joints with penetrating sealers. This research determined if the bond between the sealant and the concrete was compromised by the sealer currently approved to be used in Nebraska.

Scope of the Laboratory Testing

The ASTM D 5329 test method covers the testing for hot-applied types of joint sealants and fillers for portland cement concrete. The sealant used for the evaluation was crafcoc NE- 3405. Three concrete blocks were tested for each sealer evaluated. Figure 1 (see page 2) shows the concrete blocks specimens. Each sealer was applied and let dry for 24 hrs. on the concrete surface side of hot sealant application, Figure 2. The maximum heating temperature for the sealant according to the manufacturer recommendation was 400°F. Each product was evaluated with three blocks at 0°F for three cycles called 100% extension at low temperature. At the end of each cycle the specimens are removed from the extension machine, Figure 3. Examined the specimens for obvious separations within the sealant and between the sealant and the blocks, Figure 4. After inspection replace the spacer strips, return to storage, or room temperature, for 2 hours and rest each specimen on one concrete block so that the weight of the top block recompresses the joint sealant, Figure 5. Each cycle will follow the same procedure until the end of three cycles.

Conclusion

After the completion of 3 cycles for each product evaluated, each sample had passing results, see (Table 1) with the penetrating sealer.

Designation Name	After 3 Cycles	Cracks/De-bonded > ¼"
Product 1	Pass	None
Product 2	Pass	None
Product 3	Pass	None

Table 1

Executive Summary and Research Readiness Level Assessment

Interested in finding out more?
Final report is available:
[HERE](#)

NDOT Recommendations Based Off of Research

The application of sealers as a preventive maintenance tool for pavements started in 2018. The Department maintains a list of products that are prequalified for use on Nebraska Department of Transportation Construction and Maintenance projects. The hot applied sealant bond for joints with penetrating sealers test will be utilized before the sealer is approved.

2020 Update: Based on the testing that has been completed since the completion of this research, the DOT has seen no failures and will discontinue this test method.

By Lieska Halsey, Principal Investigator

Research Readiness Level (RRL) Assessment

RRL 5

Level 5: Standard Practice

Research/Technology fully implemented and understood. No follow-up is necessary.

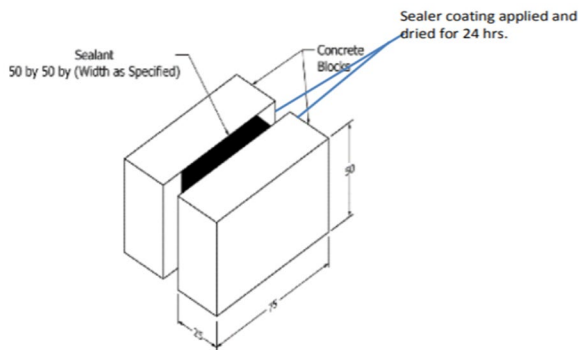

Figure 1. Concrete Block Test Specimen) ASTM D 5329 (1)



Figure 2. Sealer Application



Figure 3. Concrete Blocks on Extension Machine



Figure 4. Concrete Blocks after 100% Extension – Visual Inspection



Figure 5. Concrete Blocks with Spacer Strips

This brief summarizes of In-House Research Project
“Hot Applied Sealant Bond Test for Joints with Penetrating Sealers”
Nebraska Department of Transportation Research Program