

Date: February 2018

Hot Applied Sealant Bond Test for Joints with Penetrating Sealers

Nebraska Department of Transportation

Research Project: Hot Applied Sealant Bond Test for Joints with Penetrating Sealers

Location: In- House

Project Number: NA

Starting Date: February 2018

Completion Date: February 2018

Principal Investigator:

Lieska Halsey

Assistant Material Engineer

Bituminous Laboratory:

John Gude

Hwy Quality Assurance Manager

Technical Adviser:

Dale Byre

Hwy Materials & Test Manager



Figure 2. Sealer Application



Figure 3. Concrete Blocks on Extension Machine



Figure 4. Concrete Blocks after 100% Extension — Visual Inspection



Figure 5. Concrete Blocks with Spacer Strips

BACKGROUND:

Recently a concern has been raised for hot applied sealant bond for joints with penetrating sealers.

The objective of this study will be to determine if the bond between the sealant and the concrete is compromised by the sealer currently approved to be used in Nebraska. The expected results will be that the bond is not compromised and is serving for the expected joint service life.

DESCRIPTION OF THE STUDY:

1. Evaluate approved penetrating concrete sealers categorized for construction used.
2. Evaluated hot applied sealant bond for joints with penetrating sealers in accordance with ASTM D 5329.

OBJECTIVES

The primary objective of this study is to evaluate the bond performance hot applied sealant bond for joints with penetrating sealers.

SCOPE OF THE LABORATORY TESTING

The three penetrating sealers evaluated are listed below, in accordance with ASTM D 5329:

- Product 1 — 100% active alkyltrialkoxo silane
- Product 2 — 100% active silane
- Product 3 — 100% active silane

The ASTM D 5329 test method covers the testing for hot-applied types of joint sealants and fillers for portland cement concrete. The sealant used for the evaluation was craftco NE- 3405. Three concrete blocks were tested for each sealer evaluated. Figure 1 shows the concrete blocks specimens. Each sealer was applied and let dry for 24 hrs on the concrete surface side of hot sealant application, Figure 2. The maximum heating temperature for the sealant according to the manufacturer recommendation was 400°F. Each product was evaluated with three blocks at 0°F for three cycles called 100% extension at low temperature. At the end of each cycle the specimens are removed from the extension machine, Figure 3. Examined the specimens for obvious separations within the sealant and between the sealant and the blocks, Figure 4. After inspection replace the spacer strips, return to storage at room temperature for 2 h and rest each specimen on one concrete block so that the weight of the top block recompresses the joint sealant, Figure5. Each cycle will follow the same procedure until the end of three cycles.

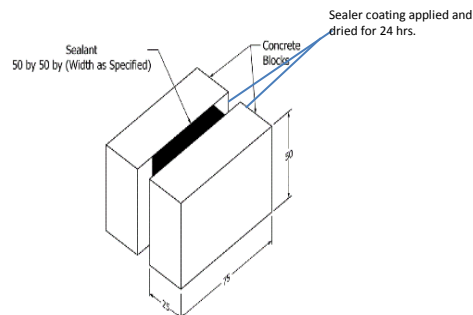

Figure 1. Concrete Block Test Specimen) ASTM D 5329 (1)

LABORATORY RESULTS:

After the completion of 3 cycles for each product evaluated, Table 1. shows the final results for each the bond performance hot applied sealant bond for joints with penetrating sealers.

Designation Name	After 3 Cycles	Cracks/De-bonded > ¼"
Product 1	Pass	None
Product 2	Pass	None
Product 3	Pass	None

CONCLUSIONS AND RECOMENDATIONS:

The Nebraska Department of Transportation occasionally uses concrete sealers to prevent deterioration due to ASR when the pavement does not have the proper mitigation to prevent ASR. The application of sealers as a preventive maintenance tool for pavements will start in 2018. The Department maintains a list of products that are prequalified for use on Nebraska Department of Transportation Construction and Maintenance projects. The hot applied sealant bond for joints with penetrating sealers test will be utilized before the sealer is approved.

REFERENCES

1. Standard Test Methods for Sealants and Fillers, Hot-Applied, for Joints and Cracks in Asphalt Pavements and Portland Cement Concrete Pavements, American Society for Testing and Materials (ASTM) published 2016. Designation D 5329-16