

Construction Manual



2019 Edition

SUMMARY OF TABLE OF CONTENTS

100	Contract Administration & Inspection Procedures
200	Earthwork Inspection Checklists
300	Subgrade Preparation, Foundation Course, Base Course, Shoulder Construction and Aggregate Surfacing
400	Lighting, Signs, and Traffic Signals and Traffic Control
500	Bituminous Pavement
600	Portland Cement Concrete Pavement
700	Bridges, Culverts, and Related Construction
800	Roadside Development and Erosion Control
900	Incidental Construction
1000	Material Details
1100	Environmental
1300	Project Staking

Appendices

Contacts
Construction Directives

Index

101.00	CONSTRUCTION ORGANIZATION	1
101.01	PURPOSE OF MANUAL	1
101.02	ENGINEER'S DUTIES AND AUTHORITY	1
101.03	CONSTRUCTION DIVISION	2
101.04	CHAIN OF COMMAND	2
101.05	STATE CONSTRUCTION ENGINEER	2
101.06	DISTRICT ENGINEER (DE)	3
101.07	DISTRICT CONSTRUCTION ENGINEER (DCE)	3
101.08	PROJECT MANAGER (PM)	4
101.09	CONSTRUCTION TECHNICIAN (CT)	5
102.00	GENERAL RESPONSIBILITIES	6
102.01	PROMPT EXERCISE OF AUTHORITY	6
102.02	APPEALED DECISIONS	6
102.03	INTEGRITY OF EMPLOYEES	7
102.04	PRESENCE ON SITE	8
102.05	PLANS AND WORKING DRAWINGS	8
102.06	PLAN ERRORS/OMISSIONS	8
102.07	PUBLIC RELATIONSHIPS	9
102.08	CONTRACTOR (PARTNERING) RELATIONSHIPS (<i>SSHC Section 113</i>)	11
102.09	FHWA & OTHER OUTSIDE AGENCIES RELATIONSHIPS	11
102.10	EMPLOYMENT OF CONSULTANTS FOR CONSTRUCTION ENGINEERING AND INSPECTION	11
102.11	PERSONNEL	13
102.12	EMPLOYEE POLICIES	13
102.13	STAFF REQUIREMENTS	13
102.14	SUBCONTRACTS	13
102.15	DETOUR REPORT	20
102.16	CONTROL NUMBERS AND CONTRACT NUMBERS	20
102.17	PROJECT DOCUMENTS DISPOSITION	20
103.00	PRECONSTRUCTION	20
103.01	PRECONSTRUCTION CONFERENCE	20
103.02	ADMINISTRATION DETAILS	21
103.03	PROJECT DETAILS	27
103.04	ADDITIONAL TOPICS FOR DISCUSSION	28
103.10	ONE CALL NOTIFICATION	30
103.11	UTILITIES AND RAILROAD REHABILITATION	31
103.12	HAUL ROADS (<i>SSHC Section 107</i>)	32
103.20	CONTRACT ADMINISTRATION	32
103.21	NEBRASKA & FHWA FORMS & REPORTS - PREPARED BY CONTRACTOR	33
103.22	OCCUPATIONAL SAFETY AND HEALTH	34
103.23	EQUAL EMPLOYMENT OPPORTUNITY (EEO)	34
103.24	TRAINING & TRAINEE PROGRAMS	36
103.25	WAGES AND EMPLOYMENT	39
103.26	DAVIS-BACON AND RELATED ACTS REQUIREMENTS (Payrolls)	41
103.27	DISADVANTAGED BUSINESS ENTERPRISE (DBE) SUBCONTRACTOR	45
103.28	LEASE OF PROPERTY BEYOND THE HIGHWAY RIGHT-OF-WAY	49
103.29	CONTRACTOR'S USE OF HIGHWAY RIGHT OF WAY	49
103.30	CONTRACT QUANTITIES	49
103.31	CONTRACTOR'S SALES TAX EXEMPTION	49

103.32	EMAIL – NOTIFICATION	50
103.33	PRIME CONTRACTORS/SUBCONTRACTORS	50
103.40	FREIGHT RATES	50
103.50	BARRICADES, DANGER, WARNING, AND DETOUR SIGNS	50
103.60	SAFETY AND HEALTH REGULATIONS FOR CONSTRUCTION	50
103.61	RESPONSIBILITY OF CONTRACTOR	51
104.00	CONSTRUCTION INSPECTION	51
104.01	CONTRACT TIME DETERMINATION	51
104.02	CHARACTER OF WORKPERSONS, METHODS, AND EQUIPMENT	56
104.03	TEMPORARY SUSPENSION OF WORK	56
104.04	PROGRESS OF WORK	57
104.05	WINTER WORK	58
104.06	WEEKLY REPORT OF WORKING DAYS	58
104.07	RENTAL RATE GUIDELINES	59
104.08	CHANGE ORDER - SUPPLEMENTAL AGREEMENTS (SSHC Subsection 104.02).....	61
104.09	VALUE ENGINEERING	70
104.10	PLANT INSPECTION	72
104.11	PLANT REPORTS	72
104.20	FIELD TESTS	73
104.21	FIELD TESTING ON CONSTRUCTION PROJECTS	73
104.30	TRUCKS/HAULING OF MATERIALS	74
104.40	SCALES	74
104.41	SCALE TICKETS	74
104.42	TRUCK PLATFORM SCALE APPROVAL	75
104.50	SMOOTHNESS	75
104.51	TESTING	75
104.52	EVALUATION	75
104.53	BUMP CORRECTION	76
104.60	LIQUIDATED DAMAGES & EXTENSION OF CONTRACT TIME	76
104.70	ACCIDENTS	77
105.00	MEASUREMENT AND PAYMENT	77
105.01	GENERAL	77
105.02	MEASUREMENT OF QUANTITIES AND COMPENSATION FOR ALTERED QUANTITIES	78
105.03	CANCELLED ITEMS (MATERIALS FURNISHED BY CONTRACTOR AND NOT USED DUE TO CHANGES IN PLANS)	78
105.04	PARTIAL PAYMENT	79
105.05	FIELD MEASUREMENT AND PAYMENT	79
105.06	CONTRACTOR'S ESTIMATES	80
105.07	FIELD COMPUTATIONS FOR FINAL PAYMENT	84
105.08	BORROW AND LOCAL PIT MATERIALS OBTAINED BY THE CONTRACTOR.....	94
105.09	SUMMARY OF FINAL QUANTITIES.....	95
105.10	MOBILIZATION	95
105.11	SALVAGED PROJECT MATERIALS REPORTING	96
106.00	PROJECT FINALIZATION	96
106.01	FINAL PAYMENT TO CONTRACTOR.....	96
106.02	PRICE ADJUSTMENT CHANGE ORDERS	96
106.03	EQUIPMENT PURCHASED BY CONSTRUCTION CONTRACTS	96
106.04	PROJECT ACCEPTANCE AND AUTHORIZATION FOR FINAL PAYMENT	96

106.05	FINAL PACKAGE	97
106.06	FINAL COMPUTATIONS	97
106.07	ACCEPTANCE AND FINAL PAYMENT	97
106.08	FINAL RECORDS	98
106.09	STATEMENT OF MATERIALS AND LABOR	103
106.10	AS-BUILT PLANS	103
106.11	OVERRUNS AND UNDERRUNS LETTER	106
106.12	CONTRACTOR EVALUATIONS	106
106.13	LETTER OF TRANSMITTAL	109
106.14	FINALING PROCEDURES	109
106.15	UNAUTHORIZED WORK	109
106.16	USE OF ADJACENT LAND UNDER CONTRACT OR LEASE	109
106.17	FINAL CLEANING UP	109
106.18	CONSULTANT INSPECTION	110
106.19	PROTEST OF FINAL QUANTITIES OF EARTHWORK ITEMS	110
107.00	LANE RENTAL	111
107.01	INTRODUCTION	111
107.02	HOW LANE RENTAL WORKS	112
107.03	BACKGROUND INFORMATION	112
107.04	CONSTRUCTION COST WITH LANE RENTAL	113
107.05	SAFETY ISSUES	113
107.06	CHANGE ORDERS (ADDED AND DELETED WORK)	113
107.07	PRICING LANE RENTAL BY TIME OF DAY	113
107.08	LANE RENTAL CHARGES	113
200.00	EMBANKMENTS/EXCAVATION CHECKLIST	114
200.01	GENERAL COMMENTS	114
200.02	CRITICAL CONSTRUCTION REQUIREMENTS	123
200.03	SAFETY AREAS	123
200.04	NDOT TESTS	123
200.05	SAMPLING REQUIREMENT/FREQ.	123
200.06	INSPECTOR'S RECORDS & FORMS	124
200.07	NDOT POINT OF CONTACT	124
201.00	GENERAL GRADING INSTRUCTIONS	124
202.00	CLEARING AND GRUBBING	127
202.01	DESCRIPTION	127
202.02	CONSTRUCTION METHODS	127
202.03	METHOD OF MEASUREMENT	129
202.04	BASIS OF PAYMENT	129
203.00	REMOVAL OF STRUCTURES AND OBSTRUCTIONS	130
203.01	DESCRIPTION	130
203.02	CONSTRUCTION METHODS	130
203.03	METHOD OF MEASUREMENT	132
203.04	BASIS OF PAYMENT	132
204.00	TEMPORARY WATER POLLUTION CONTROL	132
204.01	DESCRIPTION	132
204.02	LIMITATION OF OPERATIONS	132
204.03	CONSTRUCTION METHODS	132
204.04	METHOD OF MEASUREMENT	132
204.05	BASIS OF PAYMENT	133
205.00	EXCAVATION AND EMBANKMENT	133

Table of Contents

205.01	DESCRIPTION	133
205.02	MATERIAL REQUIREMENTS	133
205.03	CONSTRUCTION METHODS	135
205.04	METHOD OF MEASUREMENT	139
205.05	BASIS OF PAYMENT	140
206.00	ROADWAY GRADING	140
206.01	DESCRIPTION	140
206.02	MATERIAL REQUIREMENTS	140
206.03	CONSTRUCTION METHODS	140
206.04	METHOD OF MEASUREMENT	140
206.05	BASIS OF PAYMENT	140
207.00	SALVAGING AND PLACING TOPSOIL	140
207.01	DESCRIPTION	140
207.02	MATERIAL REQUIREMENTS	140
207.03	CONSTRUCTION METHODS	140
207.04	METHOD OF MEASUREMENT	140
207.05	BASIS OF PAYMENT	140
208.00	BORROW AND WASTE SITE RESTORATION	141
208.01	DESCRIPTION	141
208.02	CONSTRUCTION METHODS	141
208.03	METHOD OF MEASUREMENT	141
208.04	BASIS OF PAYMENT	141
209.00	OVERHAUL	141
209.01	DESCRIPTION	141
209.02	METHOD OF MEASUREMENT	141
209.03	BASIS OF PAYMENT	141
301.00	GENERAL REQUIREMENTS (See Division 200)	143
302.00	SUBGRADE PREPARATION AND SHOULDER SUBGRADE PREPARATION	143
302.01	DESCRIPTION	143
302.02	MATERIAL REQUIREMENTS	144
302.03	CONSTRUCTION METHODS	144
302.04	METHOD OF MEASUREMENT	145
302.05	BASIS OF PAYMENT	145
303.00	SUBGRADE STABILIZATION	145
303.01	DESCRIPTION	145
303.02	MATERIAL REQUIREMENTS	145
303.03	CONSTRUCTION METHODS	146
303.04	METHOD OF MEASUREMENT	146
303.05	BASIS OF PAYMENT	146
304.00	EARTH SHOULDER CONSTRUCTION	146
304.01	DESCRIPTION	146
304.02	MATERIAL REQUIREMENTS	146
304.03	CONSTRUCTION METHODS	146
304.04	METHOD OF MEASUREMENT	147
304.05	BASIS OF PAYMENT	147
305.00	CRUSHED ROCK BASE COURSE	147
305.01	DESCRIPTION	147
305.02	MATERIAL REQUIREMENTS	148
305.03	CONSTRUCTION METHODS	148
305.04	METHOD OF MEASUREMENT	148

305.05	BASIS OF PAYMENT	148
306.00	GRANULAR FILL	148
306.01	DESCRIPTION	148
306.02	MATERIAL REQUIREMENTS	148
305.03	CONSTRUCTION METHODS	148
306.04	METHOD OF MEASUREMENT	148
306.05	BASIS OF PAYMENT	148
307.00	FOUNDATION COURSE	148
307.01	DESCRIPTION	148
307.02	MATERIAL REQUIREMENTS	149
307.03	CONSTRUCTION METHODS	149
307.04	METHOD OF MEASUREMENT	151
307.05	BASIS OF PAYMENT	151
308.00	MEDIAN CONSTRUCTION	151
308.01	DESCRIPTION	151
308.02	MATERIAL REQUIREMENTS	151
308.03	CONSTRUCTION METHODS	151
308.04	METHOD OF MEASUREMENT	151
308.05	BASIS OF PAYMENT	151
309.00	CALCIUM CHLORIDE TREATMENT	151
309.01	DESCRIPTION	151
309.02	MATERIAL REQUIREMENTS	151
309.03	CONSTRUCTION METHODS	151
309.04	METHOD OF MEASUREMENT	151
309.05	BASIS OF PAYMENT	151
310.00	ROCK OR GRAVEL SURFACING	152
310.01	DESCRIPTION	152
310.02	MATERIAL REQUIREMENTS	152
310.03	CONSTRUCTION METHODS	152
310.04	METHOD OF MEASUREMENT	154
310.05	BASIS OF PAYMENT	154
311.00	FURNISH ROCK OR GRAVEL	154
311.01	DESCRIPTION	154
311.02	MATERIAL REQUIREMENTS	154
311.03	CONSTRUCTION METHODS	154
311.04	METHOD OF MEASUREMENT	154
311.05	BASIS OF PAYMENT	154
312.00	REMOVAL AND PROCESSING OF CONCRETE PAVEMENT	154
312.01	DESCRIPTION	154
312.02	MATERIAL REQUIREMENTS	154
312.03	CONSTRUCTION METHODS	154
312.04	METHOD OF MEASUREMENT	154
312.05	BASIS OF PAYMENT	154
313.00	STABILIZED SUBGRADE TYPE LIME	156
313.01	DESCRIPTION	156
313.02	MATERIAL REQUIREMENTS	156
313.03	CONSTRUCTION METHODS	156
313.04	METHOD OF MEASUREMENT	157
313.05	BASIS OF PAYMENT	157
314.00	STABILIZED SUBGRADE TYPE FLY ASH	157

314.01	DESCRIPTION	157
314.02	MATERIAL REQUIREMENTS	157
314.03	CONSTRUCTION METHODS.....	157
314.04	METHOD OF MEASUREMENT	158
314.05	BASIS OF PAYMENT	158
400.00	CHECKLIST	159
400.01	TRAFFIC SIGNALS	161
400.02	TRAFFIC CONTROL SPECIFICATION REFERENCES	165
400.03	EQUIPMENT AND MATERIAL STORAGE	169
400.04	BRIDGE APPROACH GUARD RAILS	169
400.05	INTERSTATE TRAFFIC CONTROL REQUIREMENTS	170
400.06	DEDUCTION FOR SIGNS	170
400.07	PRECONSTRUCTION CONFERENCE	171
400.08	SHOP DRAWINGS	171
400.09	ACCIDENT REPORTING.....	171
401.00	GENERAL INFORMATION	172
401.01	DESCRIPTION	172
401.02	MATERIAL REQUIREMENTS	172
401.03	TESTS OF LIGHTING SYSTEMS.....	173
401.04	GROUNDING	173
401.05	GENERAL CONSTRUCTION REQUIREMENTS	173
401.06	SECONDARY ELECTRICAL CONNECTIONS	173
402.00	WIRE AND CABLE IN CONDUIT	173
402.01	DESCRIPTION	173
402.02	MATERIAL REQUIREMENTS	173
402.03	CONSTRUCTION METHODS.....	173
402.04	METHOD OF MEASUREMENT	173
402.05	BASIS OF PAYMENT	173
403.00	DIRECT BURIED WIRE AND CABLE	173
403.01	DESCRIPTION	173
403.02	MATERIAL REQUIREMENTS	173
403.03	CONSTRUCTION METHODS.....	173
403.04	METHOD OF MEASUREMENT	173
403.05	BASIS OF PAYMENT	173
404.00	AERIAL CABLE	173
404.01	DESCRIPTION	173
404.02	MATERIAL REQUIREMENTS	173
404.03	CONSTRUCTION METHODS.....	174
404.04	METHOD OF MEASUREMENT	174
404.05	BASIS OF PAYMENT	174
405.00	CONDUIT	174
405.01	DESCRIPTION	174
405.02	MATERIAL REQUIREMENTS	174
405.03	CONSTRUCTION METHODS.....	174
405.04	METHOD OF MEASUREMENT	174
405.05	BASIS OF PAYMENT	174
406.00	PULL BOXES.....	174
406.01	DESCRIPTION	174
406.02	MATERIAL REQUIREMENTS	174
406.03	CONSTRUCTION METHODS.....	174

406.04	METHOD OF MEASUREMENT	174
406.05	BASIS OF PAYMENT	174
407.00	POLE AND TOWER FOUNDATIONS	174
407.01	DESCRIPTION	174
407.02	MATERIAL REQUIREMENTS	174
407.03	CONSTRUCTION METHODS	174
407.04	METHOD OF MEASUREMENT	174
407.05	BASIS OF PAYMENT	174
408.00	POLES AND TOWERS	175
408.01	DESCRIPTION	175
408.02	MATERIAL REQUIREMENTS	175
408.03	CONSTRUCTION METHODS	175
408.04	METHOD OF MEASUREMENT	175
409.00	SIGNAL HEADS	175
409.01	DESCRIPTION	175
409.02	MATERIAL REQUIREMENTS	175
409.03	CONSTRUCTION METHODS	175
409.04	METHOD OF MEASUREMENT	175
409.05	BASIS OF PAYMENT	175
410.00	DETECTORS	175
410.01	DESCRIPTION	175
410.02	MATERIAL REQUIREMENTS	175
410.03	CONSTRUCTION METHODS	175
410.04	METHOD OF MEASUREMENT	175
410.05	BASIS OF PAYMENT	175
411.00	TRAFFIC SIGNAL CONTROLLER	175
411.01	DESCRIPTION	175
411.02	MATERIAL REQUIREMENTS	175
411.03	CONSTRUCTION METHODS	175
411.04	METHOD OF MEASUREMENT	175
411.05	BASIS OF PAYMENT	175
412.00	LUMINAIRES	176
412.01	DESCRIPTION	176
412.02	MATERIAL REQUIREMENTS	176
412.03	CONSTRUCTION METHODS	176
412.04	METHOD OF MEASUREMENT	176
412.05	BASIS OF PAYMENT	176
413.00	LIGHTING CONTROL CENTERS	176
413.01	DESCRIPTION	176
413.02	MATERIAL REQUIREMENTS	176
413.03	CONSTRUCTION METHODS	176
413.04	METHOD OF MEASUREMENT	176
413.05	BASIS OF PAYMENT	176
414.00	HIGH MAST LOWERING SYSTEMS	176
414.01	DESCRIPTION	177
414.02	MATERIAL REQUIREMENTS	177
414.03	CONSTRUCTION METHODS	177
414.04	METHOD OF MEASUREMENT	177
414.05	BASIS OF PAYMENT	177
415.00	MAINTENANCE OF PROJECT LIGHTING SYSTEM	177

415.01	DESCRIPTION	177
415.02	MATERIAL REQUIREMENTS	177
415.03	CONSTRUCTION METHODS	177
415.04	METHOD OF MEASUREMENT	177
415.05	BASIS OF PAYMENT	177
416.00	TEMPORARY LIGHTING SYSTEMS	177
416.01	DESCRIPTION	177
416.02	MATERIAL REQUIREMENTS	177
416.03	CONSTRUCTION METHODS	177
416.04	METHOD OF MEASUREMENT	177
416.05	BASIS OF PAYMENT	177
417.00	HIGHWAY SIGNS	177
417.01	DESCRIPTION	177
417.02	MATERIAL REQUIREMENTS	177
417.03	CONSTRUCTION METHODS	177
417.04	METHOD OF MEASUREMENT	178
417.05	BASIS OF PAYMENT	178
418.00	OVERHEAD SIGN SUPPORTS	178
418.01	DESCRIPTION	178
418.02	MATERIAL REQUIREMENTS	178
418.03	CONSTRUCTION METHODS	178
418.04	METHOD OF MEASUREMENT	178
418.05	BASIS OF PAYMENT	178
419.00	TRAFFIC CONTROL MANAGEMENT AND SURVEILLANCE	178
419.01	DESCRIPTION	178
419.02	CONSTRUCTION METHODS	178
419.03	METHOD OF MEASUREMENT	178
419.04	BASIS OF PAYMENT	178
420.00	DELINEATORS	178
420.01	DESCRIPTION	178
420.02	MATERIAL REQUIREMENTS	178
420.03	CONSTRUCTION METHODS	178
420.04	METHOD OF MEASUREMENT	178
420.05	BASIS OF PAYMENT	178
421.00	REMOVING AND RESETTING DELINEATORS	178
421.01	DESCRIPTION	178
421.02	CONSTRUCTION METHODS	178
421.03	METHOD OF MEASUREMENT	178
421.04	BASIS OF PAYMENT	178
422.00	TEMPORARY TRAFFIC CONTROL SIGNS AND DEVICES	179
422.01	DESCRIPTION	179
422.02	MATERIAL REQUIREMENTS	179
422.03	CONSTRUCTION METHODS	179
422.04	METHOD OF MEASUREMENT	180
422.05	BASIS OF PAYMENT	180
423.00	PERMANENT PAVEMENT MARKING	180
423.01	DESCRIPTION	180
423.02	MATERIAL REQUIREMENTS	180
423.03	CONSTRUCTION METHODS	180
423.04	METHOD OF MEASUREMENT	180

423.05	BASIS OF PAYMENT	180
424.00	TEMPORARY PAVEMENT MARKING	180
424.01	DESCRIPTION	180
424.02	EQUIPMENT	180
424.03	MATERIAL REQUIREMENTS	180
424.04	CONSTRUCTION METHODS	180
424.05	METHOD OF MEASUREMENT	181
424.06	BASIS OF PAYMENT	181
500.00	ASPHALT PAVEMENT CHECKLIST	182
501.00	GENERAL REQUIREMENTS	186
501.01	GENERAL	186
501.02	EQUIPMENT	187
502.00	ASPHALT CONCRETE PAVEMENT SMOOTHNESS	187
501.02	GENERAL	187
502.02	EQUIPMENT	187
502.03	CERTIFICATION AND INDEPENDENT ASSURANCE TESTING	187
502.04	PROFILOGRAPH TEST PROCEDURES	187
502.05	EVALUATION	188
502.06	PAVEMENT SURFACE CORRECTION	188
502.07	TRAFFIC CONTROL	188
502.08	METHOD OF MEASUREMENT	188
502.09	BASIS OF PAYMENT	189
503.00	ASPHALT PAVEMENT	190
503.01	DESCRIPTION	190
503.02	MATERIAL REQUIREMENTS	190
503.03	EQUIPMENT	194
503.04	CONSTRUCTION METHODS	195
503.05	METHOD OF MEASUREMENT	208
503.06	BASIS OF PAYMENT	208
504.00	TACK COAT	209
504.01	DESCRIPTION	209
504.02	MATERIAL REQUIREMENTS	209
504.03	CONSTRUCTION METHODS	210
504.04	METHOD OF MEASUREMENT	210
504.05	BASIS OF PAYMENT	210
505.00	ASPHALTIC CONCRETE CURB	211
505.01	DESCRIPTION	211
505.02	MATERIAL REQUIREMENTS	211
505.03	CONSTRUCTION METHODS	211
505.04	METHOD OF MEASUREMENT	211
505.05	BASIS OF PAYMENT	211
506.00	ASPHALTIC CONCRETE ISLAND NOSES AND MEDIANS	211
506.01	DESCRIPTION	211
506.02	MATERIAL REQUIREMENTS	211
506.03	CONSTRUCTIONS METHODS	211
506.04	METHOD OF MEASUREMENT	212
506.05	BASIS OF PAYMENT	212
507.00	ASPHALTIC CONCRETE FOR STATE MAINTENANCE PATCHING	212
507.01	DESCRIPTION	212
507.02	METHOD OF MEASUREMENT	212

507.03	BASIS OF PAYMENT	212
508.00	JOINT SEALING – ASPHALTIC TO CONCRETE.....	212
508.01	DESCRIPTION	212
508.02	MATERIAL REQUIREMENTS	212
508.03	CONSTRUCTION METHODS.....	212
508.04	METHOD OF MEASUREMENT	213
508.05	BASIS OF PAYMENT	213
509.00	BITUMINOUS SAND BASE COURSE	213
509.01	DESCRIPTION	213
509.02	MATERIAL REQUIREMENTS	213
509.03	EQUIPMENT	213
509.04	CONSTRUCTION METHODS.....	213
509.05	METHOD OF MEASUREMENT	213
509.06	BASIS OF PAYMENT	213
510.00	COLD MILLING.....	214
510.01	DESCRIPTION	214
510.02	MATERIAL REQUIREMENTS	214
510.03	EQUIPMENT	214
510.04	CONSTRUCTION METHODS.....	214
510.05	METHOD OF MEASUREMENT	215
510.06	BASIS OF PAYMENT	215
511.00	SALVAGING AND STOCKPILING BITUMINOUS MATERIAL.....	215
511.01	DESCRIPTION	215
511.02	MATERIAL REQUIREMENTS	215
511.03	EQUIPMENT	215
511.04	CONSTRUCTION METHODS.....	215
511.05	METHOD OF MEASUREMENT	215
511.06	BASIS OF PAYMENT	215
512.00	BITUMINOUS SURFACE COURSE	215
512.01	DESCRIPTION	215
512.02	MATERIAL REQUIREMENTS	215
512.03	CONSTRUCTION METHODS.....	216
512.04	METHOD OF MEASUREMENT	216
512.05	BASIS OF PAYMENT	216
513.00	FOG SEAL	216
513.01	DESCRIPTION	216
513.02	MATERIAL REQUIREMENTS	216
513.02	CONSTRUCTION METHODS.....	216
513.04	METHOD OF MEASUREMENT	217
513.05	BASIS OF PAYMENT	217
514.00	MICROSURFACING	217
514.01	DESCRIPTION	217
514.02	MATERIAL REQUIREMENTS	217
514.03	EQUIPMENT	217
514.04	CALIBRATION METHODS.....	217
514.05	CONSTRUCTION METHODS.....	217
514.06	METHOD OF MEASUREMENT	217
514.07	BASIS OF PAYMENT	218
515.00	ARMOR COAT OR CHIP SEAL	218
515.01	DESCRIPTION	218

515.02	MATERIAL REQUIREMENTS	218
515.03	CONSTRUCTION METHODS.....	218
515.04	METHOD OF MEASUREMENT.....	218
515.05	BASIS OF PAYMENT	218
516.00	BITUMINOUS PAVEMENT PATCHING	219
516.01	DESCRIPTION	219
516.02	MATERIAL REQUIREMENTS	219
516.03	EQUIPMENT	219
516.04	CONSTRUCTION METHODS.....	219
516.05	METHOD OF MEASUREMENT.....	219
516.06	BASIS OF PAYMENT	219
517.00	PRIME COAT	219
517.01	DESCRIPTION	219
517.02	MATERIAL REQUIREMENTS	219
517.03	CONSTRUCTION METHODS.....	219
517.04	METHOD OF MEASUREMENT.....	219
517.05	BASIS OF PAYMENT	219
518.00	FABRIC REINFORCEMENT	219
518.01	DESCRIPTION	219
518.02	MATERIAL REQUIREMENTS	219
518.03	CONSTRUCTION METHODS.....	219
518.04	METHOD OF MEASUREMENT.....	219
518.05	BASIS OF PAYMENT	219
519.00	CRACK SEALING BITUMINOUS SURFACING.....	220
519.01	DESCRIPTION	220
519.02	MATERIAL REQUIREMENTS	220
519.03	CONSTRUCTION METHODS.....	220
519.04	METHOD OF MEASUREMENT.....	220
519.05	BASIS OF PAYMENT	220
520.00	BITUMINOUS PATCHING OF CONCRETE PAVEMENT	220
520.01	DESCRIPTION	220
520.02	MATERIAL REQUIREMENTS	220
520.03	CONSTRUCTION METHODS.....	220
520.04	METHOD OF MEASUREMENT.....	220
520.05	BASIS OF PAYMENT	220
520.06	TARGET VALUES FOR ASPHALTIC CONCRETE PRODUCED	220
600.00	CONCRETE PAVEMENT CHECKLISTS.....	221
601.01	CHECKLISTS	221
600.02	CONCRETE PLANT CHECKLIST.....	223
600.03	CONCRETE PAVEMENT REPAIR CHECKLIST	225
601.00	GENERAL REQUIREMENTS	226
601.01	GENERAL.....	226
601.02	EQUIPMENT	226
602.00	PORTLAND CEMENT CONCRETE PAVEMENT SMOOTHNESS	230
602.01	GENERAL.....	230
602.02	EQUIPMENT	230
602.03	CERTIFICATION AND INDEPENDENT ASSURANCE TESTING	230
602.04	PROFILOGRAPH TEST PROCEDURES	230
602.05	EVALUATION	230
602.06	PAVEMENT SURFACE CORRECTION	230

602.07	TRAFFIC CONTROL	230
602.08	METHOD OF MEASUREMENT	231
602.09	BASIS OF PAYMENT	231
603.00	CONCRETE PAVEMENT	231
603.01	DESCRIPTION	231
603.02	MATERIAL REQUIREMENTS	232
603.03	CONSTRUCTION METHODS	234
603.04	METHOD OF MEASUREMENT	267
603.05	BASIS OF PAYMENT	268
604.00	CONCRETE BASE COURSE	268
604.01	DESCRIPTION	268
604.02	MATERIAL REQUIREMENTS	268
604.03	EQUIPMENT	268
604.04	CONSTRUCTION METHODS	268
604.05	METHOD OF MEASUREMENT	268
604.06	BASIS OF PAYMENT	268
605.00	CONCRETE PAVEMENT REPAIR	268
605.01	DESCRIPTION	268
605.02	MATERIAL REQUIREMENTS	269
605.03	EQUIPMENT	269
605.04	CONSTRUCTION METHODS	269
605.05	METHOD OF MEASUREMENT	269
605.06	BASIS OF PAYMENT	269
606.00	CONCRETE CURB AND CONCRETE GUTTER	270
606.01	DESCRIPTION	270
606.02	MATERIAL REQUIREMENTS	270
606.03	CONSTRUCTION METHODS	270
606.04	METHOD OF MEASUREMENT	270
606.05	BASIS OF PAYMENT	270
607.00	CONCRETE SIDEWALKS, BIKEWAYS, AND MEDIAN SURFACING	270
607.01	DESCRIPTION	270
607.02	MATERIAL REQUIREMENTS	270
607.03	CONSTRUCTION METHODS – ADA REQUIREMENTS	270
607.04	METHOD OF MEASUREMENT	270
607.05	BASIS OF PAYMENT	270
608.00	CONCRETE ISLAND NOSE	270
608.01	DESCRIPTION	270
608.02	MATERIAL REQUIREMENTS	270
608.03	CONSTRUCTION METHODS	270
608.04	METHOD OF MEASUREMENT	270
608.05	BASIS OF PAYMENT	270
609.00	CONCRETE DRIVEWAYS	270
609.01	DESCRIPTION	270
609.02	MATERIAL REQUIREMENTS	270
609.03	CONSTRUCTION METHODS	270
609.04	METHOD OF MEASUREMENT	270
609.05	BASIS OF PAYMENT	270
610.00	CONCRETE MEDIAN BARRIERS	270
610.01	DESCRIPTION	270
610.02	MATERIAL REQUIREMENTS	270

610.03	CONSTRUCTION METHODS.....	270
610.04	METHOD OF MEASUREMENT.....	270
610.05	BASIS OF PAYMENT.....	270
611.00	SEALING TRANSVERSE AND LONGITUDINAL CRACKS.....	270
611.01	DESCRIPTION.....	270
611.02	MATERIAL REQUIREMENTS.....	270
611.03	CONSTRUCTION METHODS.....	271
611.04	METHOD OF MEASUREMENT.....	271
611.05	BASIS OF PAYMENT.....	271
612.00	SEALING TRANSVERSE AND LONGITUDINAL JOINTS.....	271
612.01	DESCRIPTION.....	271
612.02	MATERIAL REQUIREMENTS.....	271
612.03	CONSTRUCTION METHODS.....	271
612.04	METHOD OF MEASUREMENT.....	271
612.05	BASIS OF PAYMENT.....	271
701.00	GENERAL REQUIREMENTS.....	273
701.01	DESCRIPTION.....	273
701.02	GENERAL PROCEDURES.....	273
701.03	EQUIPMENT.....	273
702.00	EXCAVATION FOR STRUCTURES.....	273
702.01	DESCRIPTION.....	273
702.02	MATERIAL REQUIREMENTS.....	273
702.03	CONSTRUCTION METHODS.....	273
702.04	METHOD OF MEASUREMENT.....	277
702.05	BASIS OF PAYMENT.....	277
703.00	PILES AND PILE DRIVING.....	277
703.01	DESCRIPTION.....	277
703.02	MATERIAL REQUIREMENTS.....	282
703.03	EQUIPMENT.....	282
703.04	MATERIAL REQUIREMENTS.....	283
703.05	CONSTRUCTION METHODS.....	283
703.06	METHOD OF MEASUREMENT.....	294
703.07	BASIS OF PAYMENT.....	294
704.00	CONCRETE CONSTRUCTION.....	295
704.01	DESCRIPTION.....	295
704.02	MATERIAL REQUIREMENTS.....	296
704.03	CONSTRUCTION METHOD.....	302
704.04	METHOD OF MEASUREMENT.....	321
704.05	BASIS OF PAYMENT.....	321
705.00	PRECAST/PRESTRESSED CONCRETE STRUCTURAL UNITS.....	321
705.01	DESCRIPTION.....	321
705.02	MATERIAL REQUIREMENTS.....	321
705.03	CONSTRUCTION METHODS.....	321
705.04	METHOD OF MEASUREMENT.....	321
705.05	BASIS OF PAYMENT.....	321
706.00	CONCRETE BRIDGE FLOORS.....	322
706.01	DESCRIPTION.....	322
706.02	MATERIAL REQUIREMENTS.....	323
706.03	CONSTRUCTION METHODS.....	323
706.04	METHOD OF MEASUREMENT.....	335

706.05	BASIS OF PAYMENT	335
707.00	REINFORCEMENT	335
707.01	DESCRIPTION	335
707.02	MATERIAL REQUIREMENTS	335
707.03	CONSTRUCTION METHODS	336
707.04	METHOD OF MEASUREMENT	345
707.05	BASIS OF PAYMENT	345
708.00	STEEL STRUCTURES	345
708.01	DESCRIPTION	345
708.02	MATERIAL REQUIREMENTS	346
708.03	CONSTRUCTION METHODS	346
708.04	METHOD OF MEASUREMENT	361
708.05	BASIS OF PAYMENT	362
709.00	PAINTING	362
709.01	DESCRIPTION	362
709.02	MATERIAL REQUIREMENTS	363
709.03	CONSTRUCTION METHODS	363
709.04	METHOD OF MEASUREMENT	366
709.05	BASIS OF PAYMENT	366
710.00	CONCRETE BRIDGE DECK REPAIR WITH SILICA FUME CONCRETE	366
711.00	CONCRETE BRIDGE DECK REPAIR AND OVERLAY	366
711.01	DESCRIPTION	366
711.02	MATERIAL REQUIREMENTS	367
711.03	EQUIPMENT	368
711.04	CONSTRUCTION METHODS	368
711.05	METHOD OF MEASUREMENT	369
711.06	BASIS OF PAYMENT	370
712.00	FIXED BEARINGS AND EXPANSION BEARINGS, TFE TYPE	370
712.01	DESCRIPTION	370
712.02	MATERIAL REQUIREMENTS	370
712.03	CONSTRUCTION METHODS	370
712.04	METHOD OF MEASUREMENT	370
712.05	BASIS OF PAYMENT	370
713.00	CONFINED ELASTOMERIC BEARING DEVICES (POT BEARINGS)	370
713.01	DESCRIPTION	370
713.02	MATERIAL REQUIREMENTS	370
713.03	CONSTRUCTION METHODS	370
713.04	METHOD OF MEASUREMENT	370
713.05	BASIS OF PAYMENT	370
714.00	MECHANICALLY STABILIZED EARTH (MSE) WALLS WITH CONCRETE FACING PANELS	370
714.01	DESCRIPTION	370
714.02	MATERIAL REQUIREMENTS	370
714.03	CONSTRUCTION METHODS	370
714.04	METHOD OF MEASUREMENT	370
714.05	BASIS OF PAYMENT	370
715.00	MECHANICALLY STABILIZED EARTH (MSE) WALLS WITH MODULAR BLOCK FACING UNITS	370
715.01	DESCRIPTION	370
715.02	MATERIAL REQUIREMENTS	370

715.03	CONSTRUCTION METHODS.....	370
715.04	METHOD OF MEASUREMENT.....	370
715.05	BASIS OF PAYMENT.....	370
716.00	STEEL RAILINGS.....	370
716.01	DESCRIPTION.....	370
716.02	MATERIAL REQUIREMENTS.....	371
716.03	CONSTRUCTION METHODS.....	371
716.04	METHOD OF MEASUREMENT.....	371
716.05	BASIS OF PAYMENT.....	371
717.00	CONCRETE BOX CULVERTS.....	371
717.01	DESCRIPTION.....	371
717.02	MATERIAL REQUIREMENTS.....	371
717.03	CONSTRUCTION METHODS.....	371
717.04	METHOD OF MEASUREMENT AND BASIS OF PAYMENT.....	376
718.00	CULVERT PIPE.....	376
718.01	DESCRIPTION.....	376
718.02	MATERIAL REQUIREMENTS.....	376
718.03	CONSTRUCTION METHODS.....	376
718.04	METHOD OF MEASUREMENT.....	385
718.05	BASIS OF PAYMENT.....	385
719.00	FLEXIBLE PIPE CULVERTS (CORRUGATED METAL AND PLASTIC).....	385
719.01	DESCRIPTION.....	385
719.02	MATERIAL REQUIREMENTS.....	385
719.03	CONSTRUCTION METHODS.....	385
719.04	METHOD OF MEASUREMENT.....	386
719.05	BASIS OF PAYMENT.....	386
720.00	CONCRETE PIPE CULVERTS.....	386
720.01	DESCRIPTION.....	386
720.02	MATERIAL REQUIREMENTS.....	386
720.03	CONSTRUCTION METHODS.....	387
720.04	METHOD OF MEASUREMENT.....	388
720.05	BASIS OF PAYMENT.....	388
721.00	DRIVEWAY CULVERT PIPE.....	388
721.01	DESCRIPTION.....	388
721.02	MATERIAL REQUIREMENTS.....	388
721.03	CONSTRUCTION METHODS.....	388
721.04	METHOD OF MEASUREMENT.....	388
721.05	BASIS OF PAYMENT.....	388
722.00	SEWERS.....	388
722.01	DESCRIPTION.....	388
722.02	MATERIAL REQUIREMENTS.....	388
722.03	CONSTRUCTION METHODS.....	388
722.04	METHOD OF MEASUREMENT.....	388
722.05	BASIS OF PAYMENT.....	388
723.00	TAPPING EXISTING DRAINAGE AND SEWER FACILITIES.....	388
723.01	DESCRIPTION.....	388
723.02	CONSTRUCTION METHODS.....	388
723.03	METHOD OF MEASUREMENT.....	388
723.04	BASIS OF PAYMENT.....	388
724.00	INSTALLATION AND REMOVAL OF FLARED-END SECTIONS.....	388

724.01	DESCRIPTION	388
724.02	MATERIAL REQUIREMENTS	388
724.03	CONSTRUCTION METHODS	388
724.04	METHOD OF MEASUREMENT	388
724.05	BASIS OF PAYMENT	388
725.00	BAR GRATES FOR FLARED-END SECTIONS	388
725.01	DESCRIPTION	388
725.02	MATERIAL REQUIREMENTS	388
725.03	CONSTRUCTION METHODS	388
725.04	METHOD OF MEASUREMENT	388
725.05	DESCRIPTION	388
726.00	CULVERT SANDFILL	389
726.01	DESCRIPTION	389
726.02	MATERIAL REQUIREMENTS	389
726.03	CONSTRUCTION METHODS	389
726.04	METHOD OF MEASUREMENT	389
726.05	BASIS OF PAYMENT	389
727.00	SUBSURFACE DRAINAGE MATTING	389
727.01	DESCRIPTION	389
727.02	MATERIAL REQUIREMENTS	389
727.03	CONSTRUCTION METHODS	389
727.04	METHOD OF MEASUREMENT	389
727.05	BASIS OF PAYMENT	389
728.00	RIPRAP FILTER FABRIC	389
728.01	DESCRIPTION	389
728.02	MATERIAL REQUIREMENTS	389
728.03	CONSTRUCTION METHODS	389
728.04	METHOD OF MEASUREMENT	389
728.05	BASIS OF PAYMENT	389
729.00	DECK JOINT SEALS	389
729.01	DESCRIPTION	389
729.02	MATERIAL REQUIREMENTS	389
729.03	CONSTRUCTION METHODS	389
729.04	METHOD OF MEASUREMENT	389
729.05	BASIS OF PAYMENT	389
730.00	STRIP SEALS	389
730.01	DESCRIPTION	389
730.02	MATERIAL REQUIREMENTS	389
730.02	CONSTRUCTION METHODS	389
730.04	METHOD OF MEASUREMENT	389
730.05	BASIS OF PAYMENT	389
731.00	JACKING CULVERT PIPE, SEWER PIPE, AND CASING	389
731.01	DESCRIPTION	389
731.02	MATERIAL REQUIREMENTS	389
731.03	CONSTRUCTION METHODS	389
731.04	METHOD OF MEASUREMENT	390
731.05	BASIS OF PAYMENT	390
732.00	LEAD-BASED PAINT REMOVAL	390
732.01	DESCRIPTION	390
732.02	MATERIAL REQUIREMENTS	390

732.03	CONSTRUCTION METHODS.....	390
732.04	METHOD OF MEASUREMENT.....	390
732.05	BASIS OF PAYMENT.....	390
733.00	BRIDGE DECK AND APPROACH SLAB SMOOTHNESS.....	390
733.01	DESCRIPTION.....	390
733.02	EQUIPMENT.....	390
733.03	TEST PROCEDURE.....	390
733.04	EVALUATION.....	390
733.05	SURFACE CORRECTION.....	390
733.06	ACCEPTANCE.....	390
734.00	PRECOMPRESSED POLYURETHANE FOAM (PPF) JOINT.....	390
734.01	DESCRIPTION.....	390
734.02	MATERIAL REQUIREMENTS.....	390
734.03	CONSTRUCTION METHODS.....	390
734.04	METHOD OF MEASUREMENT.....	390
734.05	BASIS OF PAYMENT.....	390
735.00	BRIDGE ITEMS.....	390
735.01	BRIDGE DIAPHRAGMS.....	390
735.02	BARRIER RAILS.....	391
735.03	DESCRIPTION.....	391
735.04	MATERIAL REQUIREMENTS.....	392
735.05	CONSTRUCTION METHODS.....	392
800.00	GENERAL COMMENTS.....	394
800.01	REMOVING AND RESETTING TREES CHECKLIST.....	396
801.00	PERMANENT SEEDING.....	404
802.00	COVER CROP SEEDING.....	405
803.00	TEMPORARY SEEDING.....	406
804.00	FERTILIZING.....	407
805.00	SOIL AMENDMENT.....	409
806.00	MULCHING.....	409
807.00	HYDROMULCHING.....	411
808.00	SLOPE PROTECTION.....	411
809.00	SODDING.....	411
810.00	EROSION CONTROL.....	413
811.00	TRANSITION MAT.....	415
812.00	SILT CHECK.....	415
813.00	MULCH PERIMETER CONTROL.....	415
814.00	EARTH AND ROCK CHECKS.....	415
815.00	SILT TRAP.....	415
816.00	SILT FENCE.....	416
817.00	SLOPE TRACKING.....	416
818.00	SOIL ROUGHENING.....	416
819.00	INLET PROTECTION.....	417
820.00	TURBIDITY BARRIER.....	417
821.00	TEMPORARY SLOPE DRAIN.....	417
820.00	DUST CONTROL.....	417
823.00	STABILIZED CONSTRUCTION EXIT.....	418
824.00	CONCRETE WASHOUT.....	418
825.00	FURNISHING AND PLANTING OF PLANT MATERIALS.....	418
901.00	FIELD LABORATORIES AND SCALE HOUSES.....	419

901.01	DESCRIPTION	419
901.02	MATERIAL REQUIREMENTS	419
901.03	CONSTRUCTION METHODS	419
901.04	METHOD OF MEASUREMENT	419
901.05	BASIS OF PAYMENT	419
902.00	GUARDRAIL AND GUARD POSTS	419
902.01	DESCRIPTION	419
902.02	GUARDRAIL CHECKLIST	419
902.03	MATERIAL REQUIREMENTS	420
902.04	CONSTRUCTION METHODS	421
902.05	METHOD OF MEASUREMENT	423
902.06	BASIS OF PAYMENT	423
903.00	INERTIAL BARRIER MODULES	423
903.01	DESCRIPTION	423
903.02	MATERIAL REQUIREMENTS	423
903.03	CONSTRUCTION METHODS	423
903.04	METHOD OF MEASUREMENT	423
903.05	BASIS OF PAYMENT	424
904.00	ROCK RIPRAP	424
904.01	DESCRIPTION	424
904.02	MATERIAL REQUIREMENTS	424
904.03	CONSTRUCTION METHODS	424
904.04	METHOD OF MEASUREMENT	424
904.05	BASIS OF PAYMENT	424
905.00	BROKEN CONCRETE RIPRAP	424
905.01	DESCRIPTION	424
905.02	MATERIAL REQUIREMENTS	424
905.03	CONSTRUCTION METHODS	424
905.05	BASIS OF PAYMENT	424
906.00	GABIONS AND REVET MATTRESSES	424
906.01	DESCRIPTION	424
906.02	MATERIAL REQUIREMENT	424
906.03	CONSTRUCTION METHODS	424
906.04	METHOD OF MEASUREMENT	424
906.05	BASIS OF PAYMENT	424
907.00	CONCRETE SLOPE PROTECTION, DITCH LINING, FLUMES AND DISCHARGE STRUCTURES	425
907.01	DESCRIPTION	425
907.02	MATERIAL REQUIREMENTS	425
907.03	CONSTRUCTION METHODS	425
907.04	METHOD OF MEASUREMENT	425
907.05	BASIS OF PAYMENT	425
908.00	INSTALLING TIE BARS	425
908.01	DESCRIPTION	425
908.02	MATERIAL REQUIREMENTS	425
908.03	CONSTRUCTION METHODS	425
908.04	METHOD OF MEASUREMENT	425
908.05	BASIS OF PAYMENT	425
909.00	RIGHT-OF-WAY AND BARBED WIRE FENCE	425
909.01	DESCRIPTION	425

909.01	MATERIAL REQUIREMENTS	425
909.03	CONSTRUCTION METHODS	425
909.04	METHOD OF MEASUREMENT	425
909.05	BASIS OF PAYMENT	425
910.00	CHAIN-LINK FENCE	426
910.01	DESCRIPTION	426
910.02	MATERIAL REQUIREMENTS	426
910.03	CONSTRUCTION METHODS	426
910.04	METHOD OF MEASUREMENT	426
910.05	BASIS OF PAYMENT	426
911.00	SPECIAL SURFACE COURSE FOR MAILBOX TURNOUTS	426
911.01	DESCRIPTION	426
911.02	MATERIAL REQUIREMENTS	426
911.03	CONSTRUCTION METHODS	426
911.04	METHOD OF MEASUREMENT	426
911.05	BASIS OF PAYMENT	426
912.00	RIGHT-OF-WAY MARKERS	426
912.01	DESCRIPTION	426
912.02	MATERIAL REQUIREMENTS	426
912.03	CONSTRUCTION METHODS	426
912.04	METHOD OF MEASUREMENT	426
912.05	BASIS OF PAYMENT	426
913.00	SUBDRAIN EARTHWORK	426
913.01	SUBDRAINS	426
913.02	BACKSLOPE DRAINS	426
913.03	LONGITUDINAL DRAINS	427
914.00	GRANULAR SUBDRAINS	427
914.01	DESCRIPTION	427
914.02	MATERIAL REQUIREMENTS	427
914.03	CONSTRUCTION METHODS	427
914.04	METHOD OF MEASUREMENT	428
914.05	BASIS OF PAYMENT	428
915.00	CATCH BASINS, MANHOLES, INLETS, AND JUNCTION BOXES	428
915.01	DESCRIPTION	428
915.02	MATERIAL REQUIREMENTS	428
915.03	CONSTRUCTION METHODS	428
915.04	METHOD OF MEASUREMENT	428
915.05	BASIS OF PAYMENT	428
916.00	RECONSTRUCTION OF MANHOLES AND ADJUSTING MANHOLES TO GRADE	428
916.01	DESCRIPTION	428
916.02	MATERIAL REQUIREMENTS	428
916.03	CONSTRUCTION METHODS	428
916.04	METHOD OF MEASUREMENT	428
916.05	BASIS OF PAYMENT	428
917.00	ABANDONING MANHOLES, INLETS, AND JUNCTION BOXES	428
917.01	DESCRIPTION	428
917.02	MATERIAL REQUIREMENTS	428
917.03	CONSTRUCTION METHODS	428
917.04	METHOD OF MEASUREMENT	429
917.05	BASIS OF PAYMENT	429

918.00	EQUIPMENT RENTAL	429
918.01	DESCRIPTION	429
918.02	EQUIPMENT REQUIREMENTS	429
918.03	CONSTRUCTION METHODS	429
918.04	METHOD OF MEASUREMENT	429
918.05	BASIS OF PAYMENT	429
919.00	DAMPPROOFING	429
919.01	DESCRIPTION	429
919.02	MATERIAL REQUIREMENTS	429
919.03	CONSTRUCTION METHODS	429
919.04	METHOD OF MEASUREMENT	429
919.05	BASIS OF PAYMENT	429
920.00	MAILBOX POSTS	429
920.01	DESCRIPTION	429
920.02	MATERIAL REQUIREMENTS	429
920.03	CONSTRUCTION METHODS	429
920.04	METHOD OF MEASUREMENT	429
920.05	BASIS OF PAYMENT	429
1001.00	GENERAL	430
1001.01	SILENCE WITHIN THE SPECIFICATION	430
1001.02	MATERIAL INADVERTENTLY INCORPORATED	430
1001.03	SAMPLE RECORD	430
1001.04	VISUAL ACCEPTANCE BY THE ENGINEER	431
1001.05	CERTIFICATE OF COMPLIANCE	431
1001.06	CERTIFICATE OF TESTS	431
1001.07	APPROVED PRODUCTS LIST	431
1001.08	SAMPLING/TEST	431
1002.00	MATERIAL CERTIFICATION RECEIPT & INTEREST DATE DETERMINATION	431
1003.00	APPROVED PRODUCTS LIST	432
1003.01	DESCRIPTION	432
1003.02	ACCESS COMMANDS	432
1003.03	ADDITIONS/DELETIONS TO THE APPROVED PRODUCTS LIST	432
1004.00	WHITE PIGMENTED CURING COMPOUND AND HOT-POUR JOINT SEALER	432
1004.01	DESCRIPTION	432
1004.02	REPORTING MATERIAL USAGE	432
1005.00	PCC REQUIREMENTS	433
1005.01	CEMENT CERTIFICATIONS	433
1005.02	CONCRETE STRENGTH	433
1005.03	CONCRETE CYLINDER POLICY	433
1006.00	MATERIAL & RESEARCH DIVISION'S FINAL REVIEW PROCEDURES	434
1100.00	ENVIRONMENTAL	435
1100.01	INTRODUCTION	435
1100.02	ARMY CORPS 404 PERMITS	436
1100.03	WETLANDS	436
1100.04	WASTED GENERATED	436
1100.05	CLEAN AIR ACT	437
1100.06	WATER WELLS	437
1100.07	ARCHEOLOGICAL AND PALENTOLOGICAL DISCOVERIES	437
1100.08	UNDERGROUND TANKS	437
1100.09	STORM WATER DISCHARGE	439

Table of Contents

1100.10	BRIDGE PAINTING	439
1100.11	ASBESTOS	439
1100.12	LIGHT BULBS, THERMOSTATS, & BALLASTS	439
1100.13	SURFACE WATER.....	439
1100.14	PROTECTION OF HISTORIC STRUCTURES	439
1100.15	ENCOUNTERING HUMAN REMAINS	440
1300.00	PROJECT STAKING	441
1300.01	GENERAL.....	441
1300.02	CONSTRUCTION STAKES.....	444
1300.03	CONSTRUCTION SURVEY BASIC REQUIREMENTS	450
1300.04	TAKING PRECONSTRUCTION CROSS SECTIONS	470
1300.05	FINAL CROSS SECTIONS AND FINAL QUANTITIES	472
1300.06	CONTRACTOR FURNISHED CONSTRUCTION SURVEY	475
1300.07	ENGINEERING EQUIPMENT, SUPPLIES AND SERVICES	476

DIVISION 100

CONTRACT ADMINISTRATION & INSPECTION PROCEDURES

DIVISION 100
CONTRACT ADMINISTRATION & INSPECTION PROCEDURES

101.00 CONSTRUCTION ORGANIZATION

101.01 PURPOSE OF MANUAL

- Establish uniform policies and procedures for contract administration and inspection of construction projects, and provide interpretation and clarification of specifications.
- Serve as a collecting point for new instructions and guidelines relating to administration and inspection of construction projects.
- Describe the role of District Engineers, District Construction Engineers, Project Managers, Construction Technicians, and others assigned to supervise and inspect construction projects.

101.02 ENGINEER'S DUTIES AND AUTHORITY

1. Authority of the Director

- a. General - The specifications are the Engineer's authority to decide questions as to quality or acceptability of material furnished, work performed, manner of performance, rate of progress of the work, and interpretations of the plans and specifications.

The authority exercised by the Engineer as provided in *SSHC Subsection 104.02 and Subsection 105.01* includes the following:

- (i) Authority to enforce specific requirements and provisions of the plans and specifications.
- (ii) Authority to interpret the requirements and provisions of the plans and specifications.
- (iii) Authority to authorize (approve) revisions or modifications in the contract or to authorize or establish new or additional plans or specifications.
- (iv) Authority to suspend all or part of the work under certain conditions.

b. Delegation of Authority

General - The Director, exercising the responsibilities given him/her by the statutes regarding the control, management, supervision, administration, and direction of the Department of Transportation, assigns and designates to various engineering, management, and technical personnel the responsibility for the performance of certain functions of the highway construction operations.

The assignment and designation of responsibility for the performance, supervision, or completion of any task by this Highway Construction Manual also includes the authority necessary to complete that task.

101.03 CONSTRUCTION DIVISION

The Construction Division is the eventual authority for all your unresolved contract and construction related questions. It provides:

- Direction and consultation to District Engineers, Construction Engineers, Project Managers, Construction Technicians, and central office staff relating to specifications, methods, techniques, and policies on highway construction, inspection, and contract award and administration.
- Final decision capability for all disputes or questions regarding contract administration.

The State Construction Engineer is directly accountable to the Deputy Director for Operations.

Responsibility for administering construction contracts on the roads, highways, and interstate systems rests with the State Construction Engineer. Responsibility for actual construction work is delegated to the District Engineer and ultimately rests with the Project Manager.

101.04 CHAIN OF COMMAND

The normal chain of command for questions and business operations is as follows:

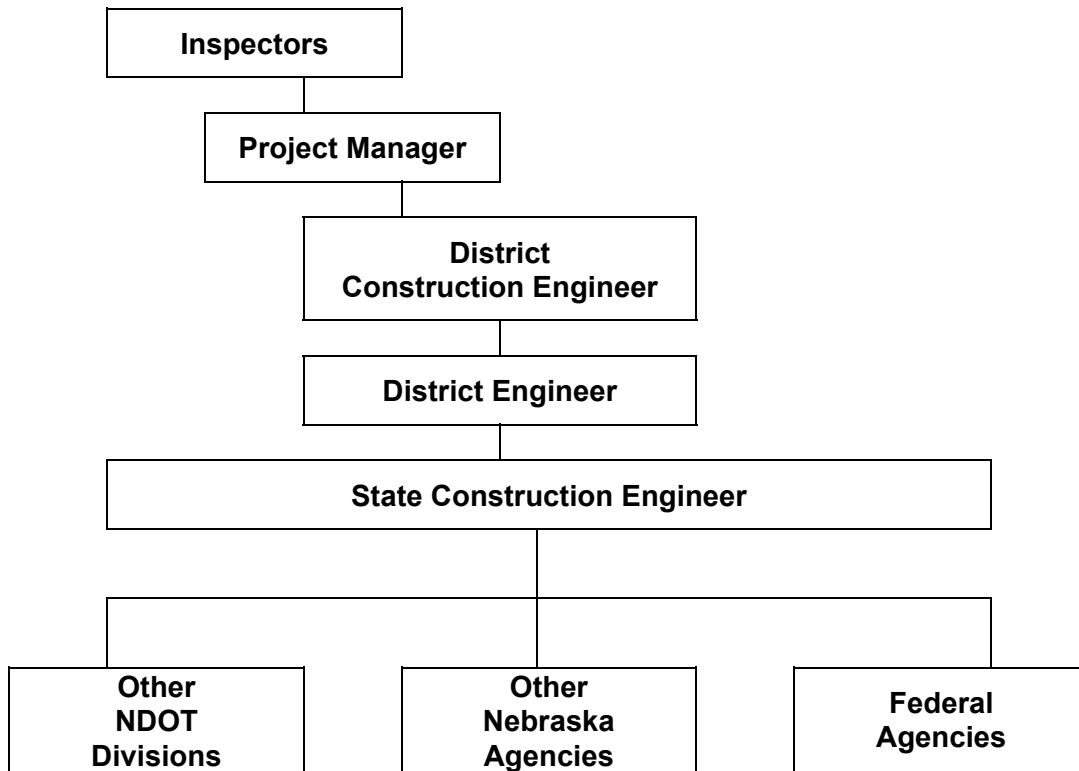

101.05 STATE CONSTRUCTION ENGINEER

The State Construction Engineer provides guidance to District Construction Offices to insure compliance with Specifications and established policies and procedures in the timely completion of NDOT projects. The District Engineer, through the Project Manager, has direct responsibility for construction projects. The State Construction Engineer is the

next level of authority on approval of substantial change orders and the resolution of contract disputes when District Engineer decisions are appealed.

Interpretation of Specifications

The Construction Division provides consultation and advice on construction problems concerning the application and interpretation of Specifications and other contract requirements. Providing this guidance on a statewide basis is intended to insure uniform and fair contract administration.

101.06 DISTRICT ENGINEER (DE)

1. The District Engineer is responsible to the Director for the proper administration and completion of each contract for highway construction in their District.

The District Engineer has the responsibility and the authority to:

- a. Manage the field staff that provides construction and materials inspection on highway projects within each NDOT District. This responsibility includes oversight on contract administration issues, compliance of materials, quality of work performed, and approval of most change orders.
- b. Enforce specific requirements of the plans and specifications in the completion of contracts for highway work. (Generally, he/she will actually delegate this responsibility and authority to the Project Manager.)
- c. Interpret or rule on disputes over requirements of the plans and specifications and decide questions which may arise in all cases when such interpretations and decisions will result in completion of the work in accordance with the intent of the plans and specifications.
- d. Prepare and recommend revisions and modifications in the requirements or provisions in the plans or specifications, or prepare and recommend additional requirements in cases where construction conditions appear to warrant revisions or additional requirements. See *SSHC Subsection 104.02* for alterations which can be approved by the District Engineer.
- e. Delegate the direct responsibility for the engineering supervision and inspection at the project level, generally through the District Construction Engineer to Project Managers in the field.

DEs also provide field input into construction related problems for process improvements. It is imperative that DEs maintain a close working relationship with all central offices.

101.07 DISTRICT CONSTRUCTION ENGINEER (DCE)

The DCE is responsible for management of the field staff that provides construction and materials inspection on highway projects within each NDOT District. This responsibility includes oversight on contract administration issues, compliance of materials, quality of work performed, and approval of most change orders. DCEs also provide field input into construction related problems for process improvements. It is imperative that DCEs maintain a close working relationship with all central offices. The DCEs report to the DE.

The District Construction Engineer is responsible directly to the District Engineer for the direct and close supervision of the construction work and the supervision of Project Managers at the project level, as assigned to him/her by the District Engineer. The

District Construction Engineer has the same authority as listed for the District Engineer when carrying out and discharging the responsibilities assigned to him/her by the District Engineer.

101.08 PROJECT MANAGER (PM)

The Project Manager, working directly under the supervision of the District Construction Engineer (DCE), is responsible through the DCE to the District Engineer for the construction of the project in accordance with the requirements of the plans and specifications. The Project Manager is responsible for and has the authority to assign or delegate the supervision, staking, or inspection of construction work phases or operations to engineers or construction technicians working under their direction.

The Project Manager is the key person in the field organization. The Project Manager's diligence, knowledge, and integrity are important in carrying out the work of planners and designers. The assignment demands judgment, courage, ingenuity, foresight, and tact. Its reward includes priceless experience in the arts of supervision, organization, engineering, and public relations. It also furnishes pride and satisfaction in a job well done.

In assuming the responsibility for proper fulfillment of assigned construction work, the Project Manager is also accountable for:

- Maintaining professional relationships with contractors, affected property owners, and the general public.
- Assigning personnel to inspection and survey operations on the project, along with providing the supervision and instructions necessary to assure proper performance of assigned duties.
- Keeping the District and Headquarters Office informed as to construction progress, status, etc.
- Maintaining a complete record and proper documentation of all quantities and transactions relative to the project.
- Assuring proper use of equipment and materials used in the performance of assigned duties.

While Project Managers have responsibility for general supervision of the work, their main concerns are safety, compliance with specifications and project completion. It is not their responsibility to direct the everyday activities of the contractor, and they should not do so.

The Project Manager is authorized to assign or delegate the inspection and record keeping required for the project. The Project Manager must monitor the delegated tasks to insure they are being properly performed.

In cases of questionable application of plan or specification requirements, the Project Manager may decide such questions or make interpretation of specification requirements if the decision or interpretation will clearly result in the completion of the work in accordance with the intent of the plans and specifications.

If the intent of the plans or specifications is not clear or a dispute over interpretation of plan or specification requirements develops, or if the provisions are clearly unworkable or impractical, the Project Manager shall submit the question or problem to the District Construction Engineer or District Engineer for determination.

If an immediate decision must be made, or question resolved, and the District Engineer or the District Construction Engineer is not available, the Project Manager is authorized to contact and consult the State Construction Engineer or the appropriate Assistant Construction Engineer who will, if required, contact the appropriate division engineer concerned (Design, Bridge, Materials and Research, or Right of Way) for a determination. Exceptions to the foregoing are questions considered routine in nature concerning materials, in which case the Materials and Research Division may be contacted directly.

Delegation of Responsibility

The Project Manager cannot and should not expect to retain all the duties and responsibilities assigned. In an efficient organization, each employee should be delegated authority in line with their responsibilities and duties. The Project Manager must check to see that duties delegated to the Construction Technicians are properly performed.

Responsibility for inspection and surveying on a project should be delegated to one or more experienced employees. This includes the responsibility for documentation of quantities and administrative work necessary for preparation of the final estimate. Inspectors must have authority to direct and coordinate activities of inspection or survey personnel assigned to them.

All employees should be encouraged to accept delegated responsibility and to make decisions within the authority delegated to them.

101.09 CONSTRUCTION TECHNICIAN (CT)

Construction Technician must review and understand the Plans, Special Provisions, Specifications, utility agreements, railroad agreements, and municipal/county agreements. A CT will be assigned to monitor or inspect specific construction operations by the Project Manager. The CT will be responsible for and directly accountable to the Project Manager for the proper performance of the task assigned.

The CT has the authority to inspect all work performed and materials furnished and to enforce all specific requirements of the plans and specifications involved in the operations to which he/she is assigned.

In cases of questionable application of plan or specification requirements to the work in progress, and if an immediate decision is needed, the CT should, if the CT judges the intent of the requirement to clearly warrant a reasonable interpretation, make such an interpretation. The CT should, when time permits, initially take such matters to the Project Manager for interpretation. If an immediate decision is necessary and is made by the inspector, the CT should have the Project Manager review and confirm the decision or interpretation at the earliest opportunity.

If the intent of the plans or specifications is not clear, or if the provisions are unworkable, the CT shall consult the Project Manager.

102.00 GENERAL RESPONSIBILITIES

102.01 PROMPT EXERCISE OF AUTHORITY

The contractor is entitled to timely decisions and notice as to acceptability or failure of the work or materials to conform to specified requirements.

Construction staff should understand their duties, responsibility for the performance of the assignment, the authority of the assignment, and the authority to carry out the responsibility.

Making decisions is exercising authority. Decisions as to the acceptability or failure of work or materials should be made promptly and as near to the actual site of the work as possible. Accordingly, the large proportion of decisions and the greatest exercise of authority will be made by the inspector and the Project Manager at the site of the work. These engineering personnel are on the site of the work in actual contact with the work operation and with the contractor. If the work is not being performed or produced to meet the specified requirements, they have the responsibility and the authority to revise the contract or reject the material, suspend the improper operation, or take remedial or corrective measures.

102.02 APPEALED DECISIONS

Authority exercised will sometimes be questioned by an appeal of the decision or interpretation which was made. This procedure can be expected in the case of:

1. Decisions made or instructions given which are contrary to or inconsistent with the plans or specifications.

Obviously, decisions should not be made or instructions should not be given which are contrary to design requirements, the plans, or the Specifications. However, through lack of knowledge, inadvertence, or complication of application of the proper requirements, such decisions or instructions are sometimes made.

In such cases, the decision or instruction should be rectified, whether by appeal or otherwise, and without prejudice.

2. Decisions made in cases of conflicting plan or specification requirements or interpretation made in the case of questionable application of plan or specification requirements.

It will be realized that in cases of conflicting requirements or questionable application of plan or specification requirements, the decision or interpretation must be made on the basis of engineering analysis and judgment, precedent, or policies previously established. In most cases, the engineer at the site of work will be able to make a decision which will be supported by these factors. However, in a few cases he/she may make a decision based on a limited knowledge of the factors involved. Appeal of the decision may show that additional factors or elements which were not known to the Project Manager may make it necessary to overrule the original decision. This situation can be compared to appeals of court decisions to higher courts where additional study and comparison of preceding cases will sometimes result in reversed decisions. Accordingly, an engineer making decisions or giving instructions in the case of plan or specification requirements of questionable intent or application may occasionally have such decisions or instructions appealed, overruled, or reversed. The engineer should understand, however, that when such decisions are necessary, they are made without prejudice to himself/herself or to the other parties involved.

102.03 INTEGRITY OF EMPLOYEES

Complete integrity on the part of all government employees is essential. Integrity is defined as "moral soundness; honesty; uprightness".

The wide national publicity given to the few inefficient or dishonest employees discovered in the selected investigations, audits, and inspections make it necessary to officially recognize and emphasize that complete integrity is an essential and required qualification. It is also considered necessary to direct the attention of all our engineering employees to the "conflict of interest" statutes, listing specific items which may be prohibited by such statutes or which are incompatible with complete integrity.

Examples of serious conflict of interest acts which are forbidden:

- a. Solicitation or acceptance of a cash loan or a gift of value from any contractor, contractor's representative, or contractor's material supplier doing business with the Department.
- b. Performing engineering work or services for, or receiving compensation for such work or services from, any contractor, contractor's representative, or contractor's material supplier doing business with the department.
- c. The Project Manager and all inspectors shall report to the District Engineer any salvage materials that will be required to be removed from the limits of the project but are not indicated on the plans. This may include, but not be limited to, such items as: trees, fence, fence posts, structures, crops, or any other item that may or may not appear to have value. These materials are the property of the state and cannot be removed and disposed of for personal gain.

The "conflict of interest" portion of the Code of Federal Regulations 23 CFR §1.33 revised April 1, 2015 reads in part as follows:

"No engineer, inspector, or other person performing services for a state or a governmental instrumentality in connection with a project shall have, directly or indirectly, a financial or other personal interest, other than their employment or retention by a State or other governmental instrumentality, in any contract or subcontract in connection with such project."

All contracts for construction on Federal-Aid highway projects include a statement in the contract Special Provisions called:

"FALSE STATEMENTS CONCERNING HIGHWAY PROJECTS"

This provision says the contractor, Project Manager, inspectors, and all others can be fined or imprisoned not more than five years, or both, for making false statements.

The Project Manager and inspector should realize that as an employee of the public, their conduct must be exemplary and merit the full confidence and appreciation of the public. Accordingly, he/she should avoid conduct or acts which may seem harmless, but which could be misinterpreted or appear questionable. Examples of conduct that could possibly be classified as incompatible with complete integrity are:

- a. Excessive fraternization between the Project Manager (PM) or Construction Technicians (Inspectors) and the contractor or their supervisory personnel;
- b. Excessive fraternization between the PM or CT and the contractor's material supplier or material promoter.

It is essential that all PMs and CTs be familiar with these requirements and comply with the specific requirements of the regulations and statutes and conduct themselves with complete integrity.

Removing Materials from Projects

NDOT personnel are not allowed to remove any construction related materials from a project during or after work hours for any reason other than official sampling and testing. Such actions could be misconstrued by the public as accepting favors from a contractor or private use of public property.

Construction materials are defined as, but not limited to, pile cut-offs, old plywood, broken tools, piles of aggregate, erosion control materials and plantings, concrete test beams, samples of aggregates or other materials, and the products of project site clearance.

Complete cleanup of the construction area or plant site, including test materials, is the responsibility of the contractor.

102.04 PRESENCE ON SITE

As the Department's representative on the project, it is essential that the Project Manager be available at all times to the contractor, their subordinates, and the supervisor. The PM should never be absent from the job without their whereabouts being known to someone, so that he/she may be contacted if necessary. The Project Manager's absence from the project will certainly compromise their efficiency and can be most embarrassing to their superiors.

102.05 PLANS AND WORKING DRAWINGS (SSHC 105.02)

"All authorized alterations affecting the requirements and information given in the approved plans shall be in writing". Such alterations will generally be authorized by revised plans, and the Project Manager should only authorize alterations on that basis.

102.06 PLAN ERRORS/OMISSIONS

The Project Manager, upon discovering or suspecting an error or omission in the plans, will immediately send an e-mail note to the District Construction Engineer and, if directed, to the Construction Division in Lincoln. The note should provide all available information. This would include:

- A description of the problem and reasons for concluding a plan error or omission.
- The sheet number(s) where the error is located.

- What alternatives are available.

The Construction Division will contact the design Section Head responsible for the work where the error or omission is suspected and determine if a problem exists.

- For consultant designed plans, the design Section Head must notify the consultant and Project Development's Agreement Engineer if a problem with the plans exist.
- The consultant must be included immediately in the discussion and resolution of the problem. They may have a workable and less costly solution.

The final solution to the error or omission will be an agreed joint decision by the Construction Division, the District, and the responsible design Section Head, and the consultant (when applicable).

For consultant designed plans, the District must send the Agreements Engineer a signed copy of the "Contractor Change Order/Supplemental Agreement."

102.07 PUBLIC RELATIONSHIPS

General Project Supervision

The PM should have the correct crew for each job.

Meeting the public with courtesy is always possible and will usually encourage a willingness to cooperate. The general public will exhibit a natural interest in work performed by or under the supervision of the Department of Transportation, and employees should carefully refrain from making any unauthorized interpretation of policy or careless comment concerning the organization and its policies.

Project Managers and inspectors are among the most important individuals in development of good public relations. Located throughout the state, they can contribute toward a better understanding of the highway program and construction operations by volunteering to appear before local civic organizations. Acquainting the public with interesting details of highway construction is a proactive approach and usually avoids or diffuses criticism.

Residents Along Construction Projects

Project Managers and their staffs and the contractor's representative should contact residents and businesses along the roads that will be under construction. Before work is started, an effort should be made to advise these people of upcoming construction and discuss the probable effect on their operations. This gives them an opportunity to arrange their operations to fit the construction schedule. Both the Project Managers and the contractors have a large interest in promoting local goodwill. Construction schedules can always be arranged so that the least inconvenience will result to local residents and businesses.

Highway construction operations can cause a major change in daily traffic patterns of residents and business people. Most have no conception of road construction problems but accept some inconvenience for the welcomed improvement.

Occasionally, Project Managers may encounter individuals that are critical of the construction inconvenience. Their viewpoint must be understood to deal patiently with their demands and criticisms. Give these individuals a chance to state the problem. Sincere and courteous consideration could avoid development of ill feeling and anger.

Services Relationships

Many services such as mail delivery, school buses, fire protection, etc., may require special attention. People in charge of these services should be advised of upcoming construction and, where possible, arrangements made to provide a detour or access across or through the project for services that must be continued during construction.

News Media Relationships

Consult the Communications and Public Policy Division's [Media Guidelines Manual](#) before making any public comments.

Good relations with news media can help develop and maintain good public relations. When time permits, always contact the Communications and Public Policy Division before going on the record. While reporters may have very little knowledge of road construction, they are well known by local residents and could have a big influence on attitudes of people living along or otherwise affected by the construction project.

News media contacts should be professional and positive to maintain a good public image for the Department.

RULE #1: Never criticize another NDOT division or employee in public (i.e., Don't say the design was bad.)

The Project Manager represents a public agency spending public money and is not entitled to withhold information from the public press. The Freedom of Information Act opens most of our files to public scrutiny. Sensitive material should be cleared with the NDOT Assistant Attorney General prior to release to the public or outside attorneys.

Information should always be presented in as favorable and factual form as possible.

Project Managers should confine remarks to those areas over which they have personal control. Any questions directed toward NDOT policies or public criticism of their superiors should be politely turned aside.

Relations with Cities and Counties

Cost overruns on projects where other governmental entities (cities or counties) bear a portion of the cost, particularly County Federal-Aid Secondary projects, can cause an unexpected financial burden for that governmental entity. On past occasions these situations have provoked feelings of ill will against the Department of Transportation when the governmental entity was billed for the unexpected overrun of costs for which they had not budgeted.

Accordingly, the Project Manager should maintain a watchful eye for this particular situation and, if it becomes apparent that a significant overrun in engineering or construction costs will occur, notify the governmental entity in writing of the approximate amount of overrun.

When consultant engineering is used, the State's representative needs to insure that the Federal/State aid is being properly spent. Any doubts or problems should be discussed with the consultant/county's Project Manager. If it cannot be resolved at this level, a letter detailing the problem must be sent to the chairman of the county board or village/city council.

102.08 CONTRACTOR (PARTNERING) RELATIONSHIPS (SSHC Section 113)

Under the contract system used in highway construction, contractors aim to perform the work contracted and NDOT Engineers see that the work performed is done according to project plans and Specifications. Since these aims are essentially the same, Engineer-contractor relations should be conducted in a spirit of mutual cooperation within the framework of the Specifications and with the best interest of both contracting parties. Establishing a cooperative and collaborative working relationship with contractors may result in improved quality and fewer unresolved contract issues. This is the goal of "Partnering."

Contractors should do no less than required by contract, nor should they expect compensation for work done that was not required.

Good contractor relations can be promoted by keeping an open line of communication and advising contractors when they are doing unacceptable work before such work is completed.

- Good Project Managers know how the contractor should construct the project. They go out of their way to make sure the contractor starts each phase of construction using proper methods and the correct materials.
- It is 1,000 times easier to correct a subgrade problem with the grading crew than with the paving crew.

The most common construction problem is the contractor being notified after the fact that the work was not done according to the Specifications.

In general, relations with the contractor should be fair, firm, courteous, and based on sound judgment under the guidance of specification requirements.

102.09 FHWA & OTHER OUTSIDE AGENCIES RELATIONSHIPS

FHWA has oversight authority only. FHWA representatives have the right to examine any phase of work, including methods of tests, project records, material reports, etc., to review performance of State inspection personnel assigned to the project, and to check work for compliance with plans and specifications. Their responsibility or authority does not extend to supervising or directing Project Managers or contractor forces.

Reports covering their inspections are forwarded to the Construction Division and then are made available to the District Engineer and Project Manager.

Relations with FHWA personnel should be conducted in a spirit of cooperation and courtesy, extending any assistance or facilities available. The FHWA Engineer should be informed of anticipated plan changes or extra work, on all Projects of Division Interest (PODI) that are on the National Highway System.

Inquiries from other state or government agencies should be given prompt and courteous consideration.

102.10 EMPLOYMENT OF CONSULTANTS FOR CONSTRUCTION ENGINEERING AND INSPECTION

From time to time, and with increasing frequency, various governing bodies hire consultant services. Governing bodies could be cities, counties, or the State.

Agreement Responsibilities

Responsibilities of a consultant may be limited to providing professional advice to the governing body on the best means of satisfactorily accomplishing the work or may include specific project level engineering or inspection responsibilities. These guidelines will address engineering or inspection responsibilities. The consultant's contract should define respective authorities and responsibilities of the full-time publicly employed project administrator in charge of the project and consultant's staff.

Under federal-aid regulations, however, prime responsibility for general supervision of construction remains with the governing body. The state (county or city under agreement with state) cannot be relieved of its responsibility to insure that work is performed in accordance with project plans and specifications, even when we hire a consultant to do the inspection or design.

Project Manager

When a consultant has been engaged to provide engineering and inspection services, a Project Manager designated by the Department should also maintain working knowledge of the project.

The designated Project Manager is responsible for being thoroughly knowledgeable of day-to-day operations of both contractors and consultants providing the construction inspection/engineering services. Knowledge of day-to-day operations is construed to mean:

- Knowledge of current project status.
- Involvement in decisions relative to conditions which require change orders or supplemental agreements.
- Involvement in authorization of progress payments even though the consultant may furnish measurements or computation of quantities.
- Making periodic inspections, visits, or on-site reviews of the project; frequency dependent upon the magnitude and complexity of the project.
- The PM must verify that the consultant understands what records are required, how to record the data, and who can sign/verify each document. This is also true when a city or county does the project engineering.
- In regard to projects utilizing consultant inspection services, some misunderstandings have arisen when our acceptance date preceded a date when the county board "accepted" the project.
- Consultants utilized for engineering and inspection services must be given written notice regarding project completion dates. The consultant agreements usually specify the time allowed for the preparation and submittal of As-Built Plans and other final records, and the consultants need to be told when the clock has started. The consultant agreements state "The State will provide written notification of construction acceptance to the Consultant." At least one consultant has reported they do not receive the required notice.
- Feel free to be somewhat flexible in "starting the clock," but do put it in writing – and **send a copy of the letter to Project Development** so that he may begin his end-of-project paperwork, too. The consultant services

agreements and payments are audited by the Department, and it is important to have the notification documented.

102.11 PERSONNEL

102.12 EMPLOYEE POLICIES

Some of the [personnel references](#) that employees should read and follow include:

- Classified System Personnel Rules & Regulations
- Nebraska Association of Public Employees Labor Contract
- Safety Fact Sheets
- Nebraska Department of Transportation Operating Instructions

102.13 STAFF REQUIREMENTS

A definite need exists to develop and maintain procedures to properly manage engineering staff requirements necessary for highway construction projects. Proper planning and staffing procedures provide the means to estimate staffing needs based on anticipated workloads.

District Estimates

District Construction Engineers provide an estimate of staffing needs to the Deputy Director for each construction season. Each Project Manager analyzes their particular workload according to the production schedule, and District Construction Engineers collect and combine the data to determine minimum staffing for the upcoming construction season. These figures provide a guide for temporary employee hires (usually submitted in January or February each year).

Adjustments

As necessary throughout the year, the District Construction Engineers review their personnel requirements with the Deputy Director.

Field Personnel Duties & Staff Requirements

The District Engineer and District Construction Engineer are responsible for providing the Project Manager with a sufficient number of engineers and construction technicians to adequately and properly supervise and inspect the construction operations. The personnel furnished will have such education and experience, which, together with instruction, training, or direction by the Project Manager, will qualify them for the proper performance of the inspection or other duties assigned to them. It is the responsibility of the Project Manager to assign and utilize such personnel effectively and economically to obtain completed work of good quality and meeting the requirements of the plans and specifications.

102.14 SUBCONTRACTS

Subcontract Request And Approval

All subcontracts are subject to the requirements of *SSHC Subsection 108.01*, and FHWA 1273 (when included in the contract documents), and approval of contracting authority before they are recognized as valid. Subcontracts are required for independent trucking companies when hauling is covered by the provisions of Davis-Bacon wages (*Construction Manual 103.26*). Field forces shall not allow work to proceed without prior approval of the District Construction Engineer or District Engineer. Contractors are

expected to make their application for subcontractor approval sufficiently in advance to allow time for processing and approval. On rare occasions, this may not be possible. Under these circumstances Construction Division may provide verbal approval provided the contractor has submitted a written application for approval of the subcontract. If the contract has a DBE Goal, the DBE subcontractor may be uploaded into Site Manager by default. This does not mean they are automatically approved. You can check the 'Approval Date' in the Subcontract Record in Site Manager; if there is not an 'Approval Date' entered, then the subcontractor has not been approved yet. Contact the Construction Office for details.

1. Contractor's Requirements

The prime contractor must initiate a request to sublet items in the contract. This request must be electronically submitted to the Construction Division at NDOT.Subcontracts@nebraska.gov and shall include the following information:

- a. Subcontractor's name, mailing address, and telephone number.
- b. Prime contractor's identification number (used on employer's quarterly federal tax return, U.S. Treasury Department Form 941).
- c. A check off indicating whether or not the subcontractor is registered with the Division of Labor.
- d. Estimated starting and completion dates of the subcontractor's work.
- e. Items to be subcontracted with descriptions, quantities, unit prices, and amounts of non-specialty or specialty items. Unit prices shown must be the contract unit prices except when "labor only" or "place only" items are subcontracted. In such cases, indicate that the "item unit price" is approximate.

When a subcontracted item is used to satisfy a DBE goal, the amount paid to a DBE must be shown and verified with signatures of the prime contractor and the subcontractor. These signatures will document the agreement for payment between a prime contractor and their subcontractor and eliminate the need for a copy of a DBE subcontract/agreement. Note the additional guidelines on the administration of DBE subcontracts that follow.

- f. It has been common practice for subcontractors to include appropriate mobilization costs in their unit bid prices. Prime contractors may have encouraged this practice. However, adjustments in unit prices due to overruns or underruns will have to meet the test of "significant change".

To reduce the risk resulting from changes in quantities which are not subject to price renegotiation, appropriate use of the mobilization item for subcontractors is encouraged. On all subcontract requests, mobilization must be listed for the item even if the dollar amount listed/subcontracted is zero.

- g. The Subcontract Request and Approval letter shall include the following statement: ***"It is clearly understood by both the prime contractor and the subcontractor that all terms of the prime contract shall apply."*** When "Required Contract Provisions" (Form FHWA-1273) are part of the contract documents, the prime contractor is responsible to see that a copy of this form is physically attached to the subcontractor's copy of all

subcontracts. The prime contractor is responsible for fulfilling terms of the contract, including construction work completed by approved subcontractors, plus completing all required forms or reports. Refer to *SSHC Subsection 108.01* for requirements and limitations on contract subletting.

2. Project Manager Involvement

If a Subcontract Request is received by the Project Manager, it should be forwarded immediately to the Construction Division.

The Project Manager is responsible to make sure a subcontractor performs the kinds of work described in the approved subcontract.

Occasionally, contractors may have to rent additional equipment and hire extra employees to complete their work. However, when the entire crew and equipment of another contractor is used to complete the work, the prime contractor is violating the intent of *SSHC Subsection 108.01* and is considered brokering a project. If the District Engineer or the Project Manager observe work performed by anyone other than the approved subcontractors, the Construction Division should be notified. Assistance will be provided to investigate the circumstances.

At the preconstruction conference, it will be beneficial to discuss methods of keeping subcontractors informed of the work status. Although the prime contractor is responsible to make progress payments to a subcontractor, numerous incidents in the past have indicated a lack of timely progress payments from the prime contractor to the subcontractor. Subcontractors may review a copy of the "Contract Construction Progress Estimate" in the District office.

3. Field Approval of Subcontract Work

The District Engineers can approve a subcontract request for work up to a maximum amount of \$50,000 for each occasion.

There are some specific items that need to be kept in mind at all times when considering a request of the prime contractor to have certain work performed by subcontract. These are as follows:

- a. The contractor being considered to do the subcontract work must have been approved by the Department to perform as a subcontractor. A contractor is considered approved if he/she is prequalified to bid work; or is presently a prime contractor on a current project; or is an approved subcontractor on a current project; or has performed subcontract work in the past under the same company name. This information is available on the website at:
<http://dot.nebraska.gov/business-center/contractor/subcontracts/>.
- b. The subcontractor being considered must have current insurance. This information is available at:
https://ndorpubreports.nebraska.gov/ReportServer/Pages/ReportViewer.aspx?/AASHTOWare_Project/PreConstruction/Vendor_Insurance_Search&rv:DocMapMode=Displayed&rv:HeaderArea=BreadCrumbsOnly+.
- c. The aggregate total of all work to be subcontracted cannot exceed 70 percent of the contract amount, excluding specialty items identified in the contract.

If you are not able to determine the status of any of the above or have a question concerning the completion of the form, please contact the Construction Division at 402-479-4532 or NDOT.Subcontracts@nebraska.gov.

4. Exemptions from Subcontract Requirements

The following items of work may be exempted from the normal subcontracting requirements: (It should be noted, however, that these exemptions do not prohibit the contractor from executing a subcontract if he/she chooses to do so.)

Materials

- a. Small amounts of asphaltic concrete. When small amounts of material are needed to complete the work, such as for wedges at bridge ends, tying into existing surfaces, etc., the contractor will be permitted to obtain asphaltic material (and placement) from another contractor's portable (or commercial) plant without the need for a formal subcontract.
- b. Tack or prime oil. When small quantities or irregular areas are involved, the contractor may obtain this material from another contractor without the need for a subcontract. This exemption in no way relieves the contractor from furnishing material which meets the requirements of the specifications.

Equipment

- a. Concrete pumping
- b. Bump grinding. Equipment used for corrective grinding on asphaltic or Portland cement concrete pavement may be hired without the need for a subcontract. A subcontract is still required for any anticipated milling or grinding on a project.
- c. Fertilizer spreading

Services

- a. Plumbing. A subcontract will not be required for miscellaneous plumbing services (e.g., hook-ups, tap-ins.) or those situations where minor repairs or adjustments to existing plumbing are required as a result of other work included in the contract. A subcontract is still required for the installation of new water and sewer services shown in the plans.
- b. Sprinkler system work. A subcontract will not be required for those situations where minor repairs or adjustments to existing sprinkler systems are required. A subcontract is still required for the installation of new equipment.
- c. Engineering and Testing. Miscellaneous work performed by an independent engineering firm, such as for the relocation of section corners or conducting a mixer performance test, will not require the need for a subcontract. When contractor staking is included in a contract, a subcontract will be utilized when an engineering firm is employed to do the staking and surveying.

Other miscellaneous items of work may also be considered for exemption from the normal subcontracting requirements. Please contact the Construction Division if you have an item of work which you think may be eligible.

Regardless of whether or not work is exempted from the normal subcontracting procedures, contractors should be reminded that they are still responsible to see that all insurance and safety requirements are being met.

5. Subcontracting of Independent Truck Drivers

A contractor or subcontractor may wish to use another individual owner-operator or trucking company to supplement his or her hauling fleet. (The Department will not recognize multiple individuals claiming to be collectively identified as a single "owner operator.") This supplemental individual or company must either become a subcontractor (first tier or lower tier, as the case may be) or be otherwise documented by the utilizing contractor or subcontractor by entering into a lease agreement for the trucks and showing the driver (or drivers) from the supplemental company on the prime contractor's or subcontractor's payrolls in the manner described below. Payrolls will only be accepted from the prime contractor or approved subcontractors.

If the decision is made to subcontract the hauling, the prime contractor must first notify the NDOT Construction Office to request subcontract approval. As part of the subcontract approval process --- at any tier --- the proper certificates of insurance must be provided before approval will be granted. Additionally, on DBRA-covered projects, the prime contractor must submit payrolls for all subcontractors --- at any tier.

Owner/Operators of trucks hired by a contractor or subcontractor to supplement his or her hauling fleet are not subject to Davis Bacon. However, they must still be shown on a payroll prepared by the contractor or subcontractor for whom they are working with the notation "owner/operator." Any other employees of the "owner/operator" must appear on the certified payroll in complete detail and must be compensated according to the wage rates established for the project.

In the event a prime contractor or subcontractor elects to not subcontract the supplemental driver or drivers but instead chooses to "carry the workers/truckers on their payroll," the following requirements must be met:

- a. The prime contractor's or subcontractor's certified payroll must contain the names of all workers/truck drivers, and the payroll should identify their supervisors (including "owner-operators").
- b. Pay checks for the workers/truckers in question must be drawn against the prime contractor's or subcontractor's payroll or other account.
- c. Owner/Operators need only be identified as such on the payroll. Additional drivers, if any, from the "owner-operator's" company must appear on a payroll in complete detail and be compensated according to the wage rates established for the project.
- d. The prime contractor or subcontractor must enter into a lease agreement for the trucks driven by such drivers, and the lease agreement must show that the compensation for the leased equipment is on a time basis and not based on the amount of work accomplished. The lease agreements must be available for inspection by NDOT personnel.
- e. Any supplemental truckers employed under this arrangement must still carry the minimum automobile liability coverage specified in the contract.

Evidence of proper insurance must be presented for verification by NDOT personnel in the field.

Here are some example situations.

Scenario #1

ABC Construction utilizes John Smith and John Smith's truck to haul asphaltic concrete.

1. ABC can request John Smith Trucking as a subcontractor. Then, John Smith will have to furnish a certified payroll, and all it need show is John Smith's name ---- and identify him as an "owner-operator." ABC will compensate John Smith according to the subcontract agreement.

or

2. ABC can place John Smith on the ABC payroll, and he only needs to be identified as "owner-operator." Additionally, ABC must enter into a lease agreement with John Smith to lease his truck by the hour. ABC will compensate John Smith according to the lease agreement.

Scenario #2

John Smith owns John Smith Trucking and has two trucks. John drives one, and his son Dave drives the other. ABC Construction utilized John Smith Trucking to haul asphaltic concrete with both trucks.

1. ABC can request John Smith Trucking as a subcontractor. Then, John Smith Trucking will have to furnish a certified payroll, and all it need show for John Smith is his name - and identify him as an "owner-operator." The payroll from John Smith Trucking must also show Dave Smith as an employee of John Smith Trucking and be complete in every detail regarding Dave. Dave must be compensated according to the DBRA requirements and must be paid with a check drawn on John Smith Trucking. ABC will compensate John Smith Trucking according to the subcontract agreement.

or

2. ABC can place both John Smith and Dave Smith on the ABC payroll. John Smith can be shown as an "owner-operator," but Dave Smith must be shown on the ABC payroll in every detail. ABC must enter into a lease agreement for both of John Smith's trucks.

Dave Smith must be compensated according to DBRA requirements and must be paid with a check drawn on an ABC account. ABC will compensate John Smith according to the lease agreement for the trucks.

The work of producing and hauling materials by any party other than the contractor may, or may not, be considered as subcontracting, depending upon the classification and ownership of the materials or trucks used in hauling the materials. The work of hauling or producing materials under any of the conditions specified below shall not be considered as subcontracting.

- a. The production of materials from recognized commercial pits or plants.
- b. The hauling of materials from recognized commercial pits or plants in trucks owned or operated by the owner of the pit or plant.

- c. Any hauling of materials by a recognized commercial hauling company.
- d. Any bona fide lease agreement between the contractor and the truck owner. This is applicable only if the truck driver is on the contractor's payroll.

A recognized commercial pit or plant shall be considered to include any pit or plant which was producing or processing materials for sale prior to the date of the award of the contract.

The term "recognized commercial hauling company" shall include any common or contract carrier who has obtained an "RC" permit to operate as such.

To determine if a company, such as a barricade or signing service company, is doing work requiring subcontracting approval, the following guidelines will be used.

If the company only provides and delivers the materials to the project site, he/she is considered to be a material supplier and a subcontracting approval is therefore not required. If, however, in addition to the above, the company also performs any work of installation, maintenance, or removal and salvaging (such as of signs, posts, fasteners, etc.,) on the project site, subcontracting approval is required.

If a prime contractor elects not to subcontract but to "carry the workers on the payroll", the question may arise that an unauthorized subcontract may actually exist. The Project manager should then perform the following checks:

- a. Check the prime contractor's payrolls to determine if the workers in question and their supervisor(s) are included on their payroll, except for those persons working for and listed on an authorized subcontractor's payroll.
- b. Request a copy of the lease agreement on equipment to ascertain that compensation is on a time period basis rather than the amount of work accomplished.
- c. Check material supplier invoices or billings to ensure that the prime contractor is or will make payment for the materials used in the work in question.

If the above conditions are satisfied, it can be assumed that an authorized subcontract exists. However, if any or all of the above conditions are not satisfied, the matter should be immediately brought to the attention of the District Construction Engineer for further handling, and the prime contractor should be immediately notified of the unsatisfied condition or conditions.

The conditions referenced above can only be met concurrently or after work on the project has started. A condition may arise where work has been performed prior to approval of a subcontract, thereby making such work ineligible for payment. It is, therefore, vital that in addition to a discussion of subcontracting requirements at the preconstruction conference, the contractor be informed that the above mentioned checks will be made in the event that he/she elects to place the workers on the payroll rather than subcontract.

102.15 DETOUR REPORT

During the construction season, detour and shoofly maps are prepared every month to show roads closed for construction or under construction but open to traffic with restrictions. You should forward information for these maps to the Communications and Public Policy Division via email by the 20th of each month.

The District Engineer or their representative is responsible for identifying when project work will begin and end, restrictions in vertical and horizontal clearance through the work zone, and other information identified on the Detour Report. *It is extremely important that the information provided be current and accurately represent all traffic restrictions and detours in effect.* This information should be reported as soon as the construction schedule is known so the information is available for Motor Carriers when applying for truck permits.

102.16 CONTROL NUMBERS AND CONTRACT NUMBERS

With the exception of letters for the Governor's signature, correspondence, including electronic correspondence, relating to a specific highway project will include the project number, location, and control number.

102.17 PROJECT DOCUMENTS DISPOSITION

Contract Compliance Review

Documents pertaining to EEO shall be retained in OnBase for a minimum of three years.

Contract Payrolls

Salaries and wages paid to individual employees of contracting firm that receives low bid awards. District Construction Office stores in OnBase for a minimum of three years.

Contract Records

Including the following: prequalifying prospective bidders, qualifying low bidders, advertising of bids, engineer's estimates, awards of contract and concurrences, agreement estimates, anti-collusion, certifications for force account construction, award and execution correspondence, letting information (such as plan orders, etc.), and any similar records considered necessary to document the contract. Store for 25 years in OnBase.

103.00 PRECONSTRUCTION

103.00 PRECONSTRUCTION

103.01 PRECONSTRUCTION CONFERENCE

As soon as practical after a contract is awarded, the Project Manager will arrange a preconstruction conference with the contractor. The number of people attending this meeting will depend upon the complexity of the job. Usually it includes:

- Project Manager and assistants in charge of the project
- Environmental Project Manager
- District Engineer
- District Construction Engineer/Assistant DCE
- Design Engineer

- Prime contractor
- Subcontractors (have prime invite them)
- Utility and railroad companies
- Local government (city and county) when associated with project

The following agencies may, on certain projects, be invited:

- Federal Highway Administration division office
- Law enforcement - highway patrol, sheriff, or city police
- Construction Office
- Highway Civil Rights office

The conference is usually conducted by the Project Manager. During introductions by the Project Manager, a form for names, addresses, and phone numbers of those present should be circulated. Minutes of the meeting should also be kept by the Project Manager and copies sent to all interested parties.

The purpose of the conference is to discuss:

- Safety of employees and the public (*SSHC Subsection 107.07*).
- The project plans and specifications.
- Unusual conditions and constructability.
- Utility requirements (*SSHC Subsection 105.06*).
- Erosion Control Plans.
- Contractor's plan and schedule of operation (*SSHC Subsection 108.07*).
- Type and adequacy of equipment.
- No materials are to be incorporated in the project until approved by the PM. All electrical materials must be approved by the Construction Division before any electrical work begins.
- Material Suppliers.
- Sources of labor and labor requirements.
- Maintenance of traffic and business access.
- Other pertinent items that will result in a better job understanding.
- Partnering opportunities.

103.02 ADMINISTRATION DETAILS

Before discussing any project details, Subsections 103.00 to 103.61 of the *Construction Manual* may be distributed to the contractor and subcontractors at the Project Manager's option.

Administrative issues to be discussed at the preconstruction conference include:

1. Change Orders

Before commencing any work not covered by the contract, the contractor and the Project Manager must agree on the price or prices to be paid for the work (or the method used to determine them). Extra work performed before this agreement is reached cannot be considered for payment. The basis of payment for the cost of extra work follows four general categories:

- Contract unit prices
- Agreed unit prices
- Agreed total prices
- Force account

On force account work, the contractor is required to prepare payrolls and invoices, for labor, equipment and material furnished, using a "Force Account Agreement" (NDOT Form 058). This form shall be signed by the inspector and contractor's representative at the end of each day's work. Both the contractor and inspector will retain a copy.

2. Contract Documents

Contractors must see that copies of plans, specifications, and special provisions are available at all times to their representatives on the project. Plan revisions will be mailed to the contractor as soon as they are issued. Contractors will be responsible for keeping their field representatives informed and supplied with such revisions. If contractors feel such revisions require extra work, they should immediately advise the Project Manager.

3. Wage Rates (Federal Aid Projects)

All wages paid must conform to wage and hour provisions prescribed in the contract.

Crafts must be listed exactly as shown in the wage decision. Crafts not listed but needed shall be requested by the contractor through the Project Manager. Required payrolls must be submitted weekly and within seven days after the last day covered by the payroll.

It is suggested that the prime contractor collect, sign, and submit all payrolls of approved subcontractors, as a group, to the Project Manager.

The Project Manager may withhold progress estimates if payrolls are more than two weeks behind schedule.

4. Postings

The contractor shall be responsible for erecting and maintaining required postings as outlined in *Construction Manual* Subsections 103.21 to 103.24.

5. Stockpiled Material

If contractors want payment for stockpiled material, they should provide receipted bills showing the actual cost of the material stockpiled. For payment of stockpiled material, refer to *Construction Manual* 105.06.

6. All plants shall be labeled.

The information on each plant's label shall described the plant's:

- a. Botanical genus.
- b. Species.
- c. Common name.
- d. Size or age.

Legible labels shall be attached by the nursery grower to individual plants, boxes, bundles, bales, or other containers to insure that all species and varieties are identified.

7. Subcontracting

- a. On all projects, prime contractors must submit their subcontract requests to the Construction Division in writing.
- b. The prime contractor is responsible for EEO and minimum wage compliance by all subcontractors.
- c. All subcontractors must be approved by the Construction Division prior to the subcontractor starting work.
- d. In the event a prime contractor elects not to subcontract and instead "carry the people on the payroll", the District Engineer or their authorized representative may perform the following checks:
 - (i) Request to see on a random basis and before distributing the payroll checks of the people in question.
 - (ii) Request a copy of the lease agreement on equipment to verify that compensation is on a time period basis rather than the amount of work accomplished.
 - (iii) Check material supplier invoices or billings to insure that the prime contractor is or will make payment for the materials used in the work in question.
 - (iv) Check the prime contractor's payrolls to determine if the people in question and their supervisor(s) are included on the payrolls.

8. Project Supervision

The prime contractor shall submit in writing, to the Project Manager in charge, the name of an authorized representative on the project. Representative will be empowered to coordinate with all operations of subcontractors and negotiate with the Project Manager any questions concerning extra work, including extra work performed by a subcontractor. If the prime contractor wishes, this representative may be a subcontractor's employee that is present when work on the project is being performed.

9. Weekly Report of Working Days

When working time is being charged, the Project Manager will prepare and furnish the contractor the "Weekly Progress/Working Day Report" showing working days charged that week. Objections to days charged must be made in writing by the contractor within fourteen calendar days after the report was made available. Objections based on delays due to unavailability of materials should be

accompanied by copies of orders placed, acceptance of orders, and promised dates of delivery. All other objections must be accompanied with documentation of the reason for objection. The Project Manager will respond to the objection, indicating acceptance of the claim or reasons for rejection.

10. Right of Way

All parties are reminded that highway right-of-way abuts private property. Any infringement or trespassing upon such private property could cause damage that would become a liability to the person or organization involved. Maintaining good relations with the public (especially private property owners) is very important.

11. Safety

Contractor must comply with provisions of the Federal and State Occupational Safety and Health Acts.

12. Nebraska One Call Notification System shall be explained by the Project Manager. The Diggers Hotline of Nebraska phone number is 1-800-331-5666 – the website is <https://www.ne1call.com/>.

13. Contractor has 48 hours to file notice with county sheriff when burial sites are discovered.

14. Water Pollution & Wetlands

The contractor's schedule and methods for control of water pollution and protection of wetlands should be reviewed. For more information, refer to Construction Manual Division 1100.

All disposal sites require NDOT approval.

15. EEO Requirements (Federal Aid Projects)

a. FHWA form PR-1391, required annual manpower reporting. (Distribute sample form)

(i) The Contractor (prime and subs) shall send completed copies to highway Civil Rights Office.

(ii) Submit by 15th of August.

(iii) The reporting period is for the last full week in July.

(iv) EEO Self-analysis form.

(v) Required of all primes and also any subcontractor with a federal-aid contract of \$10,000 or more.

(vi) OJT Monthly reporting.

b. All subcontract and purchase agreements must include E.E.O. provisions.

A. All sections of Form PR-1273 must be attached to these agreements.

c. Not allowed to maintain segregated facilities of any kind.

d. Must pay comparable wages.

e. Contractor must adopt an EEO policy statement.

(i) Post it on job site and in home office.

- (ii) Send it to outside referral sources.
- f. Designate an E.E.O. Officer.
 - (i) Should be in writing and signed by policy officer of the company.
 - (ii) Send the notice of designation to NDOT Highway Civil Rights Office.
 - (iii) Post this designation where employees can see it.
 - (iv) E.E.O. Officer must be someone with authority to carry out the requirements of the EEO Program.
- g. Conduct E.E.O. meetings with supervisory personnel before the job starts.
 - (i) Review all the requirements of the contract.
 - (ii) Meetings must be held at least every six months.
 - (iii) Document and keep records of these meetings. (Can be formal minutes or diary notes).
- h. Disseminate E.E.O. policy to employees.
 - (i) If done by meetings, document and record. (Diary Notes acceptable)
 - (ii) May be done by pamphlets or other handouts.

There is no set way of doing this. The contractor may use whatever system works best for the company. However, the company must be able to document that employees are told about E.E.O.
- i. Put up E.E.O. posters.
 - (i) Two required - Federal and State.
 - (ii) Must be at job site and home office.
- j. When advertising for jobs, he/she must include the notation "An Equal Opportunity Employer". Should keep copies of ads.
 - (i) When advertising, place ads in local commuting area of job site.
 - (ii) Use newspapers and other media likely to yield minority and female applicants.
- k. When hiring, the contractor should show some active recruitment in local commuting area of job site.
 - (i) Make personal recruitment visits to organizations, agencies, etc. in the commuting area of the job site.
 - (ii) Write letters of recruitment to organizations and agencies in the local commuting area.
 - (iii) Keep records of all recruitment activity (diary notes are acceptable for personal visits).
- l. Must show that some attempt is made to analyze the labor market where the job is located.

- (i) Determine number of minorities and women in the commuting area of job site.
 - (ii) Analyze staffing pattern of crew at job site.
 - (iii) Set up some type of goal or objective for utilizing minorities and women on that particular job. If minorities and women will not be utilized, be prepared to explain why. Keep records of this analysis activity.
- m. Will need to show that personnel actions are reviewed by top management for discriminatory effects.
- (i) If a minority or women is discharged at the job site, make sure that the home office knows about it and that the company E.E.O. Officer gives the facts surrounding that discharge.
 - (ii) If a minority or women is transferred or promoted, the E.E.O. Officer should know about it.
- We are not advocating that contractors establish a highly formal procedure for this, because in some cases, it would not be practical or feasible. However, it is the contractor's responsibility to show that this is being done regardless of the method used.
- n. Must show some type of training activity. Must advise employees about training opportunities available and encourage minorities and females to participate.
- (i) Document progress of trainees.
When training is given on an informal basis, the contractor will need to show that it is given. Records of case histories should be kept, subject to being verified by interviewing the trainee involved. Keep records of all training activity.
- o. Keep records of the following:
- (i) Number of minority and women applicants referred and where they come from.
 - (ii) Number of minorities and women hired - if not hired, reasons why.
 - (iii) Number of minorities and women transferred, terminated, promoted, etc.
- p. Identify minority and women employee files after hire.

Note: Each Federal-Aid project will stand by itself when being evaluated for affirmative action. In other words, affirmative action on one project will not satisfy the requirement of affirmative action on another project. The contractor should satisfy himself/herself that the foregoing actions are taken and that records are kept for each and every project under their control.

103.03 PROJECT DETAILS

1. On many projects it may be necessary for the Project Manager to prepare and present an enlarged plan or map for showing:
 - Location.
 - Terminal points.
 - Type of construction involved.
 - Special areas of concern, including installation of public utilities to be fenced or marked if hazardous or sensitive.
 - Restrictions due to lack of right-of-way or defined by right-of-way agreements.
 - Detours and staging of construction for traffic.
2. Contractor must present their detailed construction schedule, or else postpone preconstruction conference. Schedule shall include a clearly identifiable critical path.
 - a. Starting Date _____ Completion Date _____
Any date before Notice to Proceed must be approved in writing by the Construction Division.
 - b. Staging Schedule or Sequence of Operation.
 - c. Items to be sublet and names of subcontractors.
3. Sampling and material testing requirements shall be discussed.
4. Contractor Insurance requirements shall be verified.
5. Railroad Protective Insurance.

The contractor must have appropriate insurance in force when working on the railroad right of way.

Upon receipt of the Railroad Protective and General Liability certificates of insurance in the Construction Division, the policy effective dates will be entered in SiteManager. However, the Project Manager must, in the Key Dates area of SiteManager, record the date that construction in the railroad right-of-way started and ended. **Check to make sure that Railroad Protective coverage is in force.** Do not allow the contractor on the railroad right-of-way if you do not see it in SiteManager. Call the Construction Division at (402-479-4532) so they can verify that all railroad insurance is on file.

6. Utilities and Law Enforcement Attendance

At major project preconstruction meetings, attendance of utilities, law enforcement, and fire and rescue personnel is highly beneficial to all concerned. The Project Manager should expend extra effort to assure attendance or open communication with utilities and appropriate law enforcement agencies.

Relocation of utilities is of extreme interest to all concerned in the progress of the project. For safe control of traffic, the ability to discuss traffic control with both contractors and law enforcement could be highly beneficial. The State Patrol, local sheriff, or police should be invited to attend preconstruction meetings when

appropriate. The State Patrol can be contacted through the State Patrol District Office charged with responsibility for the area of the project being discussed.

It is beneficial to discuss utilities relocation, project staging, or traffic control early in the meeting before more detailed and time consuming construction matters are approached. You may excuse utility companies early.

7. Plan and specification omissions must be discussed.
8. Traffic Control (PM shall present the NDOT Traffic Control Plan.)

In addition, the following must be verified:

- a. Brand and model of barricade light proposed to be used are on the Approved Products List.
- b. Maintaining spare parts on project.
- c. Checking barricades and signs at frequent intervals daily.
- d. Phone number of person to call at night if barricades, or signs or devices are down or not working.

Name and Number _____ - _____

Name and Number _____ - _____

- e. Notify Project Manager before picking up signs and also at first notice of damaged or stolen signs.
9. Prompt Submittal of Certificates of Compliance, Certified Analysis etc. to insure payments.
 10. Location of Field Laboratory and Field Offices.
 11. Subcontractors must be approved before they can begin working on project. We need to be notified when they are going to be working on project.
 12. Contractor's Borrow Pits – Approval.
 13. Payrolls – Prime Contractor needs to check subcontractors.
 14. Welding on girders not allowed without written permission.
 15. Labor, Payrolls, Wage Rates, Training & E.E.O.
E.E.O. Officer _____
Safety Officer _____
 16. Extra Work Orders

Before commencing any work not covered by the contract, the contractor and the engineer must agree on the price or prices to be paid for the work. Extra work performed before this agreement cannot be considered for payment.

103.04 ADDITIONAL TOPICS FOR DISCUSSION

- Anticipated work starting dates.
- Clean up of cast-in-place concrete structures.
- Staging schedule.
- Falsework plans and falsework removal.

- Presentations by various utility representatives.
- Please remind contractors at the preconstruction conference that they or their suppliers are required to furnish 2 (two) 2.0 m (6 foot) sample lengths of reinforcing bars whenever such samples are called for in the *Standard Specifications* or *Materials Sampling Guide*.
- Signing, barricades, pavement marking, warning lights, and other temporary traffic control devices according to:
 - ◆ Department responsibilities (*SSHC Sections 422 and 423; Subsections 104.05, 105.01, 107.07, and 107.14*).
 - ◆ Contractor responsibilities (*SSHC Sections 422 and 423; Subsection 104.05, 105.05, 107.07, and 107.14*).
 - ◆ Contractor's work plan (*SSHC Subsection 108.07*).
- Project Lighting (if applicable).
- Remind contractor when ordering piling, he/she must tell manufacturer to stamp the heat number on the piling. (*SSHC Subsection 703.02*)
- Presentation by county or city representatives.
- Names and chain of command for state or county forces assigned to project.
- Authority and duties of inspector. (*SSHC Subsection 105.05*)
- Assignment of contractor's personnel for:
 - ◆ Person responsible to maintain traffic control devices (24 hour call number). (*SSHC Subsection 422.01*).
 - ◆ Person authorized to make decisions and sign extra work orders, etc.
 - ◆ Project safety officer.
 - ◆ EEO officer.
 - ◆ Project supervisor (*SSHC Subsection 105.05*).
 - ◆ Disadvantaged business enterprise liaison officers.
- Discussion of items to be sublet, names of subcontractors, and commercially useful function of DBE subcontractors, suppliers, and manufacturers should be discussed.
- Construction staking requirements.
 - ◆ The contractor must avoid destroying stakes
 - ◆ The contractor must advise Department 48 hours in advance of requirement.
- Equipment to be used - contractor should identify equipment with greater than legal axle loads that is to be moved across bridges or pavements that will remain in place. Equipment with greater than legal axle loads (*SSHC Subsection 105.11*) must be either loaded on an appropriate trailer or specifically exempted. Requests for exemptions will be analyzed

on a case-by-case basis by the Construction, Bridge, and Maintenance Divisions.

- Special notes on plans or proposals and special or unusual provisions that apply.

Safety precautions and compliance with:

- ◆ Posting of OSHA Form 200.
- ◆ Public Convenience and Safety (*SSHC Subsection 107.07*).
- Contract quantity settlement.
- Frequency of estimate vouchers (normally once or twice each month).
- Covers on trucks hauling on highways when necessary.
- Specified working period.
- Contractor's submittal of work plans for:
 - ◆ Control of water pollution and erosion (*SSHC Sections 201, 204, and Division 800*).
 - ◆ Control of fugitive dust.
 - ◆ Compliance with storm water discharge requirements (*Construction Manual 1100.30*).
- Equal Employment Opportunity responsibilities for statement of compliance and required postings (*Construction Manual 102.23*).
- Statements by Federal Highway Administration and visiting Commission personnel.
- Pre-concreting conferences.
- Value engineering incentive proposals submitted by the contractor (*SSHC Subsection 104.03* and *Construction Manual 103.09*).
- Partnering Opportunities (*SSHC Section 113*)
 - ◆ Workshops/Training
 - ◆ Dispute resolution procedures
 - ◆ Meeting schedule/location

103.10 ONE CALL NOTIFICATION

It is the law; anyone who digs a hole, pushes a pipe through the ground, or even moves a stockpile of gravel must contact Diggers Hotline first. The Diggers Hotline phone number is 1-800-331-5666.

Fiber Optic Cable Buried on Railroad Right-of-Way

Railroad Points of Contact for Location of Fiber Optic Cable

Burlington Northern Santa Fe Railway	800-533-2891
Nebraska Central Railroad Company.....	800-336-9193
Nebkota Railway	308-282-1550
Nebraska Northeastern Railway Company	402-748-3535
Nebraska Kansas Colorado Railnet	817-571-2356
Union Pacific Railroad	800-336-9193

Most railroad lines have fiber optic cables buried in the right-of-way.

The Union Pacific Railroad has an "800" number available 24 hours a day to determine if fiber optic cable is buried on their right-of-way.

The number is 1-800-336-9193. Anyone calling the "800" number will need to give the railroad milepost number to the operator.

When we have a construction project that may involve railroad right-of-way, a railroad special provision will be added to the bid proposal. The contractor will be required to call the appropriate "800" number before working on railroad right-of-way. The railroad milepost number will be included in the special provision.

Project Managers should confirm that the contractor knows how to get clearances.

103.11 UTILITIES AND RAILROAD REHABILITATION

1. General - Work by utility companies and railroads in making necessary rehabilitation of their facilities for our project construction will often require certain advance preparations by the Project Manager and cooperation with the firm during the progress of their work. In many cases it will be necessary that our right-of-way be defined by setting of stakes prior to beginning rehabilitation work. Grade stakes may be required at railroad crossings or in connection with pipe line or pole line work on the project. The firm involved will generally be responsible for furnishing their own stakes needed for the actual rehabilitation but will need basic information from which to work. Cooperation with these firms will assist in getting their facilities out of the way of our construction.
2. Preventing Damage to Utility Properties - The Project Manager should document that proper precautions are taken to protect and prevent damage to the property of railroads, underground or overhead utilities, and pipelines in connection with highway construction work.

No excavation will be permitted in the area of underground utility facilities until all such facilities have been located and identified to the satisfaction of all parties. The excavation must be accomplished with extreme care in order to avoid any possibility of damage to the utility facility.

3. Beginning Rehabilitation - The utility firm will generally begin work shortly after they have been notified to proceed. The Project Manager should provide them with information regarding the contractor's schedule as soon as possible, if the facilities will be a material delay to progress of the construction. This will allow the firm to schedule rehabilitation work in an order of priority over other rehabilitation.

The Utilities Section of the Project Development Division tells the utility companies to advise the Project Manager by letter when they begin work, their

tentative progress schedule, the name and address of their person in charge of the work. The Utilities Section of the Project Development Division also tells the utility company to furnish the Project Manager (and copy to utilities officer) with the completion date of the revision work. These letters are to be confirmed with appropriate field book entries.

4. Inspecting Rehabilitation Work - Whenever an agreement provides that certain items of work are to be performed by a municipality, railroad, or utility, contact with the work should be maintained. If the work is to be done at state expense, the Project Manager shall keep a record of the work in sufficient detail to enable him/her to determine that the charges are justified and in accordance with the agreement. However, on most work of this nature, it would be difficult to keep a detailed record of each and every item without involving considerable expense. The Project Manager should consult with a representative of the organization involved and arrange to obtain information as the work progresses on the labor, equipment, and material used in the work and the material salvaged for future use.

In some cases, such as the placing of pipeline crossings, ditching and backfilling in the roadway area may require inspection to insure that compaction of the backfill is properly performed.

The Utilities Engineer no longer requires that you keep and submit a separate field notebook for all utility agreements. He/she does, however, ask that you notify him/her of the completion date for all utility work on your projects.

Your inspection and documentation of utility rehabilitation work should be limited to the amount necessary to complete the information required when using the UTILDONE program.

103.12 HAUL ROADS (SSHC Section 107)

Prior to beginning any work, the contractor is required to meet with all involved local governmental entities and advise them of any intentions to use their local roads. The contractor shall be responsible for resolving claims concerning damage to local roads caused by their operation.

The contractor shall protect and indemnify the State and its representatives against any claims or liabilities arising from damage to local roads caused by the contractor's operation.

103.20 CONTRACT ADMINISTRATION (SEPARATE HANDOUT FOR ALL CONTRACTORS)

This section provides instructions and guidance to contractors and Project Managers for administration of construction contracts. Instructions include information on required reports or forms, equal employment opportunity, wage reports, training program, minority recruitment, and subcontracting.

103.21 NEBRASKA & FHWA FORMS & REPORTS - PREPARED BY CONTRACTOR

Form No.	Title	Reference Section	Office Where Forms are Available
NDOT298	Training Special Provision Monthly On-Job-Training Report	102.24	Highway Civil Rights
NDOT website	EEO Contractor's Self-analysis	102.23	
FHWA PR-1391	Annual EEO Report	102.23	Highway Civil Rights
FHWA-47	Statement of Material & Labor	102.25	Construction
WH 348	Statement of Compliance	102.25	District Const. Office
Standard Form 1444	Request for Authorization, Additional Classification and Rate	102.26	Construction

Postings

At the preconstruction conference, the Project Manager will supply copies of the posters listed below:

1. Federal-Aid Contracts

- [Equal Opportunity is the Law – \(federal poster\)](#)
- [State of Nebraska Equal Opportunity Commission – \(state poster\)](#)
- [WH-1420 Family Medical Leave Act \(US Dept. of Labor, Wage/Hour Division\)](#)
- [WH-1462 Employee Polygraph Protection Act \(US Dept. of Labor, Wage/Hour Division\)](#)
- [FHWA-1022 False Statement Notice \(Federal Highway Admin.\) *](#)
- [WH 1321 Wage Rate Information \(US Dept. of Labor, Wage/Hour Division \(2009\) *](#)
- [Whistleblowers Rights \(US Dept. of Transportation\) **](#)

2. State Funded Contracts

- [NEDOL-Employee Rights, Nebraska Minimum Wage \(Nebraska Dept. of Labor\)](#)
- [WH-1420 Family Medical Leave Act \(US Dept. of Labor, Wage/Hour Division\)](#)
- [WH-1462 Employee Polygraph Protection Act \(US Dept. of Labor, Wage/Hour Division\)](#)
- [Equal Opportunity is the Law – \(federal poster\)](#)
- [OSHA 3165](#)

Additional copies, if needed, can be obtained from the Project Manager or the Construction Division. In addition to postings noted above, a copy of the Policy Statement shall be posted.

All required site postings shall be in a location that is easily accessible to all employees. They may be fastened to a bulletin board, tool shed, or job office trailer and protected from weather by glass or clear plastic. Postings that become soiled, faded, or otherwise illegible should be replaced. More than one posting may be necessary if there are multiple locations where workers report for work. Such cases typically occur on complex or long projects involving several different crews or subcontractors.

103.22 OCCUPATIONAL SAFETY AND HEALTH

Occupational Safety and Health Act (OSHA) regulations (federal and state) apply to all construction projects. (Federal OSHA regulations are codified in *29 CFR, Sections 1910 and 1926.*) Contractors are responsible for compliance with OSHA regulations and shall maintain a safe work site. Therefore, contractors and their employees must be familiar with the health and safety requirements of the act.

- As an employer, contractors are required to keep employee occupational injury and illness records at the location where their employees usually report for work. The "Log and Summary of Occupational Injuries and Illnesses" (OSHA Form 200) must be completed within six days following a recordable occupational illness or injury. A copy of the completed form must be maintained at the work site. In addition, OSHA Form 200 is to be completed at the end of each calendar year and posted at job sites before February 1. Detailed instructions are printed on the back of each form.
- A poster entitled "Safety and Health Protection on the Job" must be displayed in a prominent place at all times.

Contractors can obtain OSHA forms and posters from:

Regional Director-OSHA Federal Office Building Lincoln	or	Administrative Safety & Labor Standards Division Department of Labor Lincoln
--	----	---

103.23 EQUAL EMPLOYMENT OPPORTUNITY (EEO) (SSHC Subsection 102.09)

1. Contractor's Responsibility

Contractors and their staff who are authorized to hire, supervise, promote, and discharge employees or recommend such action must understand the requirements of applicable EEO specifications including "Required Contract Provision", Form FHWA 1273, and Executive Order 11246 in the Special Provisions.

Policy Statement and Compliance Letter

All contractors must formally adopt an Equal Employment Opportunity Policy Statement which:

- Prohibits discrimination of any kind or for any reason.
- Encourages employment of minorities and women.

2. Project Manager Involvement

Responsibility for complying with EEO requirements is solely the contractor's. However, the Project Manager has oversight involvement to ensure that contractors comply with these requirements and that proper forms or letters have been received. When a contractor is not in compliance with EEO requirements, the Project Manager shall advise the contractor, in writing, and make a diary entry, that continued negligence in EEO requirements will result in the withholding of progress payments. The Project Manager will also inform the Contract Compliance Officer of the contractor's noncompliance. The Contract Compliance Officer will investigate all reports of noncompliance and make a recommendation as to what the contractor must do to be in compliance. If the

contractor still fails to take corrective action relative to EEO noncompliance, the Project Manager may, with concurrence from the Construction Engineer (Lincoln), suspend work. All suspensions shall be documented in writing and sent to the contractor.

a. Contracts and Subcontracts Over \$10,000

(i) Site Inspections

As soon as a major part of contract work is underway, an EEO project site inspection must be completed by the EEO Office relative to work in progress. A representative of each affected company shall be present and accompany the inspector during an EEO inspection.

(ii) Training Program

Contractor training special provisions requires the contractor to have a formal employee training program. During an EEO inspection, the training program should also be checked.

(iii) Required Posting

During the inspection, all required postings should be checked. Project Managers shall check to see that correct names and addresses appear in the boxes on posters entitled "Wage Rate Information Federal-Aid Highway Project" (FHWA-1495) and "Notice" (FHWA-1022).

(iv) Reports

- "Federal-Aid Highway Construction Contractors Annual EEO Report"

All prime contractors and any lower-tier subcontractors with a federal-aid highway construction contract of \$10,000 or more must annually complete a FHWA PR-1391 "Federal-Aid Highway Construction Contractors Annual EEO Report" form for each separate federal-aid contract for which the firm performed work during the last full week of July of the current year. Completed forms are to be submitted to the NDOT Highway Civil Rights Office no later than August 15.

Prime contractors are NOT responsible for submitting contractor reports; however, they are responsible for ensuring all subcontractors are aware of the EEO Contract Special Provisions.

A blank copy of the Form FHWA PR-1391 can be obtained from the Civil Rights page of the Business Center section of the NDOT website. Copies may also be requested from:

Highway Civil Rights Office
Nebraska Department of Transportation
1500 Hwy. 2
P.O. Box 94759
Lincoln, Nebraska 68509-4759

Phone: (402) 479-4531
Fax: (402) 479-3728
Email: Troy.Larsen@nebraska.gov

Instructions for completing the form are provided by the Highway Civil Rights Office on a yearly basis. Contractors are cautioned to be sure they have the CURRENT instructions. If there is any question about revision dates, contact the Highway Civil Rights Office.

- b. Construction Contracts and Subcontracts \$10,000 and Less
An EEO project site inspection is not necessary for these construction contracts.
- c. Maintenance Contracts
On maintenance contracts, an EEO project site inspection is not necessary regardless of contracted amount.
- d. Complaints of EEO Violations
The Project Manager will report all complaints of EEO violations to the Construction Division's EEO section for investigation.

103.24 TRAINING & TRAINEE PROGRAMS

Contractor's Responsibility

1. Training Program

All prime contractors and subcontractors (with contracts over \$10,000) must develop, or have, an approved training program in accordance with the *Specifications*. The Highway Civil Rights Office approves these programs and can be contacted [(402) 479-4514] for answers to questions or assistance in developing an approved program.

Shortly after a contract is awarded, the Contracts Office will verify that the successful bidder has an approved training program on file. If not, the contractor will be advised that a formal training program must be approved by the Contracts Office within 30 days. Failure to submit a training program will be considered noncompliance with the *Specifications*. A contractor who does not comply may be refused bidding proposals for future lettings until requirements for a training program are met. (Typically, contractors adopt and use the Associated General Contractors' (AGC) training program. It is acceptable in Nebraska.)

An acceptable training program shall include information covering:

- Method of trainee recruitment.
- Crafts to be trained and upgraded.

- Number of expected trainees per year and what part of total will be female, minority, and disadvantaged.
- Training procedures, including approximate training time.
- Commitment for keeping up-to-date records to summarize total time each trainee is trained in each classification.
- Proposed use of trainee upon successful completion of training program and commitment to issue a certificate or statement of successful completion of training.
- Number of total work force (Nebraska operation).

2. Trainee Program

Contractors responsible for fulfillment of reimbursable training hours on federal-aid projects must obtain written approval from the Highway Civil Rights Office for each trainee prior to the trainee's enrollment in the program.

- a. Contractors shall submit their written requests for trainee approval to the Construction Division, attention EEO Section, with a copy to the Project Manager. Requests must include job classification, number of hours to be fulfilled, trainee name, race, sex, address, phone number, and social security number.
- b. If additional trainees or replacements for terminated trainees are needed, crafts and classifications must be approved by the Project Manager with a follow-up letter to the EEO Section. Hiring of non-minority trainees to replace semi-skilled or skilled workers may not be used to establish eligibility for federal reimbursement since the trainee program is designated for members of female, minority, or disadvantaged groups.

Note: Changes to the number or class of trainees initially requested must be submitted and pre-approved by the Construction Division.

c. Trainee Reimbursement

In order to qualify for trainee reimbursement:

- Trainees must be registered in the appropriate program.
- Wage determination decisions of the Davis-Bacon Act are used as the basic rate on any project involving federal aid.
- Minimum starting wage will be 60 percent of the rate established for a craft or classification for the first half of a training period. This percentage will change to 75 percent for the third quarter, and 90 percent for the last quarter. Certified payrolls shall specifically identify each individual in trainee status, their base rate, and applicable reduction percentage.
- After a trainee has completed their training program, the trainee's base wage rate shall be increased to Davis-Bacon's wage determination for that job classification.

3. Trainee Recruitment

The contractor's trainee program outline must include method of recruitment.

Occasionally, it may be impossible to recruit members of minority groups due to minority unavailability at the project location. When this occurs, contractors must have documented their efforts in attempting to recruit minorities. The Project Manager and the Construction Division EEO Section should be informed of recruitment problems. Recruitment which results in an inadequate number of minority trainees does not eliminate a contractor's responsibility to fulfill the requirements of the "Trainee Reimbursement bid item.

If minority recruitment results in less than the required number of qualified individuals, the contractor shall then recruit non-minorities or use some of their own employees for the training program. Any non-minority substitution requires preapproval of the Project Manager and the Construction Division (EEO Section).

4. Reports

- "Reimbursable Trainee Training Record"

Each month the contractor must submit a NDOT Form 298 "Special Training Provision Monthly On-Job-Training Report."

- If no trainees are employed during the early phase of work, the contractor shall so advise the Project Manager and the Construction Division (EEO Section).

Project Manager's Involvement

1. Training Program

Project Managers shall have a copy of the approved training program. Copies may be obtained from the contractor or the Construction Division (EEO Section). Since training programs have been standardized by AGC, any preapproved program can be used as a model for evaluating a particular contractor's program during inspection.

For convenience, training program inspections will be made concurrently with EEO inspections. An inspection will include interviews with individuals enrolled in the training program. Also, the contractor's training program will be spot-checked. A copy of the contractor's program shall be available for review.

The Construction Division shall be notified if:

- A contractor does not have a training program.
- The contractor's program is deemed inadequate.
- Other training deficiencies are noted during the inspection.

It is the Construction Division's responsibility to work with the Project Manager and contractor to rectify noted discrepancies. If after a reasonable time a contractor fails to meet training requirements or ignores requests for corrective actions, the Construction Division, working through the Project Manager, may request suspension of work until corrective action(s) are implemented. Suspending work will be used as a last resort. However, the offending contractor's bidding ability on future contracts could be restricted until such time that compliance with training is demonstrated.

2. Wage Rates

Wage rate interviews may also be completed during the EEO inspection.

- Interviews should be conducted a minimum of every six months for each contractor and subcontractor.
- Projects whose duration is less than six months should have one interview with each contractor and subcontractor.
- Each District must keep interviews on file for three years.

3. Reports

a. "Reimbursable Trainee Training Record"

At the beginning of each calendar month, any contractor or subcontractor having an assignment of annual Training Special Provisions OJT hours for the current year must complete a NDOT Form 298 "Training Special Provision Monthly On-the-Job Training Report" form for each NDOT-let contract for which they had NDOT-approved trainees (NDOT Form 103 "Request for Trainee Approval") perform qualified work during the previous month.

Also, at the beginning of each month, any contractor or subcontractor having an NDOT-let contract assignment of OJT hours must complete a NDOT Form 298 for trainees that performed qualified work on the contract during the previous month.

Copies of completed NDOT Form 298 will be submitted to both the Highway Civil Rights Office and to the Project Manager. The Highway Civil Rights Office will review and tally the hours reported for each contractor, project and trainee. The Project Manager will review the reports and verify the information against available work logs and certified payrolls.

The reporting period for a submitted NDOT Form 298 form will be the preceding calendar month. For example, a NDOT Form 298 submitted on July 1 would report on the hours of qualified OJT work performed by the employee during the month of June. Qualified OJT work is that performed on any NDOT-let contract, whether federally aided or wholly stated funded, and which may be applied to the fulfillment of the requirements of the employee's training.

A copy of the form may be obtained from the Civil Rights page under the Business Center section of the NDOT website. Copies may also be requested from Highway Civil Rights Office.

103.25 WAGES AND EMPLOYMENT

1. In order to comply with the requirements of the Freedom of Information Act regarding protection of personal privacy, all requests for access to certified payroll records shall be forwarded to the Construction Division. Requests must be in writing, and if not made on behalf of an individual, the request must indicate the name of the organization making the request.

2. Access to or copies of payrolls shall not be permitted until authorization has been received from the Construction Division. (Adherence to these procedures during investigation by the Department of Labor or FHWA is not required.)
3. All contracts for highway construction work have certain requirements on wages and conditions of employment. These requirements vary between Federal-aid and State-funded contracts.
4. Some laws or regulations provide specific requirements in the contract documents, while others may be cited by reference. Section 107 of the Standard Specifications requires compliance with all laws and applicable regulations, and accordingly, compliance is required whether or not specific listing or reference is made in the contract.
5. Labor Laws Cited
 - a. Section 107 of the Specifications calls attention to certain State laws and provides that additional regulations and restrictions will be set forth in the special provisions in the contract. These additional regulations are normally included in the required provisions or the special provisions. The enforcement of contract provisions such as these cannot be ignored. However, the inspection, reporting, and enforcement requirements vary between contracts. A basic knowledge of the laws and the exercise of good judgement and diplomacy are required when any enforcement action is taken. Project Managers are advised to contact the Construction Division for decisions on labor complaints for which answers are not readily available. Knowledge concerning these problems is to be handled in confidence, and complete records are a necessity. Certain standard requirements are made a part of all contract provisions. These are as follows:
 - (i) A minimum employment age of sixteen years and the restricting of employment of persons whose age or physical condition is such as to make their employment dangerous to themselves or others.
 - (ii) A provision prohibiting the employment of anyone currently serving sentence to a penal or correction institution (this shall not be interpreted to prohibit the use of persons on a bona fide work release program).
 - (iii) A provision prohibiting discrimination on any grounds against workers who are qualified for the work by training or experience, and who are not disqualified by Paragraphs a. and b.
 - b. These regulations are required by State law, but often are duplicated or made more restrictive by Federal laws.
 - c. *SSHC Section 110* refers to State law restrictions of hours and labor. This would include the State Fair Labor Standards Law which is cited in the Special Provisions in each State-funded project and requires the contractors to comply with such a scale of wages and conditions of employment as are paid and maintained by at least 50 percent of the contractors in the same business or field of endeavor. Contracts for State-funded projects do not contain an established scale of minimum wage rates; however, no wages paid can be below the minimum wage of the Fair Labor Standards Act. Questions which arise concerning the payment

of proper rate should be referred to the District Office, or to the Construction Division (Mike Ondrak, 3830).

103.26 DAVIS-BACON AND RELATED ACTS REQUIREMENTS (Payrolls)

1. General Information

- a. On selected contracts containing Federal-aid funds, Federal laws (Davis-Bacon Act) and regulations require the Secretary of Labor to issue a determination for minimum wage schedules to be included in each of these Federal-aid contracts. Special instructions to the contractors are issued by the Construction Engineer prior to the construction operations. A copy of the current instructions are available at:
<https://www.dol.gov/whd/forms/wh347instr.htm>
- b. Project Managers or their assistants shall conduct wage rate interviews (Report of Labor Compliance Interviews NDOT Form 98) on the selected Federal-aid projects in order to determine whether contractors and subcontractors are properly classifying employees and are complying with the minimum wage rate requirements of the Special Provisions.
- c. The Project Manager is to make systematic spot interviews with the contractor's or subcontractor's employees when he/she feels it is necessary. As a matter of courtesy, the contractor's superintendent or foreman should be advised that personal interviews with employees will be made. The Project Manager shall select the employees to be interviewed and these should be of different payroll classifications if possible.
- d. The number of employees and various classifications to be interviewed shall be at the discretion of the Project Manager to ascertain compliance with these requirements. If violations are discovered, the frequency and number to be interviewed shall be increased and corrective action taken until such violations have been eliminated. Depending on the size of the crews, an attempt should be made to avoid repeating interviews with the same individuals.
- e. Employees should be privately interviewed; that is, without the presence of other employees or their supervisor. The employee being interviewed must not be informed of wage rates reported by fellow employees, but is entitled to know the minimum rates specified for their classification.
- f. Any apparent violations of labor classification or wage rates are to be called to the attention of and discussed with the contractor's or subcontractor's superintendent. In such cases, the Project Manager and the superintendent, considering all the facts and conditions involved, must reach agreement on the proper labor classification. The wage rate paid must be at least the minimum specified for that classification. If a violation in either proper classification or minimum specified wage rate is involved, the contractor or subcontractor shall be directed to correct the classification or wage rate being paid and to make any retroactive payment necessary to provide strict compliance with the requirements.
- g. In all cases of apparent violations of proper classification or minimum wage rates paid, and after the Project Manager and superintendent have reached agreement on the proper classification or minimum wage rate

specified, the employee shall then be contacted and notified as to their proper classification and the minimum wage rate specified for that classification.

- h. If the Project Manager and the superintendent are not able to agree on the proper classification of work performed by the employee, the matter will be submitted through the DCE to the Construction Division Hwy Project Coordinator in charge of labor compliance for guidance. The current Standard Labor Classifications and Descriptions for Highway Construction shall be used in determining the proper classifications.
- i. The interviews shall be recorded on NDOT Form 98, "Report of Labor Compliance Interviews" and transmitted to the District Engineer for review and distribution. The report should be submitted regularly, showing the interview information as found, indicating any apparent existing discrepancies. Information concerning the handling of such discrepancies shall be shown, by means of an appropriate note, on that report or in the subsequent report.
- j. Any classification not covered by the wage determination included in the contract will require the Contractor to initiate Standard Form 1444, "Request for Authorization of Additional Classification and Rate." SF 1444 should be submitted to the Construction Division electronically (Mike.Ondrak@nebraska.gov)
- k. The applicable wage rates to be posted for each individual Federal-aid contract are available in the contract and labor and E.E.O. posters are available on the NDOT website at:
<https://dot.nebraska.gov/business-center/contractor/jobsite-posters/>.
- l. Regardless of the source of funds, highway construction is associated with interstate commerce and, therefore, is covered by the Federal Fair Labor Standards Act. It has specific requirements for payment of a minimum wage rate and time and one-half for overtime over 40 hours in a week, with certain supervisory or administrative employees exempted.
- m. Contractors on selected Federal-aid contracts are permitted to employ trainees and apprentices that are paid below the wage decision included in the contract provided the following information is supplied:
 - (i) Proof of certification by the Department of Transportation for programs other than Nebraska and Iowa A.G.C. training programs.
 - (ii) Proof of registration of trainee in said program.
 - (iii) Proof of the number of previous hours of training the employee has received.
 - (iv) The employees are listed as "trainees" on the payrolls.

2. Payrolls

- a. On selected Federal-aid contracts, the contractor and each subcontractor are required to submit to the Project Manager a certified copy of each weekly payroll and Statement of Compliance - Form WH 348 or a contractor's form with identical wording. The payrolls and Statement of Compliance are to be submitted within seven days after the date the employees are paid. The Project Manager may withhold progress estimates until all delinquent payrolls, with attached Statement of Compliance, have been received. These payrolls may be submitted electronically.
- b. Required Contract Provisions Federal-Aid Construction Contracts - Form FHWA 1273 requires us, as a contracting agency, to perform a certain amount of checking of the submitted payrolls to comply with our oversight responsibilities. The FIRST payroll received from any contractor or subcontractor should be THOROUGHLY checked. (The Project Manager may use some discretion in deferring this thorough check for several weeks, such as in the case when only a few employees appear during the first week or two of a project.) Random checking of all other payrolls is approved.
- c. The Project Manager should check the payrolls for:
 - (i) The employee's full name, mailing address, and Social Security number. (An individually identifying number for each employee (e.g., the last four digits of the employee's social security number) need only appear on the first payroll on which their name appears. The employee's mailing address need only be shown on the first submitted payroll on which the employee's name appears, unless a change of mailing address necessitates a submittal to reflect the new address.)
 - (ii) Each classification, and title must be verified to assure that they are the same (or recognizable abbreviation) as listed in the Contract Wage Rate Decision Schedule, with no deviations permitted.
 - (iii) Each employee's hourly rate must be verified and checked indicating that at least the minimum hourly rate and correct overtime rate has been paid for the listed classification.
 - (iv) All deductions other than the allowable ones are explained.
 - (v) Payroll computation (with the exception of the electronic machine computations) shall be spot checked to verify accuracy.
 - (vi) Payrolls once transmitted to the Project Manager cannot be returned to the contractor for correction of errors. Photocopies of the payrolls may be made and appropriate notes placed on the copies to explain the error(s) to the contractor. The contractor must submit revised certified payrolls or other forms of applicable evidence which provides documentation of the correction(s).
 - (vii) The Project Manager is to retain all payrolls in OnBase until the records are removed in accordance with the record retention

policy. When the payrolls are complete, the Project Manager is to send a letter to the Construction Division Final Review Section in Lincoln, indicating the date the last payroll was received.

- d. Most subsequent payrolls will require only a very cursory review. The Project Manager is encouraged to consider such things as the length of the project and the number of errors encountered on the first thorough examination when determining how many additional thorough payroll checks are performed.
- e. On NDOT Form 84, "Record of Contractor Payrolls Received," the Project Manager should pay particular attention to the column head "Date Received" and to the "Payrolls Completed (Date)". A delay in submittal of payrolls will negate payment of interest on retained monies until receipt by the Project Manager.
- f. According to FHWA 1273, the contractor and subcontractor payrolls are to be retained until three years after the District Engineer is notified by Controller Division that the final vouchers have been submitted to the Federal Highway Administration. OnBase record retention will automatically delete files when appropriate.

3. Interpretation

- a. The interpretation is taken from the U.S. Department of Labor Field Operations Handbook dated March 31, 2016. (A copy of this manual is available [online](#))
- b. Application of labor laws often becomes a matter of interpretation, such as may be involved in instances when furnishing materials must be classified as subcontracting and subject to highway contract labor regulations. This usually applies to labor involved in producing materials from local pits but is not necessarily limited to that operation. The following are examples of elementary rules that may be used in this determination. It is requested that these rules be followed in enforcing the minimum wage requirements of the Special Provisions.
 - (i) The contract labor standards provisions are not normally applicable to employees of "established material suppliers" engaged in the production and delivery of aggregates or materials to the contractor, either to stockpiles or on the road. An "established material supplier" is normally considered to be an aggregate production plant, quarry, concrete plant, or asphalt plant which has been established for commercial production not making more than token amounts of sales to other Federal-aid projects.
 - (ii) When a contractor produces and hauls aggregates for their own use from a previously established pit or quarry from which he/she had been producing and selling aggregates immediately prior to the award of the contract, their production and hauling operations will be considered to be as an "established material supplier" and the minimum wage rates will not apply.
 - (iii) When a new pit or quarry is opened or production equipment is moved into a previously opened pit or quarry for the purpose of

producing material for a specific contract, none of the operations will be considered to be commercial and the minimum wage rates and conditions of employment shall apply to all labor employed in producing and hauling the aggregate to the work.

- (iv) The work of producing or loading material from a local pit shown in the plans, or from a source substituted by the contractor for a local pit shown in the plans, and the work of hauling materials from such sources is considered to be part of the work contemplated in the contract. As such, the minimum wage rates shall apply to all operations performed by the contractor or their subcontractor in processing, loading, and hauling the materials.
- (v) The minimum wage rate requirements do not apply to bona fide owner-operators of trucks who are independent contractors. The certified payrolls including the names of such owner-operators need not show hours worked nor rates allegedly paid, but only the notation "owner-operator".
- (vi) The contractor is required to pay the minimum wage rates to drivers which he/she employs to operate trucks which he/she owns or leases from another party.

4. Apprentices

- a. The contractor is not required to submit the Standard Form 1444 "Request for Authorization of Classification and Rate" for apprentices if verification is received that the employee is registered in a bona fide apprenticeship program.

5. Various outside agencies may request copies of payrolls under The Freedom of Information Act. If you receive a request for copies of payrolls, have the person who is requesting a payroll contact the Communications and Public Policy Division.

103.27 DISADVANTAGED BUSINESS ENTERPRISE (DBE) SUBCONTRACTOR

1. Contract Award

On Federal-Aid projects with predetermined DBE participation goals, all bidders will be required to submit a NDOT Required DBE Participation Form (see bid proposal package) with their bid. This form identifies DBE subcontractors, suppliers, transporters, or manufacturers that the bidder will utilize in attaining the overall contract DBE goal that has been established by NDOT. The DBE Participation Form shall also include a complete description (by item number, group, etc.) of the work that each named DBE subcontractor will perform; and will indicate by dollar amount that portion of each DBE subcontract which the bidder is committing to the attainment of the overall contract DBE goal.

Upon execution of a contract, the prime contractor becomes responsible for attaining the committed amount for each of the DBEs listed on the form, as well as attaining the overall contract goal. This is a contractual arrangement between the State and the prime contractor with the same enforcement as any other provision specified in the contract documents. A prime contractor is required to enter into a contractual arrangement with each DBE listed by formally executing a written subcontract agreement specifying the work to be performed and

appropriate compensation for that work. This two-tier process, which contractually obligates the prime contractor to both the State and each participating DBE, formalizes implementation of all DBE contract provisions.

The Highway Civil Rights Office will review the low bidder's NDOT Required DBE Participation Form to assure that the firms utilized in attaining the overall contract DBE goal will be performing work of a type for which they are DBE certified. The successful bidder must then submit a letter and copy of each DBE Subcontract to the Construction Division to have those subcontractors approved.

2. Commercially Useful Function (CUF) and Counting of DBE Participation

General guidelines regarding DBE CUF and counting of participation are provided below. Complete guidelines may be found in the NDOT DBE Program Plan under the section *Monitoring and Enforcement of Program Requirements*. A copy of the program plan may be found on the Civil Rights page of the NDOT website, or may be obtained upon request from the Highway Civil Rights Office (HCRO).

Questions regarding the rules of CUF and counting should be directed to the HCRO. In all cases where there is a question regarding the commercially useful function of a DBE and the counting of work performed by a DBE, the HCRO must be notified.

- a. The NDOT will count expenditures to a DBE contractor as being participation toward a DBE project goal or commitment only if the DBE is performing a commercially useful function (CUF) on a contract.
- b. The NDOT evaluates CUF on a project by project basis. A DBE performs a CUF when it is responsible for the execution of work in its contract and carries out its responsibilities by actually performing, managing and supervising the work using its own personnel and using equipment it owns or holds under long-term lease. The DBE must also be responsible, with respect to materials and supplies used on the contract, for negotiating price, determining quality and quantity, ordering the material, and installing (where applicable) and paying for the material itself.

Examples of considerations made in determining whether a DBE is performing a CUF may include, but are not limited to, the following:

- The DBE firm manages the work contracted. Management includes scheduling work operations; ordering equipment and materials (if materials are part of the contract); preparing and submitting payrolls and all other required reports and forms; and the hiring and firing of employees, including supervisory employees.
- The DBE performs work with employees normally employed by and under the DBE's control, and the DBE is responsible for the payroll and labor compliance requirements for those workers.

NOTE: DBEs may, if a need can be demonstrated and prior approval is received from the NDOT Highway Civil Rights Office, use other means to perform work on a limited basis when the contract requires specialized knowledge, skills, or equipment; and

may be allowed to augment their work force on a limited basis with personnel which normally work for another firm, but only.

- The DBE owner or a skilled and knowledgeable superintendent employed and paid wages by the DBE is at all times directly supervising the performance of the firm's portion of contracted work, and all the administrative functions of the firm are performed by employees of, or duly authorized agents responsible to, the DBE. The DBE owner is at all times actively engaged in and exercises full authority over the daily operations of the firm.

- c. Further, in determining whether a DBE is performing a commercially useful function, the NDOT will evaluate the type and amount of work contracted in relation to accepted industry practices and whether the amount the DBE firm is to be paid is commensurate with the work actually performed; and will evaluate the DBE participation credit claimed for performance of the work. The NDOT will consider and evaluate other relevant factors as may be applied in the circumstances.

Accepted industry practices will be determined by NDOT project managers, engineers, planners, purchasing agents, and other staff having knowledge and expertise related to the area in question.

- d. The NDOT will count expenditures to a DBE toward DBE goals and commitments.

- e. Partial Subcontract of an Item

It is not unusual for DBE subcontractors to be involved in only part of a contract item.

For conditions where a subcontract does not exist but a DBE firm is manufacturing, supplying, or trucking materials to the job site, this dollar value will not be used to determine the percent subcontracted as specified in the *Specifications*.

Inspection staff must monitor work performed and periodically inform the Project Manager as to which individuals and equipment actually worked so payrolls can be spot-checked.

3. Construction Period

The Project Manager and inspectors must review work subcontracted to DBE subcontractors to assure work is being performed and that DBEs are performing a commercially useful function. Where work is performed by any other contractor or with equipment not owned by the DBE, the inspector shall issue a noncompliance notice citing violation of *Supplemental Specifications for Specific Affirmative Action Responsibilities*. This noncompliance shall be immediately reported to the Project Manager, who will in turn immediately notify the Highway Civil Rights Office.

Prime contractors will be given credit toward the DBE contract goal only when a DBE performs a commercially useful function. The requirements for a commercially useful function are outlined in the previous section "Subcontract Approval."

A DBE may lease equipment consistent with standard industry practice provided a rental agreement specifying the terms of the lease arrangement is approved prior to a DBE starting work. If equipment is of a specialized nature, the lease may include an equipment operator. No credit will be given for the cost of equipment leased or rented from the prime contractor.

DBEs shall negotiate cost, arrange for delivery, and pay for materials and supplies required for their portion of the contract work. Invoices for materials shall be invoiced to the DBE firm and not to a prime contractor.

A prime contractor may occasionally find it necessary to ensure that payments are made to suppliers for materials used by subcontractors. When such a joint check payment arrangement is pre-approved by the Highway Civil Rights Coordinator, counting the cost of materials actually incorporated into the project by a DBE subcontractor toward DBE participation will be allowable provided the DBE:

- orders and schedules the delivery of materials, and
- is fully responsible for ensuring that materials meet Specifications.

When the Highway Civil Rights office approves such payments to be made by the prime contractor, payments must be made by preparing jointly endorsed checks signed by the DBE and supplier.

No credit shall be allowed toward the DBE goal for cost of materials placed by a DBE subcontractor when payment is made by deducting this payment from the prime contractor's payment to the DBE.

Project Managers must evaluate and document performance of the DBE's activity on all projects as part of the normal project contract compliance monitoring. On-site project monitoring by field personnel shall include employee assignments, equipment used, and supervision of the work. All irregularities must be documented in the field books and immediately reported to the prime contractor, and the Contract Compliance Officer in the Highway Civil Rights Office.

Project Managers shall not allow a prime contractor or another contractor to perform work that has been committed to a DBE subcontractor without prior written approval from the Highway Civil Rights Office.

In situations where a DBE subcontractor cannot (or is not) performing, the prime contractor must follow all steps described in *Supplemental Specification for Specific Affirmative Action Responsibilities*. Upon receipt of a signed statement from the DBE and documentation where the prime contractor will satisfy the goal with other items or DBEs, the Project Manager may recommend to the Highway Civil Rights Office that the commitment be waived and the required goal adjusted. The Highway Civil Rights Office must provide written approval of all substitutions before any changes in subcontracted work are performed.

4. Post Construction

Prime contractors shall submit a completed "Identification of DBE Goal Achievement" (NDOT Form 441) with the final project documents to the Highway Civil Rights office. The subcontractor submits NDOT Form 442 "Identification of Work Performed." Blank forms are provided in the website. These forms certify the dollar amount paid to each DBE. Highway Civil Rights Office must compare

the dollar amounts on Forms 441 and 442 to dollar amounts committed to a DBE on "Required DBE Participation Form." The prime contractor will be assessed a penalty by change order for failure to satisfy the DBE commitments. This penalty may be reduced when conditions described in *Supplemental Specification for Affirmative Action Responsibilities* are satisfied. Project Managers must include a written explanation describing situations, background, and findings which resulted in reductions or adjustments.

Unique problems have been noted with the goals and variables of the DBE program. Documentation of any activity related to the program is important and must not be overlooked. Record all telephone or personal contacts noting time, place, and details.

103.28 LEASE OF PROPERTY BEYOND THE HIGHWAY RIGHT-OF-WAY

The NDOT has found that it is more cost effective and quicker to have the contractor make most land use agreements for areas outside the highway right-of-way. This means borrow sites, plant sites, storage areas, parking lots, and so forth are the contractor's responsibility to lease.

103.29 CONTRACTOR'S USE OF HIGHWAY RIGHT OF WAY

Occasionally a contractor requests permission to establish a plant site or a material stockpile on highway right-of-way. In reviewing these requests, the District Engineer must consider the impact of vehicles (trucks or equipment) entering and leaving these sites on public traffic. In situations where these vehicles must enter an open ramp or lane at a point where access is not allowed to the general public, the request shall normally be denied. On two-lane roads if an access permit can be obtained and public convenience and safety is not adversely affected, the request may be approved. On closed sections of the highway, right of way may be used as long as trucks can enter and leave the closed road safely.

Many times a contractor will have to exit a controlled-access facility to deliver materials such as mulch, subdrain, guardrail, etc. These stockpiles may be allowed as long as the material is to be used in the general vicinity where stockpiled and is stored beyond the "clear zone".

103.30 CONTRACT QUANTITIES

The Project Manager and the contractor may agree to a final payment for an item based on contract quantities, i.e., plan quantity. The Project Manager shall verify that the plan quantities are reasonably accurate.

Final review corrections should be limited to errors of \$150.00 or more per pay item. Do not waste time and money making small corrections.

103.31 CONTRACTOR'S SALES TAX EXEMPTION

When a NDOT contract is awarded, the Contracts Section of the Construction Division will issue the prime contractor a "Purchasing Agent Appointment" and an "Exempt Sale Certificate for Contracts". These forms allow the contractor to purchase materials that are to be incorporated into a highway project without paying any sales tax. The prime contractor is allowed to make copies of both forms and provide them to the project subcontractors for their use. The prime contractor must contact the Contracts Section [(402) 479-4851] to obtain an extension. The Contracts Section completes the extension by issuing a new "Purchasing Agent Appointment".

103.32 EMAIL – NOTIFICATION

Field personnel are strongly encouraged to open their electronic mail daily. The Construction Division (and others) use it regularly and expect messages sent to be messages read.

Any time a plan error/omission is discovered or if for any reason the contract must be changed, the PM should send an email with appropriate details to the designer (Bridge or Roadway), Construction Division, and if necessary, to Materials & Research.

103.33 PRIME CONTRACTORS/SUBCONTRACTORS

Project Managers should be reminded that correspondence pertaining to a subcontractor should be directed to the prime contractor.

103.40 FREIGHT RATES

Nebraska does not regulate freight rates on bulk-containerized materials like cement, fly ash, and asphalt cement; and, therefore, the Construction Division will not make freight rate adjustments.

103.50 BARRICADES, DANGER, WARNING, AND DETOUR SIGNS

SSHC Subsection 107.07 provides for furnishing, erection, and maintenance of necessary barricades, lights, signs, and watchpersons, in accordance with the latest edition of the [Manual on Uniform Traffic Control Devices for Streets and Highways](#) (each Project Manager should have a copy) and taking necessary precautions for the protection of the work and safety of the public by the contractor. The contractor must erect advance warning signs for traffic hazards created by their operations, and at points where the work crosses or coincides with an existing road, in accordance with the plan requirements.

Signs which have been furnished to the contractor at no cost for placement on projects under construction must be returned to the appropriate NDOT location in reusable condition when they are no longer needed. A charge will be made to the contractor for the value of signs damaged or not returned. The office issuing the sign will determine the charge for damage or loss.

103.60 SAFETY AND HEALTH REGULATIONS FOR CONSTRUCTION

Nebraska provides job safety and health protection for all workers throughout the State of Nebraska.

The Labor Department is responsible for administering safety policy. The Nebraska Labor Department adopts federal occupational safety and health standards as State of Nebraska standards. Employers and employees are required to comply with these standards. The OSHA requirements are enforced by the Federal Government. The Nebraska Department of Labor will, upon request, conduct consultation visits of the job site.

103.61 RESPONSIBILITY OF CONTRACTOR

Contractors shall be responsible for initiating, maintaining, and supervising all safety precautions and programs for their employees in connection with the work. Furthermore, contractors are responsible to provide a safe work site for NDOT employees.

Safety Inspections

The contractor may conduct safety inspections at the start of all major phases of the project.

Postings

The contractor is required to have four documents regarding safety posted on the project bulletin board:

- Job Safety & Health Protection (OSHA 2203)
- "Log and Summary of Occupational Injury and Illnesses" Poster (OSHA Form 200) (11 or more employees)
- Emergency Action Fire Prevention Plan.
- Emergency Phone Numbers (i.e., 911, Poison Control, etc.).

Checklist Safety Program

- Does the contractor have a definite safety program?
- Does the program have the active and continued support of company management?
- Has responsibility for safety been assigned to a specific top company official? Is there a staff for full time safety work?
- Does the contractor know the governmental safety regulations and consider carefully the cost of safety in bidding and executing the work under contracts?
- In dealing with labor, subcontractors, and material and equipment suppliers, does the contractor make clear the safety responsibilities and requirements to be met?
- Does the contractor make frequent safety inspections of operations on the project? Does this include subcontractor operations?
- Does the contractor train their employees to recognize and to avoid unsafe conditions and practices related to their individual work assignments?
- Are all accidents investigated, recorded, and reported?
- Does the contractor keep in touch with responsible officials and organizations concerned with standards and with enforcement of occupational safety and health requirements?

This checklist may be used when discussing Safety at the pre-construction conference.

104.00 CONSTRUCTION INSPECTION

104.01 CONTRACT TIME DETERMINATION (*SSHC Subsection 108.02*)

Tentative Start Date - The proposal will show a tentative date on which it is anticipated that the contractor may begin operations.

In most cases, the tentative start dates are established several weeks in advance of the letting date by determining the latest possible date the Department would like to see the work completed and backing out the estimated number of days required to complete the work. Consequently, any requests to delay the start of work on a project are thoroughly examined before being approved. Additionally, the approval to delay the start of on a project may be made contingent upon certain concessions by the contractor (such as the imposition of a disincentive payment for a late completion).

In the case of contracts involving multiple time allowances, extensive utility relocation, or work to be performed by others (e.g., railroads, cities, counties), it may be necessary to delay the start of work for several weeks after the tentative starting dates shown in the proposal.

If the tentative beginning date shown in the proposal appears to be earlier or later than believed possible or practical due to job, weather, traffic, or other conditions relevant to the project, the Construction Engineer should be notified promptly.

Work Authorized to Begin Date - The date established in the NTP letter authorizing any project work performed by any contractor as defined in SSHC (2017) 108.02 paragraph 3a and 4a. to be performed on the project without the charge of Working/Calendar days. The Construction Division verifies that the contractor's insurance is valid for the type of work the contractor requests to perform.

Notice to Proceed - The contractor will be given a Notice to Proceed by the Construction Division, and work should not begin until the notice has been issued by the Construction Division.

Normally, the Notice to Proceed Date will coincide with the Tentative Start Date shown in the proposal. The Notice to Proceed letter/email will automatically be issued after the contract is in place, usually a week or two prior to the starting date unless a request for a revised start date has been received from the contractor.

It should be noted that in SiteManager, the Notice to Proceed Date is recorded in SiteManager under "Key Dates" as the "Notice for Work to Begin" date.

SiteManager's "Notice to Proceed Date" is actually the contract execution date. It is located in the "Critical Dates" tab in SiteManager and is used by Construction Division to activate the contract options in SiteManager. Do not alter any "Critical Dates".

Requests to begin work prior to the tentative start date should be made by the contractor directly to the Construction Engineer in Lincoln to:

NDOT.ContractStartDate@nebraska.gov.

In some cases, such requests are made following issuance of the original Notice to Proceed Letter/email. If the request is approved, a revised Notice to Proceed Date will be issued.

Requests to begin work after the tentative start date shown in the proposal should be made by the contractor to the Construction Engineer in Lincoln (to NDOT.ContractStartDate@nebraska.gov), *prior* to the tentative start date shown in the proposal.

Beginning the Counting of Working Days - The counting of working days or calendar days must begin on the date established in the written Notice to Proceed or on the actual beginning date, whichever is earlier. Accordingly, working day report entries should be made beginning with the established beginning date or actual beginning date – whichever occurs first. Entries should continue for each and every day (seven days per

week) until the project has been tentatively accepted. Reports may be suspended when the work is suspended for an extended period.

Under specified conditions, some items of work may be performed for which working days or calendar days will not be charged. Even under these circumstances, however, working day reports must be created to document that work was performed without the charge of working days or calendar days. Work subject to this rule is listed in *SSHC Subsection 108.02*.

If a working day is not assessed, the Project Manager is required to select a 'No Charge' reason code in SiteManager from one of the options below:

ADMR	Admin Relief -Central Office Use Only
COCO	Contract Conditions – this option is to be used when referencing a contract provision (including change order/supplemental agreements, work orders, etc.)
CURE	Cure Time
ESTP	Establishment Period
HLDY	Holiday
MBTA	Migratory Bird Treaty Act Avoidance Measures
MINR	Minor Work, according to the SSHC
OBSP	Observation Period
PMEO	Documentation - PM Diary Entry Only
QADJ	Quantity Adjustments
RWNC	Restoration Work
SOIL	Soil Conditions
SPCO	Special Project Conditions – this option is to be used for an unforeseen occurrence on the project
TSOW	Temporary Suspension of Work
WKND	Weekend
WTHR	Weather Conditions
WWSP	Winter Work Specifications as per the contract

Calendar Day - *SSHC Subsection 101.0314* gives the definition of a calendar day.

Working Day - *SSHC Subsection 101.0410* gives the definition of a working day.

Current Controlling Operation - *SSHC Subsection 101.0326* gives the definition of the current controlling operation.

While the counting of calendar days is quite straightforward and is usually dependent only on the passage of time, the counting of working days requires a determination of the current controlling operation. A basic test for the determining the current controlling operation on any given day is whether or not the non-performance of that operation will delay the completion of the work.

The contractor's project schedule can be a very useful tool in determining the current controlling operation. The specifications require that the critical path activities be shown on the schedule; and those activities, in essence, are the controlling activities. Because the specifications allow several types of schedules and because contractors possess varying degrees of skill in preparing the progress schedule, it is strongly recommended that the Project Manager and Project Superintendent discuss the project schedule and come to some mutual agreement concerning the path of critical activities - as may be the case when a bar graph shows several activities occurring at the same time.

The contractor has the right to object to the charge of working days, and those kinds of objections will be minimized if there is an "up front" agreement regarding the controlling operation. There usually will be little dispute regarding whether or not the work was performed.

The current controlling operation should be shown in the Project Manager's diary and on the working day reports. Any discussions or agreements with the contractor regarding it should also be documented in the diary. The assessment of working days is a very important task for the Project Manager, but should not be considered extremely difficult. Common sense and fairness should prevail.

Following are the basic criteria for determining the charging of working days:

1. Weekdays, Monday through Friday, except for Martin Luther King Day, Presidents' Day, Arbor Day, Columbus Day, and Veterans Day, are to be counted as working days whether the contractor works or not if he/she is not prevented by weather, soil conditions beyond their control from proceeding on the current controlling operation for at least 50 percent of the hours in a normal schedule with 80 percent of the normal work force. Martin Luther King Day, Presidents' Day, Arbor Day, Columbus Day, and Veterans Day regardless of whether or not the contractor works are never counted as working days.
2. Saturdays will not be counted as working days, except for certain cases when New Year's Day, Independence Day, and Christmas Day fall on Saturday and the contractor works (any work) **and** inspection or engineering work by the Department is required.
3. Sundays will not be counted as working days unless the contractor works (any work) **and** inspection or engineering work by the Department is required.
4. New Year's Day, Memorial Day, Independence Day, Monday July 3 or Friday, July 5, Labor Day, Thanksgiving Day, the day after Thanksgiving Day, and Christmas Day will not be counted as a working day unless the contractor works (any work) **and** inspection or engineering work by the Department is required.

It is emphasized that if the Project Manager does not count working days because of delays "beyond the contractor's control", the situation involved should be clearly beyond the contractor's control. The Project Manager should be thoroughly familiar with the provisions of Specification 108.02. For example, Paragraph 8 provides consideration will not be given to possible "loss of efficiency" due to prosecution of the work during the winter months in the charging of working days when the special provisions require performance of work during cold weather periods. The following example illustrates the application of this provision:

On a clear, cold day in January, a pile-driving operation may be 80 percent as efficient as it would be on a fair, warm day in July. Under this provision, a working day would be counted against the current controlling pile-driving operation even though the relative efficiency of the operation was reduced. When bidding on work that is to be accomplished during the winter months, the contractor is presumed to have accounted for the loss of efficiency. However, if sufficient snowfall or extremes of wind or temperature make it physically impractical to prosecute the pile driving operations, working days would not be counted under such conditions.

Shortages of material delaying prosecution of the controlling operation would not normally be considered beyond the contractor's control. Unusual, extensive, or industry-wide situations (strikes, transportation tie-up conditions, industry-wide shortages) may

constitute delays beyond the contractor's control if the contractor has used due care and planning in ordering and scheduling delivery of the materials.

The Project Manager investigates and determines when shortages of materials are beyond the contractor's control.

Shortages of labor are specifically eliminated as justification for an extension of time (*SSHC Subsection 108.02, Paragraph 9*).

SSHC Subsection 108.05 requires the contractor to employ sufficient equipment of adequate size and in such mechanical condition as to meet the requirements of the work. Accordingly, delays resulting from breakdown or malfunction of the contractor's equipment are not considered to be beyond the contractor's control.

Working Day Report and Diary Record - *SSHC Subsection 108.02, Paragraph 5* provides that Engineer (Construction Division) will make available on the Department's website the weekly report of working days. These reports are generated, compiled posted to the website at mid-week, so it is very important that the working day information is entered promptly following the completion of the week's work. Special efforts should be made to impress upon consultants employed by the Department or other governmental agencies that they must submit their working day report information without delay at the beginning of each week.

In addition to our contractual requirement to make available the working day report to the contractor, these reports are reviewed by one or more individuals in the central office. The following information should be accurately recorded in SiteManager in order to be included on each weekly working day report:

- Notice to Proceed date (Notice for Work to Begin)
- Work Authorized to Begin date
- Actual starting date (Contractor Actually Started Work)
- Current Controlling Operation
- Hours Worked on the CCO
- Hours worked on non-CCO work if CCO hours are zero
- Reason for charge or non-charge of a day if the charge is not what might normally be expected. (Such comments must be entered into the "CCO" field in SiteManager to be visible on the report.)

It is the contractor's obligation to review the working day report when it is received and promptly file any objections to it. The Project Manager is obligated to promptly review the objections and rule on their validity. When such reviews are delayed until the project is complete, there is too great a risk that the details affecting the decision can be forgotten. Whatever the result, the decision should be documented either by letter (preferably) or diary entry when the objection is denied or by the issuance of a Time Extension Document when an adjustment to the time allowance is justified.

Although the contractor is required to file an objection to the working day count within 14 days, claims often fail to surface until the latter stages of a job when the remaining working days are few. For this reason, it is especially important that a complete and accurate diary record be maintained. For purposes of making the initial assessment of working days and any subsequent review the following information, if applicable, should be recorded or documented daily in the Project Manager's diary:

1. The current controlling operation
2. The weather
3. The work performed
4. Unusual or adverse weather or soil conditions encountered
5. Other unusual occurrences impacting work on the project
6. The times that major work operations halted and resumed and the reasons why
7. Changes in the work force effecting work on the controlling operation
8. Major deviations from the contractor's approved progress schedule
9. Conversations pertaining to any of the above

The need for this information isn't always apparent until the work is completed or until a request has been made for reconsideration of the charging of working days.

104.02 CHARACTER OF WORKPERSONS, METHODS, AND EQUIPMENT

The Project Manager may have the contractor remove intemperate or incompetent superintendents or workers (*SSHC Subsection 108.05*). The PM may also order the removal of unsatisfactory equipment (*SSHC Subsection 107.01*). However, the contractor should be given complete latitude in the supervision, methods, and equipment used in performing the work unless the specifications specifically prescribe the methods and equipment to be used.

104.03 TEMPORARY SUSPENSION OF WORK (*SSHC Section 108*)

Specification Provisions - If weather or other conditions are such as to clearly determine the unsuitability of prosecution of the work for more than two weeks, the Project Manager should discuss the situation with the District Construction Engineer, and with their approval, temporarily suspend the work and the counting of working days. The working day report should be clearly marked "Work Temporarily Suspended". The condition or situation which makes the suspension necessary should be briefly described under "Explanation of Delays" in the report which will constitute the written order suspending the work. The term or estimated length of suspension should be included in the explanation. Typical explanations are listed:

1. "Bituminous base (or mat) surface course operations and working day reports are suspended because of lateness of season. The consideration of working days resume approximately (date) with the return of weather conditions favorable to the prosecution of this work."
2. "Grading operations and working day reports suspended until approximately (date) when progress of the bridge work will permit backfilling and finishing around the structures."
3. "Bridge operations and working day reports suspended until approximately (date) when progress of grading work will permit construction of concrete approach slabs and guard rail at the bridge locations."
4. **Winter Work Provision:** When the contract includes special provisions allowing work through the winter without the charging of working days, reports must be submitted showing the hours the contractor worked even though working days are not charged. If the contractor suspends operations on the project, reports may be suspended; but they must resume on the date specified in the special

provisions for the end of the winter work season or when the contractor resumes work, whichever is first.

Specialized Work Items, Time Suspensions - There have been inquiries regarding the propriety of temporarily suspending the work for short or limited periods of time, in the performance of minor, specialized work items which are usually performed by subcontractors or specialized personnel or technicians, rather than with the contractor's own forces.

It is recognized that at times the contractor may have difficulty in getting the specialized personnel or subcontractor, skilled in performing minor specialized items of work, to schedule and perform such work precisely when the site is available. Accordingly, it is considered proper to authorize a temporary suspension of the work in such cases, subject to the following:

1. The work is minor, specialized work, which is to be performed by specialized forces rather than the usual work forces.
2. The suspension will be for a limited, reasonable length of time; that such suspension will not adversely affect the scheduled use of the completed facility by the state; and that the suspension will not delay the work of any other contractor.
3. The contractor should make written request for such suspension to the Project Manager, listing the reasons for and the length of the proposed suspension.

The Project Manager should discuss the matter with the District Construction Engineer and may, with their approval, make such temporary suspension of the work, subject to meeting the conditions listed above.

104.04 PROGRESS OF WORK (SSHC Subsection 108.07)

The Project Manager should monitor the contractor's progress in relation to their progress schedule and the requirements of *SSHC Subsection 108.07*. If a contractor's progress falls seriously behind the schedule necessary to complete the work in the allotted time, the Project Manager and the District Construction Engineer should review the possible causes for this situation. If the contractor's progress is behind in proportion to the working days charged, one of the three conditions listed will probably be the cause.

1. Working days are being improperly charged. Weather or other adverse conditions or conditions beyond the contractor's control may be preventing the contractor from working with 80 percent of forces or from working on the controlling operation. If work days appear to have been improperly charged, the matter should be discussed with the Project Manager; and, if necessary, the Project Manager's diary should be revised to correct the working days charged.
2. Work is being delayed by causes beyond the contractor's control. If this is true, it should be documented by letter from the contractor and also in field records (diary). The District Construction Engineer must approve an extension in the time allowance.
3. The contractor is not prosecuting the work with sufficient forces and equipment to complete the contract within the specified time allowance.

Progress may be considered not satisfactory if the work falls behind (rule of thumb is 10 percent) the contractor's work schedule. At this point the PM should request a new schedule that demonstrates how the contractor plans to complete the work within the allotted contract time allowance. When the contractor's schedule (or the DCE's assessment of anticipated progress) does not indicate completion within the allotted time allowance and condition three appears to be the cause, the District Construction Engineer will notify the contractor in writing of seriousness of the issue and steps the State could take to expedite completion of the work in a satisfactory manner.

104.05 WINTER WORK (Special Provision)

Determination of contract working days charged during the winter is made according to the rules set forth in the Specifications unless the proposal contains what is commonly referred to as the Winter Work Provisions. This special provision will generally permit the contractor to work without the charge of days during the months of December, January, February, and March. (Days near December 1 and March 31 may be selected to delimit the period so that the affected period of time begins and ends on a Sunday or Saturday, respectively.)

The "winter work" provisions are usually included in contracts where the Department anticipates work to carry over from one construction season to the next. They may be added to a contract by preparing a supplemental agreement to that affect, but they should not be added automatically. For example, a contractor should not be rewarded with the winter work provisions when he or she has failed to complete a project as scheduled because of inadequate prosecution of the work.

On the other hand, a contractor desiring to start a project early or a contractor delayed for reasons beyond his or her control may be granted the winter work provisions as an encouragement to pursue the work.

The Project Manager may require the contractor to place temporary materials prior to a suspension in the following situations:

- A project (or a required intermediate portion) is not completed within the allowed contract time, **and**
- Work continues (or is required) after November 30th, **and**
- Due to weather conditions, work cannot be completed.

Typically, temporary materials will be required for safety or soil erosion considerations. All temporary materials shall be furnished, placed, and removed (if required) prior to start-up at the contractor's expense.

Project Suspensions

If work is suspended, with approval of the District Engineer, working days would not be charged.

104.06 WEEKLY REPORT OF WORKING DAYS

Working day reports are maintained in and generated by SiteManager.

104.07 RENTAL RATE GUIDELINES (*SSHC Subsection 109.05 and Section 919*)

Contractor-Owned Equipment

The following guidelines apply to the determination of rental rates for contractor-owned equipment used on an “extra work” basis.

1. a. The *Rental Rate Blue Book for Construction Equipment* should be used to determine the hourly rental rate of the equipment in question.
- b. In order to determine the proper rental rate, equipment should be identified as completely as possible (make, model, year of manufacture). When practical to do so, it may prove helpful to examine the *Blue Book* before beginning the task of identifying the equipment. Such an examination may lend some insight into the identifying characteristics of the equipment (such as bucket capacity, horsepower, fuel type, etc.) and the potential equipment attachments that may qualify for additional payment.
- c. The *Serial Number Guide for Used Construction Equipment* may be helpful in identifying the age of a piece of equipment.
2. The hourly rental rate shall be calculated by dividing the monthly rental rate shown in the *Blue Book*, including that of attachments actually used, by 176.
3. The hourly rental rate shall be:
 - a. increased or decreased by the regional/climatic ownership factor published in the *Blue Book*. The *Blue Book* publishes an individual table in each section showing the adjustment factor for each state. The tables showing the regional/climatic factors are usually located at the beginning of each section with other rate adjustment tables.
 - b. decreased (or allowed to remain the same) by the age factor found in the *Blue Book*. (See 1.c. above)
4. The estimated hourly operating costs, including those of attachments used in the prosecution of the work, shall be determined from the information shown in the *Blue Book*. Adjustments due to age or regional/climatic conditions ARE NOT applied to the estimated hourly operating costs.
5. a. The total hourly rate (sum of adjusted hourly rate and estimated operating costs) shall be increased by 15% to compensate the contractor for overhead and profit. (See “Additional Considerations”)
6. a. Equipment operators, when applicable, shall be compensated according to the rules set forth in the *Specifications*, average hourly wages being calculated by dividing the total hours worked during the week, including overtime, into the gross wages earned during the week.
- b. Equipment may be shown as “fully operated” by adding an amount equal to 150% of the operator’s average hourly wage to the rental rate. When this method is chosen, the equipment rate will be eligible for the additional 15% for overhead and profit; the adjusted operator’s rate is not.
7. a. The number of hours of “equipment rental” for which payment will be made for each item of equipment must be determined on a case-by-case basis.

- b. In general, when equipment is already on the project, payment hours shall be limited to the actual hours of use, with no deductions being made for minor interruptions of the work. If the equipment has been dedicated to another operation and was actively being used in that operation when it was reassigned to the “extra work”, consideration may be given to paying for “standby time” for idle periods exceeding two consecutive hours which are not the fault of the contractor.

Rented or Leased Equipment

The following guidelines apply to the determination of rental rates for rented or leased equipment used on an “extra work” basis.

1. When it becomes necessary for the contractor to rent or lease equipment to complete extra work, the contractor shall be compensated 115% of the actual invoice cost of the rented or leased equipment. This procedure provides compensation for overhead and profit.
2. a. The rental or lease rate shown on the invoice may be compared to rates published in the *AED Green Book* to determine if it is reasonable.
3. Because the estimated hourly operating costs shown in the *Blue Book* include costs associated with the maintenance and replacement of items such as tires, pumps, and other components which are the responsibility of the owner, the operating costs shown in the *Blue Book* shall not be included for payment. However, if the contractor itemizes and documents the daily costs incurred for fuel, lubricants, etc., those costs can be included for payment.
4. a. Equipment operators, when applicable, shall be compensated accordingly to rules set forth in the *Specifications*, average hourly wages being calculated by dividing the total hours worked during the week, including overtime, into the gross wages earned during the week.
b. In some cases, where the invoice provides a convenient way to do so, equipment may be shown as “fully operated” by adding an amount equal to 150% of the operator’s average hourly wage to the rental rate.

Additional Considerations

1. Mobilization
 - a. If the equipment needed to perform extra work is not located on the project, the contractor is entitled to compensation for mobilizing and demobilizing the equipment. Labor and hauling equipment used to transport the equipment to and from the project is eligible for compensation. The equipment needed for the extra work is eligible for compensation at “standby” rates if it is transported during normal working hours.
 - b. Reasonable costs associated with readying the equipment for transport (assembly and disassembly) shall also be allowed.

2. Standby Time

- a. If the contractor is required to idle equipment engaged on “extra work” and the equipment was:
 - (i) already located on the project site and engaged in other productive activities, or
 - (ii) brought onto the project for the specific purpose of performing extra work, he/she may be entitled to compensation for “standby time”. The equipment must be idled due to reasons beyond the contractor’s control and not be used for the performance of other work.
- b. When payment for standby time is justified, payment for the idle hours should be made at one-half of the established rental rate (excluding estimated operating costs).
- c. Additional compensation for overhead and profit shall not be made for any equipment considered to be “on standby”.
- d. Operators of idled equipment are eligible for compensation according to the procedures previously described provided they are not reassigned to other duties or taken off the payroll.
- e. The sum of “active” and “standby” time for any piece of equipment or its operator will generally be limited to 8 hours per day, but must be monitored to insure that an unreasonable limitation is not placed on the standby hours. For example, if a piece of machinery is utilized from 8:00 to noon, stops for lunch until 12:30, and then resumes working until 2:30 when an unavoidable delay stops activity on the “extra work” until the next morning, the standby time should be limited to 2 hours the hours which would have been utilized to complete an 8-hour day.

3. Reconciliation of Records

It is highly recommended that the Department’s records and the contractor’s records of labor, equipment, and materials used on any “extra work” be compared, reconciled, and documented daily.

104.08 CHANGE ORDER - SUPPLEMENTAL AGREEMENTS

(SSHC Subsection 104.02)

Change Orders are used to:

- Change the authorized quantity of a contract item. This includes increases, decreases, or deletions to contract quantities.
- Add a new item or material to an existing contract. Often this is a result of plan revisions or a change in scope from what was originally envisioned at time of letting.
- Serve as a source document for the Controller Office.
- Officially document changes to the contract documents. CO/SAs and work orders are written orders to a prime contractor which are initiated and prepared by the Project Manager. Once signed by all parties, these documents become a legally binding part of the contract ordering a specific change to the original contract.

Policy for Change Orders

1. Contractor Markup

Subcontracted Items. Extra work performed by a subcontractor entitles a prime contractor an allowance to cover administration expenses. This markup is not to apply to incentive payments. The percentage allowed for administration expense is discussed in *SSHC Subsection 109.05*.

Contract Unit Price. Change orders covering an overrun/underrun (*SSHC Subsection 104.02*) of items at contract unit prices are NOT eligible for any additive like an allowance for administration expenses. This includes work which was done by a subcontractor. The contract unit price should have already considered any necessary additives for administrative expenses.

The contractor may request a change order when additional work differs materially in kind or nature from the work included in the originally proposed construction.

A major item of work is defined as an item whose total original contract cost exceeds 10 percent of its original group total amount. The price for a pay item may require adjustment when a major item is increased in excess of 125 percent or decreased below 75 percent of the original contract quantity. Any allowance for an increase in quantity shall apply only to that portion in excess of 125 percent of the original contract item quantity, or in case of a decrease below 75 percent, to the actual amount of work performed.

A contractor may request a price adjustment to recover lost administration expense for underruns amounting to more than 25 percent of the bid amount for a major item of work. A contractor is allowed to recover only that portion of lost administration expense represented by the underrun.

By the same reasoning, a like price adjustment may be made to reduce the cost of major items of work which overrun by more than 25 percent, since the contractor should have already included overhead expenses in their bid. Overrun price adjustments apply to only that portion/quantity which is more than 125 percent.

Agreed Unit Price. Extra work orders based on an agreed price or lump sum should have overhead considered as a part of the negotiation. The agreed unit price may include the cost of overhead for handling subcontracted items. It may be included in lump sum items if justified. However, if negotiations specifically excluded markup, the item may be shown as a separate entry on a cost work up sheet.

Force Account. (*SSHC Subsection 109.05*) Specified force account percentages for labor and material are intended to cover all costs that a contractor may incur due to the work, regardless of who does that work (prime or subcontractor). Force account work to a subcontractor will be authorized for additional administration percentage to a prime.

Plan Revisions

Often, plan revisions result in Change Orders having to be negotiated. Processing Change Orders resulting from plan revisions is sometimes delayed due to disagreement on prices, lack of success in obtaining qualified subcontractor(s), or various other reasons.

It is imperative that Project Managers actively pursue Change Order negotiations to an early conclusion, especially if proposed work involves public safety (guardrail, safety enhancement, etc.) or work related to a prolonged detour. Obviously, agreement on unit prices is desirable. However, there are times that work will have to proceed on a Force Account basis. In all cases, documented agreements on the Method of Measurement and Basis of Payment for extra work items must be obtained before the Change Order is written. NOTE: No work can begin until the contractor has either agreed to a Change Order or agreed to a basis of computing force account costs.

Change Order Approval Limits

Contracts are awarded for a specific dollar amount. Overruns or change orders expend additional funds and can only be authorized by specific people.

FHWA/Certification Acceptance

FHWA projects that have full oversight have "FHWA" stamped in red on the front page of the proposal. The Contracts Section makes the determination and affixes the red stamp.

On FHWA oversight projects, current rules require that expenditures in excess of \$50,000 be discussed with the FHWA.

The following table shows the Department's approval limits:

APPROVAL LIMITS	
Deputy Director	Over \$150,000.00
Construction Engineer	\$50,000.00 to \$150,000.00
District Engineer & DCE	\$0 to \$50,000.00

Preparation of Change Order

The following instructions are applicable in the preparation of a Change Order-Supplemental Agreement:

- Create a brief description of the work not in the contract.
- Conduct an Environmental Review and evaluation of the Environmental Commitments. Follow the guidance in the Construction Directive located in OnBase.
- Show reasons for the change; or, if the document is a combination change order-supplemental agreement, show purpose of the agreement. When the work to be performed is not covered in the specifications, the name of the items shall be worded to define the work to be performed. References should be made to similar items in the specifications or plans and the method of measurement and basis of payment definitely established.

- Show the basis of the unit prices established, such as comparison with unit prices for similar contract items or the previous year's average contract unit prices.
- Include statement as to the determination of a change in the contract time allowance.
- Show the name of the FHWA engineer and date of discussion with him/her when the Change Order is for more than \$50,000.00 and the federal-aid contract is for more than \$1,000,000 and on the Interstate.
- Enter estimated increased and decreased changes in quantities of items of work. Use standard item numbers and standard specification/contract wording, when applicable, for the new item description you define.

All Change Orders (CO) and Change Order-Supplemental Agreements (CO/SA) shall address the subject of additional working days or calendar days, if any, to be added to the contract time allowance.

The original working day or calendar day allowance is calculated by assigning some average rates of progress to the various items of work and then making some assumptions as to which items might tend to overlap during the actual performance of the work. The system is not perfect; but, regardless of the result, it does provide all bidders with a time frame upon which they can estimate a schedule for completion of the work and prepare a bid.

The performance of extra work should not be cause to suspend the working day or calendar day count. Working days or calendar days should be assessed for all extra and originally contracted work according to the guidelines for doing so, and then any relief to which the contractor might be entitled should be granted by issuing a time extension document or addressing the time in a CO or CO/SA.

In SiteManager under Reference Tables/Standard Definitions there several option clauses to be added to the Change Order. Four of the options pertain to working/calendar days.

They are further described below:

1. No additional working days or calendar days to the contract time allowance are being granted. Additional working day or calendar day consideration is not applicable to this change.
2. “_____” additional working days or calendar days to the contract time allowance are being granted.
3. Additional working days or calendar days to the contract time allowance shall be granted on the basis of the actual working days or calendar days charged for performing the work under this agreement, provided that said work is judged to be the controlling operation.
4. Additional working days or calendar days to the contract time allowance, if any, shall be granted on the monetary value in accordance with Paragraph 10. of Subsection 108.02 of the Standard Specifications.

The writer of the CO or CO/SA must use some judgment when determining which note is appropriate. In fact, there may be instances when it will be necessary to write more than one CO/SA because the items to be added to the contract do not all subject themselves

to the same rule. A little extra work, perhaps; but the right thing to do. The discussion that follows should be helpful in determining which note to select.

Note 1 - No additional days

No additional working days or calendar days to the contract time allowance are being granted. Additional working day or calendar day consideration is not applicable to this change.

This note could be used on any CO/SA which addresses subjects which are not financial in nature. An example would be an early starting date coupled with the conditional addition of the winter work special provision to the contract. A condition might be that the contractor not make any claims for delays due to utilities not being out of the way --- thus the need for a supplemental agreement requiring the contractor's signature. The work remains the same, however; and no change would be made in the contract time allowance.

This note should also be used on any CO/SA that increases the value of the contract but does not necessarily require additional time to perform the work. An example might be the substitution of one type of asphaltic concrete for another. The concrete actually used might be more expensive; but the time to mix, haul, lay, and roll it remains the same. (This does not, however, preclude the granting of some additional time due to an overrun of the final quantities.)

In general, this note could also be used on a CO/SA that has a negative financial impact on the project. An example might be the substitution of an 18" culvert pipe for a 24" pipe. The cost of the pipe and excavation is probably going to result in a savings to the project, but it is not the Department's policy to reduce the contract time allowance.

Note 2 - Specified number of days

"_____" additional working days or calendar days to the contract time allowance are being granted.

This note is the preferred note in many cases and should be utilized whenever possible. The Construction Division will rarely question the number of days granted, no calculations are required by the Final Reviewers, and the fact that the CO/SA is signed by the contractor leaves little opportunity for it to be contested. Obviously, the use of this note is restricted to situations where the supplemental agreement is created after the work is performed and the number of days required is known.

This note can appropriately be used in cases where the extra work is determined to be the controlling operation when it was performed. It definitely should be used when the time required to perform the work is grossly disproportionate to its monetary value. As an extreme example, it may take just one day to add a million-dollar traffic controller on a fifty-thousand-dollar project. Determination of an additional time allowance on the basis of cost would obviously not be correct.

This note can also be used on a CO/SA that is more administrative in nature. As an example, the contractor and the Department may negotiate some changes to the contract for which a time adjustment is a condition of the agreement. This note is a proper method to document the adjustment to the contract time allowance. It functions in the same way as would a Time Extension Document.

Note 3 - Unspecified number of days (controlling operation)

Additional working days or calendar days to the contract time allowance shall be granted on the basis of the actual working days or calendar days charged for performing the work under this agreement, provided that said work is judged to be the controlling operation.

This note should be used in situations similar to those described for Note 2 when the CO/SA is completed prior to the work being performed. When it can be anticipated that the additional work will be the controlling operation or the value of the work is disproportionate to the time required to perform it (especially when the work takes a long time to complete but is not very expensive), this note should be used. In some cases, it may be appropriate to grant some additional time on the basis of monetary value for extra work performed when the work is not the controlling operation for the entire time required to complete it.

The Project Manager should closely monitor the work when choosing this method of calculating an increase to the contract time allowance. The completion of other work is certainly not discouraged or prohibited, but the contractor should not be allowed to intentionally slow the progress of the extra work to gain the advantage of allowing other contract work to be completed concurrently during the time period being added.

Note 4 - Unspecified number of days (monetary value)

Additional working days or calendar days to the contract time allowance, if any, shall be granted on the monetary value in accordance with Paragraph 10. of Subsection 108.02 of the Standard Specifications.

This note serves to cover those situations not addressed by Notes 1, 2, or 3. It is an inexact method, but is usually a fair way to provide additional time to the contract time allowance when the methods associated with Notes 1, 2, and 3 are clearly not more appropriate.

It should be used to address those additional items of work which are similar in nature to other items of work in the contract but for which it is difficult to determine or monitor the actual amount of time required to complete. An example might be additional work performed sporadically over a long period of time or the addition of more work of a type already in the contract --- such as may be added by a plan revision.

The use of this note does require the Finals Reviewers to calculate the amount of extra time to be granted. The calculation should be done on the basis of the monetary value alone, and no consideration should be given to whether or not working days or calendar days were charged during the performance of the work. If the extra work to be added by the CO/SA could have been anticipated prior to the letting, time certainly would have been allowed for it; and it is only fair that an additional time allowance be considered after the fact.

The Project Manager should have the best feel for the type of working day or calendar day consideration that is most appropriate. He/she is encouraged to make a fair evaluation of the situation and select the method that fits. As indicated in the discussion above, the use of Note 2 is encouraged.

Cost Overrun/Underrun Notification (NDOT Form 74)

When project costs overrun or underrun by \$50,000 or more and the change in cost is not reflected in a "Change Order/Supplemental Agreement", the Project Manager shall prepare and send a "Cost Overrun/Underrun Notification" (NDOT Form 74) to Laurie

Burling laurie.burling@nebraska.gov as an attachment via email. Laurie will print the form and circulate it for the appropriate approval signatures.

NDOT Form 74 is available in the folder titled DOTForms [dotfs\public\DOTForms](#). Space is provided in the identification block in the lower-left corner to provide a unique identification before saving the file. The Project Manager's name must be shown in the "Prepared by" window, but an actual signature is not required to submit to the NDOT Form 74 to the Controller Division.

Please note that the net change in the total project cost --- not an individual group --- shall be the determining factor when deciding if an event should trigger the preparation of NDOT Form 74. Caution is necessary as it is not always apparent when the costs have overrun by more than \$50,000. However, as soon as an overrun/underrun of \$50,000 is noticed, then a NDOT Form 74 must be initiated by the Project Manager.

Work Orders

(SSHC Subsection 109.05) - If there is sufficient time to execute a change order-supplemental agreement or force account agreement prior to beginning the extra work, no work order need be issued. The change order-supplemental agreement or force account agreement shall provide the basis for authorization and payment for extra work. The work order shall state that the work will be done either by change order-supplemental agreement or by force account agreement.

If prices can be agreed upon at the time of writing the work order (see *SSHC Subsection 109.05*, Paragraphs 8 and 9 regarding rental rates), but insufficient time exists to permit execution of a change order-supplemental agreement, a work order shall be prepared authorizing such work and then be followed by a change order-supplemental agreement formalizing the prices or basis of payment stated in the work order.

If negotiated prices cannot be agreed upon at the time of writing the work order, the work will be done by force account. Under certain circumstances, when approved by the Construction Engineer, this may be changed at a later date to a change order-supplemental agreement.

The work order shall be signed by both the Project Manager and the contractor or their superintendent.

The Project Manager and District Office shall implement the following procedures to expedite payment for extra work.

1. The Project Manager shall keep a file of work orders issued on a project and shall take the necessary steps to get agreements consummated.
2. The Construction Division shall track the change orders progress.
3. Contractors must furnish back-up information to justify prices they quote for extra work. Contractors should notify the state immediately of items of work that they do not think are covered in the contract.
4. The introduction of any new item of work not included in the contract items, no matter how small the quantity, must be covered by a change order-supplemental agreement establishing a unit price for the new item.
5. Canceled items (materials furnished by the contractor and not used due to a change in plans) most often involved are pieces of culvert pipe ordered but not installed. In some cases the contractor may wish to retain the materials and no

further action need be taken when this is true. (See *SSHC Subsections 109.06* for further information.)

Force Account Agreements and Statements (*SSHC Subsection 109.05*)

Force Account Agreements - It is necessary that force account agreements be executed when the nature of the proposed work is such that the costs involved cannot be accurately estimated or when there are no similar items included in the contract which may be used as a basis in determining unit prices.

Before beginning the work or preparing the agreement, the Project Manager should have a definite understanding with the contractor's representative regarding the labor, equipment, and materials to be used and the manner in which the work is to be prosecuted, and the rates to be paid for the equipment. If a satisfactory understanding cannot be reached, the matter should be referred to the District Engineer.

In preparing the agreement, the Project Manager should be very careful to include rates for all labor and equipment that may be used in the work. If it becomes necessary to use labor or equipment for which rates are not established in the agreement, the Project Manager normally shall negotiate the rental rates and shall immediately prepare and submit for approval a force account agreement supplementing the original agreement and establishing the rates to be paid for such labor and equipment. However, it will not usually be necessary to issue supplemental force account agreements for additional labor rates if the original agreement covers a rate range from the minimum required by the detailed schedule listed in the contract Special Provisions to the rate the contractor is paying or which he/she anticipates he/she will pay due to future rate increases.

Equipment rental rates are negotiated or determined as indicated in *Construction Manual Section 104.07*. The approved rental rates shall only apply to equipment used under the following conditions:

The contractor's equipment that is available on the project. If equipment not available on the project is needed only for the extra work, it may be necessary to pay rates in excess of the approved rates or to pay compensation for the cost of moving in the equipment. (Mobilization is explained in *Construction Manual Section 104.07*.)

If it is necessary for the contractor to rent equipment for the extra work from a third party, the rate established shall be the actual rental cost plus fifteen percent for overhead and profit.

Equipment used on extra or additional work performed under normal working conditions on a force account or contingent item basis.

If the equipment is to be used under working conditions involving abnormal expenditures for maintenance, fuel, or service, it may be necessary to pay rates in excess of the approved rates.

If major quantities or extended amounts of work are involved, it may be equitable and necessary to negotiate rates at less than those indicated above.

The approved rates shall be paid only for the time actually used in the performance of the work ordered by the Project Manager. Standby time, time involved moving to and from the work and repairing and greasing time shall not normally be included for payment.

If the contractor is required to hold equipment which he/she has brought in specifically for the extra or additional work "on standby" because of circumstances beyond their control, consideration may be given to payment for normal schedule "standby time". In such cases, it will be necessary to negotiate lower hourly rates with the contractor which will not include compensation for fuel, oil, grease, repairs and other costs which would not be incurred on the equipment "standing by".

The Project Manager should be careful to obtain the correct name, model size, series number, and type of the equipment and major attachments - (loader or dragline bucket, etc.) involved for each item of equipment for which a rental rate is to be established. This information should be furnished to the District Office and they may then determine the approved rate from the "Rental Rate Blue Book". Complete information is needed to determine the proper rate since the rates vary considerably depending on the model, series, etc. The name of the established item should be descriptive but brief, for example, "Crawler Tractor Loader, 1 Cu. Yd." The body of the force account or supplemental agreement should then include all of the information necessary to determine and verify the correct rate, for example "Caterpillar, Model 955 'H', 100 horsepower, 1 Cu. Yd."

If fully operated rates, including operators' wages are to be established, the rate paid the operator shall be increased by 50 percent to cover insurance, social security taxes and profit and added to the approved rental rate, rounding to the nearest five cents. When such rates are established, the words "fully operated" shall be included in the equipment rental item.

The Project Manager should call or write to the general office of the contractor advising him/her of the nature of the proposed work to be performed on a force account basis and request that they advise by letter regarding their insurance premium rates for workmen's compensation, public liability, and property damage. Request that the contractor send copies of their letter to the District and Construction Engineers. The letter stating the insurance rates should be attached to the force account agreement to be filed as a part of the permanent records. The agreement may also be prepared without the insurance rates and sent to the contractor's office for signature with instructions that the contractor place the rates on the agreement.

The reverse side of the agreement form must contain the "Estimate of Cost". This itemized estimate of the cost of the work shall include an item for each class of labor or piece of equipment for which a rate is established in the agreement. The estimated number of hours that it is contemplated that each item of labor and equipment will be employed shall be shown, extended at the established rates, and totaled. Allowances for insurance, social security taxes, and profit shall be shown and included in the total cost. In the event that the contractor will be required to furnish materials in performing the work, the quantity and estimated cost of each item of material should be shown and included in the totals.

The hourly labor rates to be used in the itemized estimate shall be the average rates that would be earned, including overtime, if the laborer worked a full week. Such rates shall be referenced with asterisks to the following note to be entered below the estimate:

"Average rates earned at the established basic rates in a 40 hour week."

The heading of the "Estimate of Cost" on the reverse side should be on the same end of the sheet as the signatures on the face of the form so that it will not be obscured when it is placed in the Lincoln Office file.

Force Account Statements - A force account statement, signed by both the Project Manager and the contractor's representative, is required for each calendar week during which work is performed. These reports should be prepared and signed weekly. In the event that overtime payment is involved and the agreement requires that reimbursement be made at the average hourly rate earned during the week, the statement shall be prepared and signed on the Monday following the week in which the work is performed.

A daily record of labor, equipment and materials used on force account work shall be kept in SiteManager. Work on force account and contract items will often occur at the same place at the same time. It will be the duty of the Project Manager or inspector to record their estimate of the force account labor and equipment hours and check with the contractor's foreman each day.

A receipted invoice is required for all items of expense incurred by the contractor except insurance, social security taxes, and the items for which rates are established in the force account agreement. The quantity or amount of such services furnished or materials used during each week may be included in the statement for that week, or the total quantity or amount for all materials or other expense covered by the same agreement may be included for payment on a later statement, substantiated by receipted invoice. Payment cannot be made for such items until the receipted invoices are received.

The contractor shall furnish the Project Manager with a copy of their weekly labor payroll which contains the names of those personnel working on force account items. The hours worked and the rates paid to labor on force account work shall be compared with this transcript. Any discrepancies should be investigated and corrected to insure the accuracy of the force account statements.

Alterations of Plans or Character of Work (*SSHC Subsection 104.02*)

This subsection in the specifications authorizes the Department (Project Manager) to increase or decrease quantities of contract items for which there are unit prices included in the contract, if changes in plans or alterations of construction make such increases or decreases necessary or desirable.

A CO/SA may be necessary when there is a significant change in the character of the work. A "significant change" is defined in Subsection 104.02. A CO/SA will not be required if the Project Manager and contractor agree that the additional work can be done at the bid price. Such agreement, preferably including the contractor's initials or signature, should be documented in SiteManager and in the Project Manager's diary.

Sign Deductions

The change order for sign deductions must indicate that "State Funds Only" shall be used.

104.09 VALUE ENGINEERING (*SSHC Subsection 104.03*)

In accordance with *SSHC Subsection 104.03* a contractor may submit a value engineering proposal to the Project Manager with copies to the District and Construction Division. The purpose of value engineering is to encourage alternative, cost effective measures which produce equal or better quality end products.

Value Engineering proposals will not be accepted for:

- Changes in basic design of a bridge or pavement type. For example: Value engineering a project from PCC to ACC will not be acceptable. Changing a designed bridge to a box culvert is not acceptable.
- Changes which the contracting authority may already be considering.
- Basing a value engineering proposal on, or similar to, existing standard Specifications, Special Provisions, or design plans and standards adopted by the contracting authority. For example: A plan was let using 15 foot (4.6 m) PCC joint spacing. A value engineering proposal would not be accepted changing this to 20 feet (6 m) because Roadway Design Division standards have included this spacing as an acceptable standard.

The written proposal shall have sufficient detail to be evaluated for compliance with the requirements. The detail provided must also allow for reviewing how a proposal impacts the entire project. It shall include:

- A description of existing requirements and proposed changes
- All affected contract items, including new, extra work items and supporting justification for that extra work
- Unit prices requested for the work
- Effects on crew, equipment, and production needs for the project
- Impact on the construction period
- Schedule for obtaining all required materials

It is very important to pursue these requests quickly to maximize potential savings. Once a proposal is received, the Project Manager should (a) discuss the merits of the VE proposal with the District Engineer, and (b) initiate an office review and forward review comments to the Construction Division within a week. The Construction Division will coordinate the review with other offices, including selected section leaders (Design or Bridge) and the FHWA, if appropriate. Following this review, the Construction Division will notify the District and Project Manager of approval or disapproval and any special considerations or requirements. Following notification from the Construction Division, the Project Manager will prepare a written notification to the contractor outlining the review and conclusions of that review. If a proposal is acceptable, this notification will form the basis for issuing a Change Order and Supplemental Agreement to implement conditions of the value engineering proposal. Therefore, a notification should include:

- A restatement of any changes
- All costs involved, and how costs will be addressed
- Any Specification requirements which result from changes or modifications to the existing contract
- Details pertaining to special requirements for materials inspection and testing, if applicable
- Any other special considerations or conditions

If a proposal is not approved, the notification needs to include reasons for rejection.

The Construction Division has established a goal of ten days to complete the entire review and notification process.

104.10 PLANT INSPECTION

Portland Cement Concrete Paving Plant (SSHC Subsection 1002.02)

The National Ready Mixed Concrete Association Quality Control Manual, Section 3, *Certification of Ready Mixed Concrete Production Facilities* lists the minimum monitoring requirements. A plant inspector (Construction Technician) will normally be assigned to each project with duties split between plant and grade inspection. Plant inspectors should schedule work so the plant can be visited daily during production. The amount of time spent at the plant will depend on the overall quality control at the production plant.

Structural Concrete Plant

Ready mix tickets shall be prepared and signed by the person batching the concrete or the plant inspector.

Asphaltic Concrete Paving Plant Inspection (SSHC Sections 503, and 1028)

A plant monitor will normally be assigned to each project with duties split between plant and grade inspection. The plant monitor should schedule work so that the plant can be visited daily during production. The amount of time spent at the plant will depend on the overall quality control at the production plant. The contractor's QC inspector will be providing production and placement information to be entered on the daily plant report. Visits of the plant monitor to the plant laboratory for exchange of information and book work will normally be done daily.

The plant monitor will be responsible for witnessing core sampling and performing verification density tests.

Testing Equipment and Supplies

Necessary plant inspection forms will be furnished to the producer at no cost. The producer can request these through the Materials & Tests Engineer or Project Manager. It is a good idea for the plant monitor to carry a supply of forms and make these available to the producers as needed.

NDOT plant monitors can utilize contractor furnished equipment for testing required at the plant site.

Samples

The contractor's inspector and NDOT plant inspectors should indicate on the sample submittal form the field lab telephone number and hours they can be contacted for test results.

For QA/QC projects, the contractor is responsible for field sampling. The project monitors should witness sampling to the extent that they are assured the samples are taken properly. Additional witnessing of obtaining, identifying, splitting, testing, and storing samples will be as directed by the QA/QC Specification.

104.11 PLANT REPORTS

The Project Manager should make arrangements with the contractor's plant inspector for timely receipt of plant reports. The original and all copies of the plant report shall be kept at the plant until all documentation is completed. Normally, this will be the day following the end of the reporting period. Review and distribution of the reports will be made by the Project Manager. This distribution will include a copy to be returned to the contractor's plant inspector. Prompt consultation between the plant inspector and the NDOT plant monitor shall follow any significant error or omission.

Documentation

A separate field book entry in SiteManager should be set up on each project to document plant inspection. Some flexibility in the suggested format may be necessary depending on project size, type of plant, and if the QA/QC Specification applies. It is important to document discrepancies and corrective action taken by the contractor.

104.20 FIELD TESTS

104.21 FIELD TESTING ON CONSTRUCTION PROJECTS

Materials

All sampling, measuring, and testing for construction project quality control shall be performed as prescribed in the [NDOT Materials Sampling Guide](#) and the [NDOT Standard Method of Tests](#).

Project Acceptance Sampling and Testing

Both construction inspection personnel and the contractor are responsible for the field sampling and testing portion of project acceptance tests. The Project Manager must review inspector assignments and maintain a program of continuing training for personnel and training of additional employees if required. Samples taken by inspectors and submitted to District or Central materials laboratories must be properly and completely identified on "Sample Identification Form" (NDOT Form 12) or other appropriate forms as required.

The *Materials Sampling Guide* shows the minimum required frequency of tests for various types of work. Additional tests should be made as necessary for adequate project control. Reports showing test results must include all tests made.

Reports do not need to be included in field books or diaries.

Assurance Sampling and Testing

SSHC Section 1028 discusses the requirements related to asphalt assurance sampling and testing, most of which are Materials & Research Office responsibilities. Occasionally, assurance samples have not been taken on some projects because timely notification of ongoing work was not made. This has been more common with test cylinders from bridge deck pours and culvert projects.

While the actual taking of assurance samples remains the responsibility of Materials & Research personnel, it is of equal importance that project inspectors provide timely notification regarding available dates for testing.

104.30 TRUCKS/HAULING OF MATERIALS

The Motor Carrier Permit Office is responsible for the monitoring and enforcement of truck weights on roadways outside the project limits and on roadways within the project limits utilized to maintain through traffic. Our involvement in monitoring hauling units in these situations should normally be limited to notification of the appropriate Motor Carrier Permit personnel if obviously overloaded trucks are suspected. The primary focus of our attention should be insuring compliance with legal axle loads on pavements and structures on roadways within the project limits that are closed to the traveling public.

104.40 SCALES

Aggregates are generally measured in the delivery vehicle on a platform scale. Asphaltic mixtures may be measured over platform scales, in silos on load cells, in hoppers, or by counting batches.

104.41 SCALE TICKETS

The contractor shall provide a scale ticket for each load showing the required mass information on the procedure being used, the project number or contract description, the truck number, the date, and the type of material.

The required data to be automatically printed on the scale tickets will vary according to the method of measurement (hopper, silos on load cells, batch scales, or platform scales) and type of system (automatic or semi-automatic).

Automatic or Semi-Automatic Measuring

- For hoppers, batch scales, or silos on load cells, all tickets printed automatically shall include the gross mass, empty mass of the hopper or mass not discharged, net mass of material for each drop, and the total net mass for the load. When measured under the semi-automatic procedure, the scalemaster may include on the ticket the calculated total net mass.
- For batch scales, the batch mass and batch count are to be automatically printed under both procedures. The total net mass may be printed with a system or calculated by a scalemaster with a semi-automatic system.
- For truck platform scales, all scale tickets printed automatically shall include gross mass, tare mass of the truck, and net mass of the load. For semi-automatic measuring, the printer shall print the gross mass, and the scalemaster shall conduct all measurements and may enter by hand or by printer the tare mass of the truck and calculate the true net mass.

Manual Measurement

- For manual measurement of loaded trucks (project quantities less than 10,000 Mg) (11,000 ton), scale equipment on truck platform scales may or may not include a mechanical ticket printer. A scalemaster shall include the gross and tare mass and calculate the net mass on the scale ticket. The Project Manager may arrange for the measurement to be witnessed.

The inspector will collect the accompanying load ticket for each load of material on its arrival at the work site and check to see that the ticket has been validated by the scale inspector when such scale inspection is required. The inspector will observe each load of delivered material to detect any obvious deficiencies in quality or in quantity and reject any loads which are unsatisfactory.

The inspector will sign or initial the scale ticket for each accepted load to verify the material was delivered and accumulate the tickets on a daily basis for determination of pay quantities. Quantities for each day's operation shall be totaled and checked against the contract records and any discrepancy promptly resolved.

The requirement that an inspector personally receive all load tickets at the time of delivery may be relaxed only in cases of very small quantities or intermittent deliveries under conditions where the Project Manager or inspector can visually determine the approximate quantity delivered.

On asphalt projects, it is permissible for a contractor's employee to collect the tickets and place them on a clipboard. An inspector must be present at the laydown operations at all times and observe the collection of the tickets.

104.42 TRUCK PLATFORM SCALE APPROVAL

The *SSHC Subsection 503.03* explains requirements for scales. A platform scale used for measurement of items such as crushed stone, base and subbase material, and asphaltic mixtures, contracted for and measured by the Megagram, shall meet these criteria.

Truck Platform Scale Use

Each truck to be measured shall be tared twice a day. Taring of trucks should be on a random basis during the day's operation, using the previous day's tare mass until a new tare mass for that day is determined. No truck may be used for hauling material paid for on a mass basis until tared.

104.50 SMOOTHNESS

104.51 TESTING

SSHC Sections 502 and 602 contain the current asphalt and concrete pavement smoothness Specifications.

The special provisions provide the current smoothness Specification for bridge decks and bridge deck overlays. They discuss the requirements of smoothness criteria for bridge decks, new approaches, bridge deck overlays, and overlaid approaches. They will also indicate when evaluation is excluded.

Any pavement and bridge deck areas carrying traffic, but excluded from profilograph testing, must be checked with the 3 m (10 foot) straightedge or "bump buggy". Deviations in these areas shall not exceed 3 mm (1/8") in 3 m (10 feet).

If two or more lanes are placed in a single pass with a full width paver, smoothness results of adjoining lanes should be evaluated separately and independently so that each lane has its own profilograph trace.

104.52 EVALUATION

Bridge Approach Smoothness

The final 1.8 m (6 feet) at a section end may be excluded from testing and evaluation only when the contractor is not responsible for the adjacent section, but the entire header-to-header section should be included in computations for price reduction or incentive assessments.

The 1.8 m (6 feet) on either side of a 100 mm (4") expansion joint may be excluded from testing by the Project Manager, since the small averaging wheels on the profilograph

may fall into the joint and possibly damage the profilograph and affect the trace. Contractors should fill these joints or cover them to allow the profilograph to run through the joint area.

A composite header, where one side is ACC and one side is PCC, is excluded from profilograph testing only when this header is at the extreme end of the project (i.e., only where one half of the header joint is existing pavement). If the composite header is constructed as a single project, no exclusions for smoothness testing should occur since both types of pavement (ACC and PCC) are under the same contract. The smoothness index should be determined independently for each surface type, but the bump specification should apply across the header.

Bridge Deck Smoothness

Profilograph tests will be conducted in each traffic lane approximately 1.0 m (3 feet) from the outside lane line of each traffic lane segment of bridge decks and bridge deck overlays.

The final 1.8 m (6 feet) at the end of a bridge and at an expansion joint are not included in testing or evaluation, but should be included in computations for incentive or price adjustment assessments. These areas will be evaluated for deviations exceeding 3 mm (1/8") in 3 m (10 feet).

Profilograph tests for bridge approach sections or overlay of bridge approach sections are run 1.0 m (3 feet) from the outside lane line of each traffic lane. These areas shall be corrected for smoothness and will not be used in the computation for incentive or price reduction of bridge decks or bridge deck overlays.

104.53 BUMP CORRECTION

Exact location of 10 mm (3/8") bumps requiring correction has proven difficult particularly on resurfacing projects. Referencing by station location, string line, and rolling straightedge often lacks the precision necessary for identification of exact bump locations. Locate bumps on the pavement surface during initial profilograph testing with spray paint or have a profilograph available during correction to locate bumps and monitor correction results.

104.60 LIQUIDATED DAMAGES & EXTENSION OF CONTRACT TIME

Liquidated Damages (*SSHC Subsection 108.08*)

The Construction Division will assess liquidated damages based on the District's recommendation.

The Construction Division will be responsible for settling liquidated damage disputes.

If project level good faith efforts fail to resolve differences, the Project Manager shall request negotiation assistance from the District Construction Engineer. In addition, factual information relative to the issue(s) shall be forwarded to the Construction Engineer.

Should combined efforts described above fail to resolve dispute(s), the issue will be considered to have reached an impasse. At this point, a meeting with all affected parties shall be scheduled with representatives from the Construction Division.

Contract Time Extensions (*SSHC Subsection 108.02*)

In SiteManager, all time extensions are change orders. The value of a time extension is the liquidated damage amount times the number of days extended. The "Approved Limits" chart in Subsection 104.08 applies to time extension change orders.

A good example would be when a contractor was held up due to a delay in delivery of material and it was necessary to charge working days until the contractor provided proper documentation. After proper documentation, the contract time allowance is extended by the District for the amount of working days assessed during the delay.

It is intended to use this means to correct mischarged days rather than going back and revising the working day report. An example of this would be when a contractor contests the working day charges shown on the working day report and he/she is considered to be correct.

The "Head to Head", "Detour" and "Earth Shouldering" time allowances are specific time allowances within the time frame of the overall contract allowance. They usually are not, but can be, affected by contract time extensions.

SSHC Subsection 108.02, Paragraph 6 says the Project Manager will grant an extension in the working day time allowance consistent with delays resulting from conditions beyond the contractor's control.

The Project Manager should be careful to keep complete and accurate records and information on any conditions or circumstances which delay the work. The Project Manager should keep good records, particularly on circumstances in connection with acts by the State and delays (to the work) caused by other contractors. If such delays are involved and the time allowance is exceeded, the contractor will surely request and be entitled to an extension in the time allowance. In the fair handling of such requests, the Construction Division review relies principally on the records kept by the Project Manager, and accurate, complete records on any such delays are of prime importance.

If the working day time allowance has been exceeded, the Project Manager should prepare a resume of the working days charged to accompany the final records. The resume should be based on a review of the working days charged, considering any requests for extensions in time made by the contractor.

104.70 ACCIDENTS

Whenever a collision occurs in a construction zone, the Attorney General suggests that the Project Manager immediately video, photograph, or document the area to verify the position of signage, obstructions, traffic control devices, and other pertinent features.

Use the publication *Collecting of Accident Data* as an aid when reporting accidents.

105.00 MEASUREMENT AND PAYMENT

105.01 GENERAL

The Project Manager may elect to pay the plan quantity for items like pavement when the item is built to plan geometrics. Measurements are not always required when the item is constructed to plan and specification requirements.

If the item of work does not conform to the specification requirements, a new item of work must be added as extra work. Example: On guard rail, if it is necessary to leave out a post because of a drainage structure and use a double safety beam section, this

section of guard rail must be paid for as extra work as it does not conform to the specification requirements for guard rail.

105.02 MEASUREMENT OF QUANTITIES AND COMPENSATION FOR ALTERED QUANTITIES

All standard items of work listed in the contract are to be measured for payment using English (metric) System of measurement. A list of standard contract items and their units of measurement is available at each field headquarters and the NDOT Web Page. Inspectors or survey parties concerned with measuring or recording contract items will need to be informed of proper procedures to be followed.

The contractor may request that materials hauled to the project and paid for by the cubic meter (cubic yard) be measured and a mass conversion factor be used for determining the cubic meters (cubic yards) of material delivered. When the Project Manager approves this procedure, the mass of the material must be obtained on approved scales, the material must be hauled approximately the average haul to the point of delivery, and then the volume of the material must be determined. The mass of the material in kilograms (tons) divided by the volume of the material in cubic meters (cubic yards) will be the mass conversion factor. The cubic meters (cubic yards) of material used may be determined by dividing the total mass delivered by the mass conversion factor.

The Project Manager will determine the frequency for establishing mass conversion factors. The frequency will be dependent on the quantity of material delivered, on variations in the material's characteristics (moisture content, gradation, etc.), and on variations in the length of haul.

The final record for the contracted work must include all records and computations used in determining the mass conversion factors.

If provision is made that payment of any contract item is to be made as an "established quantity", payment will be made on the established quantity listed unless authorized alterations are made. Established quantities are often listed with prescribed tolerances set forth to allow for minor construction changes without requiring that final measurement be made. Authorized alterations are considered to be substantial changes in construction items which would usually be authorized by revised plans or specifications, and may be listed in two categories. (See *SSHC Subsections 104.02, 109.01 and 109.04.*)

- The first type would be an alteration of a minor item and does not involve supplemental agreements. In this case, payment will be made at the contract unit price for the actual total.
- The second type is an alteration of a major item involving an increase or decrease of more than 25 percent of the item. This situation may involve a supplemental agreement stipulating changes in the actual quantities of the work and establishing (if necessary) a new price per unit price for such work. If there is an overrun, the original contract quantity plus 25% is paid for at the bid price. The extra quantity above 125% is paid for at the new negotiated cost. If there is an underrun, the entire quantity is paid for at the new negotiated price per unit. Payment would then be made at the new unit price for the increased orders and quantity.

105.03 CANCELLED ITEMS (MATERIALS FURNISHED BY CONTRACTOR AND NOT USED DUE TO CHANGES IN PLANS)

The Department will, if the contractor desires, take over unused material at the cost delivered to the location at which it is accepted by the Department.

It will be necessary for the District Engineer or the Project Manager to initiate a change order providing for payment for such materials. The item included in this agreement shall include the phrase, "delivered but not incorporated in the work", in order to specifically identify such materials. The unit price established for items of material furnished by the contractor and not used because of a change in plans will usually be based on the actual cost of the materials, plus 10 percent to cover overhead, handling, other costs and profit. To substantiate the unit price established, the Project Manager should obtain a copy of the receipted invoice for the material and attach it to the supplemental agreement.

Change Order/Supplemental Agreement must be created to pay this. It will also be necessary for the Project Manager to include an explanation of the transaction in the Change Order/Supplemental Agreement. Complete information regarding the disposal made of the material, such as the supply base to which it is delivered or the project on which it is used, is essential.

Payment for such materials must be included in the final estimate as a nonparticipating contingency.

105.04 PARTIAL PAYMENT

The contractor is to be paid once a month for satisfactory progress on the basis of work completed during that month. The Project Manager prepares a contractor's estimate in the computer stating the estimated quantities for items of completed work to date. This document is forwarded to Lincoln through the District Engineer's office for processing and payment via E-mail.

When the value of the work completed during the first half of the contractor's pay month exceeds the amount stipulated in the specifications (usually \$10,000.00), a semi-monthly contractor's estimate is prepared. All partial payments are made on satisfactory work and materials only, as evidenced by complete certifications or test results as required. Defective work or material shall not be included for payment until the defect has been remedied.

105.05 FIELD MEASUREMENT AND PAYMENT

Photographs and Video - Documentation on film can save many questions and provide critical answers. Take a picture any time it may be helpful.

Field Records - General - Payment for most contract items is based on the plan quantities. Final measurements should be avoided as long as the specifications permit and the contractor does not dispute the quantities. Their construction should, however, be documented as described under "Inspection Notebooks" with the statement (if applicable) "Constructed as per plans" and substantiating data or measurements, if necessary, also entered in the record.

Field records must be properly kept to substantiate that the contractor has conformed to the requirements of the plans, specifications, and Special Provisions both as to quantity, usually involving measurements, and quality, usually involving tests, of the work or material items used on the project.

Field SiteManager Entries or SiteManager Item Documentation - Field measurements made for pay items of work and records of placement of materials shall be entered directly in SiteManager.

Field and lab test results on quality of materials will be entered into SiteManager. Record and document tests using approved Material Sampling Guide and SiteManager procedures.

The item documentation records should indicate the stationing used, date placed or constructed, and sketches with dimensions if necessary to give clear understanding of the placement and material used. The names of the party or engineer making the measurements and dates performed must be entered in SiteManager or included with the supporting documentation. Materials used in the construction of the project for which no direct payment is made but are considered subsidiary to other pay items should also be documented in SiteManager, Materials Management Section.

SiteManager should contain a detailed summary of all shipments received for the project, including the kind of material, the identification number, net mass, date received, delivery point and, if possible, the point of origin. Include distribution to the proper group of the contract and information on material received but not used on the project.

The laydown inspector shall enter in SiteManager the activities required in the performance of their job. This would normally include such items as types of equipment being used, equipment checks, tonnage checks, thickness checks, temperature checks of mixture, etc. **All entries are to be dated.** Also, we would like to bring to your attention that the inspectors are to sign the scale ticket on receipt and acceptance of the material. Base all entries on facts, not opinions.

Final computations shall be entered directly into SiteManager or other approved recording and documentation methods used in conjunction with SiteManager. Operations of performing computations and checking computations shall be identified on each page of computations by operation, date, and the name or initials of the individual.

Plans, tables, and sketches provide supplementary details necessary to clarify SiteManager entries for pay items. Any such plan or sketch shall be saved electronically in the project files. Supplementary plans and sketches are sometimes necessary to define the extent of a pay item sufficiently enough to remove any doubt as to its limits.

- A good technique is to build the sketch or table in the computer and then save it electronically.

Supplementary sketches are sometimes necessary to show measurements of irregular areas for both pavement removal and the construction of new pavement.

Computation spreadsheets should be used where detailed computations are necessary to determine pay quantities. These computations are made from SiteManager, cross section, or sketch information and should be fully referenced in SiteManager. It is necessary that all computations be referenced in SiteManager or saved electronically in a project folder (Read Only Access) so that the computations can be checked for correctness of method and accuracy.

Scale Tickets - Scale tickets are used to substantiate quantities of materials which are paid for by mass. The original copies (white) should be submitted with the final records of the project to the District Final Reviewer. Preparation of scale tickets and distribution is discussed in the section pertaining to asphaltic concrete.

105.06 CONTRACTOR'S ESTIMATES

SSHC Subsection 109.07 allows payments to the contractor if satisfactory progress is being made. These contractor's estimates will include quantities and amounts for items of work completed to the date of the estimate.

Progress estimates are completed in SiteManager by the Project Manager and signed electronically. It is the District Engineer's responsibility to review and approve the estimate in a timely manner, sign it electronically, and forward it electronically to the Controller.

Upon receipt by the Controller, the estimate is processed further by the Construction and Controller Divisions before it is released for payment.

On all Federal-Aid projects, it is necessary to separate participating and nonparticipating items of work on the progress estimate form by dividing them into separate summaries for each project in a contract. Each line is properly divided by the Controller Division when the item is loaded in SiteManager. This procedure is done to comply with our agreement with the Federal Highway Administration regarding procedures for current billing and current audits. Items which are added to the contract should be included in the proper group in the participating or nonparticipating summary as applicable. Items added by change order-supplemental agreement should be considered as participating unless the agreement form is marked "nonparticipating" when returned from the Lincoln Office. The District Office should be consulted for further information on any item for which there is some uncertainty regarding its status.

For contracts which include wage rates, progress estimates shall not be released by the Project Manager until the contractor and subcontractor have submitted all delinquent payrolls and Forms WH-348. These reports shall be considered delinquent when they are not in the Project Manager's hands by the seventh day after the date on which the employees are paid. Notify the contractor by letter, with a copy to the Construction Division, of any delinquent payrolls and WH-348's in advance of the estimate date. The estimate should be prepared at the regular time and forwarded immediately upon the receipt of the payrolls.

Estimate Preparation

Please remember to update Line 2 (current quantity) on the estimate for all items added by plan revision or supplemental agreement. This adjustment should be made as soon as you receive the plan revision or supplemental agreement.

The Controller Division depends on Line 2 being accurate so they can allocate sufficient funding to each project.

DISTRICT ESTIMATE SCHEDULE		
District No.	Regular Estimate Date (Only if money due contractor)	Alternate Estimate Date (\$10,000 or more must be paid)
*1	1st Saturday of Month	3rd Saturday of Month
2	2nd Saturday of Month	4th Saturday of Month
*3	1st Saturday of Month	3rd Saturday of Month
4	2nd Saturday of Month	4th Saturday of Month
5	4th Saturday of Month	2nd Saturday of Month
6	3rd Saturday of Month	1st Saturday of Month
7	4th Saturday of Month	2nd Saturday of Month
8	4th Saturday of Month	2nd Saturday of Month
* Districts 1 and 3 use the 5th Saturday of the month instead of the 1st Saturday of the future month as Primary Cutoff day when there are 5 Saturdays in a month.		

Stockpiling:

SSHC Subsection 109.07, Paragraph 4. provides that estimates may also be allowed for acceptable nonperishable materials meeting the requirements of the plans and specifications and delivered in the vicinity of the project or stored in acceptable storage places. This will generally apply to aggregates, structural and reinforcing steel, metal specialty items delivered but not incorporated in the work, and other materials which cannot be used for extended periods of time because of delays beyond the contractor's control. The amount included in the estimate will be determined by the PM, but in no case shall it exceed 100-percent of the value of the materials as shown by copies of receipted invoices or costs. Partial payments shall be listed under the stockpiling category with an "800" series number.

As the material is used, the payment for this material should be reduced accordingly in the stockpile item on the estimate.

Payment for stockpiled material is "permissive", and it should not be interpreted to be a requirement in cases where the material will remain in storage a comparatively short time (less than one month). When there is a question as to the inclusion of a material for payment, the District Construction Engineer should be consulted for instructions.

SSHC Subsection 106.02 states that:

All materials are subject to and will be inspected, tested, and accepted by the Project Manager before incorporation in the work.

SSHC Subsection 1001.02 requires:

Materials which must be documented by a certificate of compliance, certified test, or test reports shall not be incorporated into the work until such certificates have been delivered to the Department and verified for compliance.

It follows from the above that material items which have not been tested and accepted, or for which appropriate certification, as defined in the Materials and Research Manual, has not been delivered to the State, should not be included on an estimate for payment. Likewise, no material item which has been stored in accordance with Paragraph 4. of Subsection 109.07 of the Specifications should be included on an estimate for payment unless the appropriate test data or certifications for compliance with the specified requirements are in the files of the Project Manager and documented in SiteManager.

The Project Manager shall maintain documentation of progress estimate quantities.

Types of Contractor Estimates – SiteManager has only three types of estimates:

- **Progress** – all estimates prior to the “Final Estimate.”
- **Final** – generated once District has completed its review and is ready to forward the project to Lincoln for “Finaling.”
- **Supplemental** – all estimates generated to change the “Final Estimate.” Additional estimates are obsolete in SiteManager. However, the PM must notify the Construction Division when a project is complete – which used to be the purpose of the additional estimate. In SiteManager, the PM must send an email note to “NDOT Const-Completion Notification.” The Finaling Manual explains what must be included in the “note.”

Processing Estimates – Each District should direct a copy of signed estimates to the Construction Division printer (CON1) as soon as possible after affixing the electronic signature.

Each District is encouraged to sign and print estimates as often as possible. The uniform and steady arrival of estimates in Lincoln is encouraged and appreciated by both the Construction Office and the Controller Division.

Contractor's Statement of Compliance (Form WH-348) - Form WH-348 shall be submitted for each weekly payroll period by each contractor and subcontractor on all projects financed by Federal Funds. (Form WH-348 is not required on other than Federal-Aid projects.) The WH-348 form should be attached to and submitted to the Project Manager with the contractor's payrolls and kept in the District. The Project Manager should maintain a record of WH-348s and payrolls received. The WH-348 for the last week of work shall clearly indicate that it is the final report.

The contractor and subcontractor are required to submit the payrolls with Form WH-348 weekly. Payrolls shall be considered delinquent when they are not in the Project Manager's hands by the seventh day after the date on which the employees are paid. The Project Manager shall defer the release of progress estimates until contractors comply with this rule. The Project Manager shall notify the contractor by letter of any delinquent payrolls or Forms WH-348 in advance of the estimate date.

Contractor's Statement of Materials and Labor - (Form FHWA-47). Form FHWA-47, "Statement of Materials and Labor", shall be submitted by the contractor as required and explained in Section VI, Record of Materials, Supplies and Labor, Form FHWA-1273 (Rev. 4-93). The FHWA-1273 is included in every Federal Aid project. The contractor shall submit one copy of this report to the Lincoln Construction Division. If this report has not been received when the final records are sent to the Lincoln Office, the Construction Division shall withhold release of the final estimate until the Form FHWA-47 is received.

105.07 FIELD COMPUTATIONS FOR FINAL PAYMENT

General - The quantity of each item of work on the project shall be computed and checked by the Project Manager and their assistants. Computations must be complete so that each step may be easily followed without completely checking the mathematics. The date and initials of persons performing computations and verifications should be shown on each sheet of the field notes, cross sections, and computations. Unless this information is shown, it will be necessary for the work to be duplicated in the District Office.

All computations will then be reviewed in the District Office to determine the correctness of the method used in computing the quantities of the various items. Sufficient checks of the mathematics should be made to determine the care and accuracy used in preparing the computations. A check should be made to determine if all necessary, supplemental and force account agreements have been executed. Considerable discretion must be exercised during the District review in order to ascertain the accuracy of final computations and yet eliminate needless rechecking.

The Construction Division will not check all projects. Only random audits will be performed.

Roadway Excavation - Final earthwork quantities may be computed by either of two methods or a combination of the two methods.

1. **Data Collector** - When the preliminary survey was entered in a Data Collector, then all survey data during and after construction can be modeled with GeoPak. Final cross sections are computed by GeoPak once the final surface shots are input in the Data Collector. Cross sections can be taken at any location by GeoPak.
2. **Planimeter Method** - After the final cross sections have been plotted and checked, the areas of excavation which are enclosed by the original and final cross sections are measured by the planimeter. In using the planimeter, for areas plotted 60 mm (5 feet) to 1 mm (1") horizontally and vertically, each area should be circumscribed twice. The reading at the end of the second circuit should be twice the reading at the end of the first circuit. The planimeter shall be set so that the reading at the end of the second circuit is in square meters (square yards) of end area. Without changing the planimeter setting, areas may also be determined for cross sections plotted vertically 60 mm (5 feet) to 1 mm (1") and horizontally 120 mm (10 feet) to 1 mm (1"). The reading at the end of the second circuit should be twice the reading at the end of the first circuit. The reading at the end of the second circuit should then be divided by 2 for the area in square meters (square yards).

Planimeters shall be checked frequently by running around 4 squares of the cross section paper. Different individuals and different cross section sheets often require different settings of the planimeter arm, and the machine should be checked when changing operators or cross section sheets. Each area should be checked by another person. In checking areas, the following shall be the allowable error:

<u>ALLOWABLE AREA ERROR</u>		
(metric)		
Areas of 3 to 38 m ²		1 m ²
Areas of 39 to 50 m ²	not over	2 m ²
Areas of 51 to 99 m ²	not over	3 m ²
Areas of 100 to 250 m ²	not over	4 m ²
Areas of 251 to 500 m ²	not over	5 m ²
Areas over 500 m ²		1 percent

<u>ALLOWABLE AREA ERROR</u>		
(English)		
Areas of 32 to 400 ft ²		10 ft ²
Areas of 400 to 550 ft ²	not over	20 ft ²
Areas of 550 to 1075 ft ²	not over	30 ft ²
Areas of 1075 to 2700 ft ²	not over	40 ft ²
Areas of 2700 to 5400 ft ²	not over	50 ft ²
Areas over 5400 ft ²		1 percent

All excavation cross sections shall be inspected for closure and, if necessary, a "field check" made. Sections must close in order that the end area may be accurately determined.

If any excavation area occurs on a horizontal curve, it must be corrected for curvature. This correction will be a reduction in area size on the inside of the curve and an addition to the area size on the outside of the curve. If the entire area is a cut section, the correction may be either a subtraction or an addition to the original area size depending on the location of the center of gravity of the cross section. The formula and an example of end area curvature correction for both simple and spiral curves is shown here:

INSTRUCTIONS FOR CORRECTING EARTHWORK AREAS FOR CURVATURE

Excavation areas of cross sections on horizontal curves shall be corrected for curvature using the formula $C = \frac{Ae}{R}$ where:

R

A = the area of the cross section

e = the eccentricity

R = the centerline radius of the curve

The area A is the area of the section determined with a planimeter. The eccentricity is the distance between the centerline or base line of the cross section and the center of gravity of the cross section, and is a positive number when the center of gravity falls outside the centerline, and a negative number when the center of gravity falls inside the centerline. The correction is positive or negative depending upon the sign of the eccentricity.

The center of gravity of the cross section in most cases can be determined by inspection. If the area and the eccentricity are large and the radius small, it may be necessary to determine the center of gravity of the section by the moment arm method, after determining the center of gravity of the smaller portions of the section by inspection.

In determining the center of gravity, it must be remembered that the center of area falls at the center of gravity only when the area is rectangular in shape.

All computations for the correction for curvature may be made with a slide rule.

EXAMPLE

Assume a three degree curve to the left with the following cross section on the curve at Station 100+00.

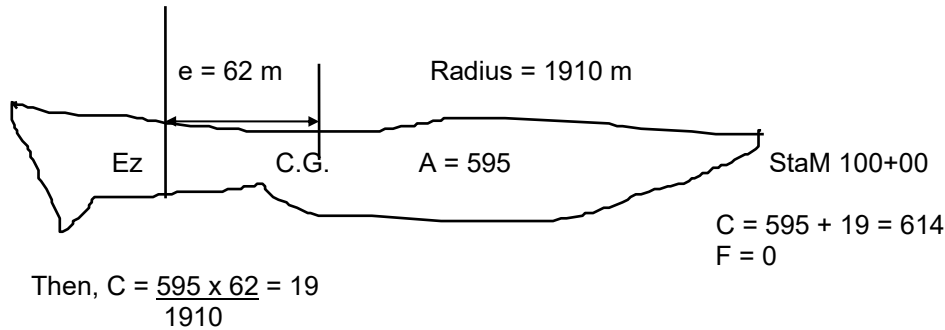

RADIUS COMPUTATION FOR AREAS IN SPIRAL CURVE

When the above area falls in a spiral curve, the radius must be computed for each station and plus using the formula $r = \frac{RL}{1}$ where:

- r = Radius at Required Station on the Spiral
- R = Radius of Main Curve
- L = Length of Spiral
- 1 = Distance from T.S. to Required Station

If the above Station 100+00 is 150 m from the T.S. and given a 300 m spiral, then $r = \frac{(1910)(300)}{150} = 3820$ m, the radius at Station 100+00.

After the excavation areas have been carefully checked, they are transferred to earthwork computation sheets and the volumes of cut areas computed. These need be computed only as far as the fifth column (Sum End Areas Corrected for Distance). The total of this column may be converted to cubic meters (square yards) by multiplying it by the factor 50 (in English units use factor 1.8518519.) Earthwork computations shall be computed to one decimal place (0.1 m³) (0.1 cy). Sheet totals to the nearest cubic meter (cubic yard) should be summarized.

Overhaul - Overhaul will be computed in the Lincoln Office using the mass diagram. When overhaul is involved, the following procedures should be followed by field personnel (See *SSHC Section 209*):

1. Recheck balance to determine that all plan excavation has been incorporated.
2. Recheck embankment to insure that undue swelling or slope flattening has not occurred.
3. Locate additional excavation within the balance if possible.

4. Inform the District Office of the existing conditions and shortages.
5. Take embankment sub final cross sections over the entire area where embankment is deficient. Correlate this area to the project centerline.
6. Take preconstruction cross sections of the new borrow area and correlate it to the project centerline. Should the borrow originate in an adjoining balance, sub final cross sections should be taken to complete the separation of the two balances. Upon completion of the excavation and placement in embankment, final cross sections over both areas (excavation and embankment) are necessary to measure the quantity of excavation moved and in order to compute the overhaul, if any. A diagram of the source and final deposit area with "measured distances" will be very helpful in making the final computations.
7. Transmit all notes, plotted cross sections and computations, diagrams, and pertinent information to the Lincoln Office for analysis and overhaul computations.
8. The Project Manager will be advised of the quantity for payment and all notes, diagrams, computations, and pertinent information will be returned.

Foundation Course - Foundation course may be of several types. It will be noted that *SSHC Subsection 307.04* provides that Foundation Course will be measured for payment by the square meter (square yard) or Megagram (ton) as defined in the Bid Item Schedule. When Foundation Course is measured by determining the mass, it is important that the moisture content be maintained within the limits shown in the specifications in order to avoid payment for extra water in the material. Frequent moisture tests should be made at the time of measurement.

SSHC Subsection 307.04 says moisture content at time of measurement shall be between optimum and 3 percent below optimum.

Gravel Surfacing - Gravel surfacing computations should be submitted on NDOT Form 264.

Since the payment the contractor receives for gravel depends on test results and computations shown on this form, it is extremely important that both the testing and the arithmetic be accurate. Placing information shall be shown in the field books.

"Truck Capacity Computations", NDOT Form 101, are necessary when trucks are hauling such items as gravel, sand, filler, etc. and payment is to be on a cubic meter (cubic yard) basis. This form shall be prepared promptly at the beginning of the work and submitted to the District Office. The type of material being hauled shall be noted on the form.

If trucks are transferred to another project under the inspection of the same Project Manager or inspector during the construction season, it is not necessary to remeasure the trucks or submit NDOT Form 101. However, always inform the District Office of the transfer.

This information should include the name of the owner and license number, capacity of the truck, original project number on which the truck was measured, and the new project number.

Prime Coat and Tack Coat - (See *SSHC Sections 504 and 517*) - Asphaltic materials for prime coat and tack coat shall be measured in liters, corrected to 60°F (15°C). If the material is delivered in tank cars, the quantity is usually determined by measuring the mass or metering at the source. If this is not done at the source, the mass of the material must be measured at the point of delivery.

When material is transported directly to the work in trucks, the mass shall be measured on scales.

If the material has been metered, the volume at 60°F (15°C) shall be determined. (Contact Materials & Tests Division for proper conversion factors.) Any material that is lost, wasted, used on private work, or transferred to other projects shall be deducted. Tank cars and trucks shall be checked to verify that they have been entirely emptied before returning to the refinery.

When asphaltic material is transferred from the project, the Project Manager shall measure the material before it leaves the project and immediately notify the Materials and Research Division that the material is being transferred. The Construction Division and the District Engineer(s) should also be notified. The notice shall be by the NDOT Form 193, Transfer of Asphaltic Material. If possible, it is advantageous for a copy of this report to accompany the transferred asphaltic material.

Asphaltic Concrete Surface Course and Base Course - Tickets may be furnished by the Department or by the contractor. The contractor may furnish the tickets if he/she wishes to use automatic printing equipment. If the contractor desires a copy of the scale tickets, they should be prepared in triplicate. The original should be received by the laydown inspector. The first copy is the contractor's copy, and the second copy is for the project records.

The liters of asphaltic cement shall be measured as shown in *SSHC Subsection 503.05*. (HINT: A common final computation error is the failure to deduct asphalt cement used in wasted asphaltic concrete from the final pay quantity.)

Concrete Pavement - The number of square meters (square yards) of concrete pavement to be paid for will be the plan quantity. Widths and lengths of irregular areas built other than as shown in the plans shall be measured and recorded in a data collector and the areas computed, or computations made from staking data providing no changes occurred during the actual construction. Quite often the plans indicate the quantity (square yards) (square meters) involved in intersections, driveways, and the more complex sections of the projects. In these instances, the quantity indicated on the plans for a given area may be used as the final pay quantity, provided that no geometric changes have been made from those shown on the plans and that a rough check of the quantity shown has been made to determine if any apparent errors exist.

In determining the final quantities for concrete pavement or base course on an area basis, deductions will be made for fixtures in the roadway having an area greater than 1.0 m² in accordance with *SSHC Subsection 109.01, Paragraph 1.b*.

When municipal paving projects involve several items of work for which payment is made on an area or length basis, such as sidewalk, curb, curb and gutter, driveways, pavement, etc., it is suggested that complete sketches be prepared in Microstation or on cross section paper to show the actual work performed as well as the computations for the pay quantities. As a general rule, two complete sets of sketches should be prepared. One set should show the removal items and the other set should show the new work. The measurements and dimensions included with these sketches should be clearly identified as to whether they are actual field measurements or computed dimensions. The computations should always be shown on, or accompany, such sketches.

When municipal paving projects contain various radii curves at street intersections, concrete paving area measurements and computations may be based on the chord and rise method. Dimensions used for final payment will be as staked dimensions. (This assumes any difference is a contractor error.) The only exception would be if the area was constructed smaller than it was staked.

Combination curb and gutter is measured for payment by the linear foot (meter). (*SSHC Section 606*)

Removal of Existing Structures and Preparation of Existing Structures (SSHC Section 203)

1. **Removal of Existing Structures** - Unless the contract contains a unit bid for the removal of an old structure, the excavation necessary for such removal is paid for by the cubic yard (cubic meter). Preconstruction cross sections shall be taken for all removals.

Pipe removal excavation limits are shown in the SSHC in *Figure 701.01*. Headwalls and box culverts may be removed on a unit basis and any removal excavation will be subsidiary. The volume occupied by them within the limits of the new work shall be included for payment as culvert excavation. However, deductions will be made for openings in structures, other than pipe and pipe-arch culverts, if the openings have an average cross sectional area over 21.5 square feet (2.0 m²). This means the nominal opening of the old concrete box regardless of the accumulated silt and debris. On old structures without paved floors, the PM shall measure and compute the average cross sectional area of the opening. (See SSHC Subsection 702.04.)

In the case of removal of old pipe and headwalls, where the headwall is removed on a unit price basis, the excavation limits for the old pipe removal will extend 500 mm (18 inches) beyond the end of the pipe the same as would be applicable if no headwalls were involved. Any necessary excavation for removing the old headwalls outside the pipe excavation limits would still be subsidiary. (See SSHC Subsections 702.04 and 702.05)

2. **Preparation of Existing Box Culverts** - When the contractor has the option of breaking the box culvert back 2 feet (600 mm) or drilling dowel holes to insure a structural tie, the concrete and excavation pay item quantities shall be only the volume from the vertical plane that would be necessary for the doweling procedure. When the plans stipulate or the Project Manager orders removal of 2 feet (600 mm) of the box culvert barrel then the pay quantities shall be computed from the vertical plane 2 feet (600 mm) into the existing structure.

The excavation limits are to be computed as shown in SSHC in *Figure 701.01*.

Excavation for Structures

1. **Excavation for Bridges** - Excavation for bridges is computed in the Bridge Division at the time the plans are prepared. Payment is a lump sum for all abutments, piers or bents. No further computations need be made on this item unless the station location of the bridge or the depth of the footings is changed. The Project Manager should not change the location of any bridge without first consulting with the District Engineer, and the Bridge Division.

If it is decided that a change in location is necessary, any required information should be forwarded to the Bridge Division, via the Construction Division, for use in determining the updated excavation quantity.

2. **Concrete Seal Course** - The construction of concrete seal course or removal of unsuitable material is extra work (see SSHC Subsection 702.05). These amounts shall be listed in the field book. The concrete seal course quantities shall be negotiated before the contractor begins the work.

The cubic yards (cubic meters) of concrete in the seal course shall be paid for as indicated in SSHC Subsection 704.05.

3. **Excavation for Culverts**

- a. **General** - The Project Manager should be thoroughly familiar with *SSHC Section 702*, "Excavation for Structures", before measuring or computing the contractor's culvert quantities.

Following are listed some of the various classes of culvert excavation listed for payment in State contracts: "Excavation for Pipe Culverts and Headwalls", "Excavation for Box Culverts", "Excavation for Inlets and Junction Boxes", "Excavation for Sewers", etc. Since these are separate items in the contract, they should be kept separated in the field notebooks and computations. Include sufficient information in the field notebook so this separation may be checked during final review. If the plan data calls for removing a pipe culvert and building a box culvert at the same location, the excavation for removing the pipe culvert and headwalls would be determined as if no box culvert were to be built at the removal location. Any duplicated or overlapping excavation would be deducted from the volume of excavation for the new box culvert.

- b. **Typical Channel Section** - When the plans show a typical channel section through a culvert site, the separation of grading and culvert excavation should be handled as follows:

Slope stake the typical channel section through the culvert site.

Take final cross sections after the channel dirt is removed.

Do not pay for any of the excavation twice.

- c. **Excavation for New Structures.**

Field Measured Culvert Excavation - In general, the Project Manager shall bear in mind that:

There shall be no duplication of excavation when headwalls are constructed.

No additional excavation will be allowed for concrete elbows. This is a minor amount and since the kind of pipe is usually optional with the contractor, the excavation quantity will be based on the use of corrugated metal pipe.

The contractor is entitled to payment to the excavation limits specified even though he/she may not actually remove the soil to those limits. However, in all cases, the contractor should be held to a width adequate for proper compaction of the backfill beneath the lowest 90 degrees of pipe culverts and adjacent to all pipe-arch culverts at the widest dimension. If slope is not properly laid back, other safety precautions must be taken to protect people from a cave-in.

Following are the excavation limits to be used in computing the contractor's culvert excavation. Since these limits are fixed by the specifications, final computations may be completed at any time after taking the preconstruction cross sections.

Box Culverts - 450 mm (18 inches) outside of the neat lines of the concrete to the bottom of the box floor or footings. On box curtain walls below the bottom of the floor and the footing beneath the lower break of broken back boxes, the excavation shall be the same as the neat lines of the concrete curtain wall or footing.

Pipe Culverts - the nominal inside diameter of the pipe plus 3 feet (1 meter), and 18 inches (450 mm) beyond the end of the pipe and to the flowline of the pipe.

Pipe Arches - the maximum nominal inside clear span dimension on the arch plus 3 feet (900 mm), and 18 inches (450 mm) beyond the end of the pipe and to the flowline of the pipe.

Concrete Headwalls - 18 inches (450 mm) outside the neat lines of the concrete and to the bottom of the headwall. If it is necessary to construct compacted embankment to the flowline elevation before laying the pipe, headwall excavation shall be allowed from the flowline of the pipe to the bottom of the headwall.

Concrete Elbows, Collars, and Collars with Bend - the excavation limits for elbows and collars is the same as for pipe culverts without elbows, collars or collars with bend.

All the above limits are increased when flowline is more than 4 feet (1.25 m) below natural ground. There is an additional allowance for safe excavation. See *SSHC Specification Figure 701.01*.

Piles and Pile Driving

The Project Manager shall measure all piling to ± 0.10 foot (30 mm) before they are placed in the leads by the contractor. Cutoffs shall also be measured to ± 0.10 foot (30 mm).

Sheet Piling - The quantity to be paid the contractor for this item is the number of square yards (square meters) of piling remaining in the completed structure, except that no payment shall be made for lengths in excess of those ordered by the Project Manager.

For steel sheet piling, the computation width shall be the manufacturer's nominal driving width of each sheet, in accordance with *SSHC Subsection 703.04*. This has been interpreted to mean in the case of bent sections for corners, the nominal width of the sheet before bending regardless of angle of bend. The quantity of steel sheet piling cutoff to be paid for shall be in accordance with *SSHC Subsection 703.05* and shall be verified by the inspector in the bridge book.

The computation width for concrete and timber sheet piling shall be the nominal width shown on the plans. For timber sheet piling in sloping wingwalls, the contractor shall be allowed payment for the square meters (square yards) of piling remaining in the completed wingwall, plus payment as cutoff for the square meters (square yards) cutoff to make the slope. The combined length of pile and cutoff shall not be in excess of the plan order length or revised length ordered by the Project Manager.

In order to determine the final pay quantity for these items, it is essential that the total length, the length of cutoff and the net length remaining in place be shown in the field notebook for each sheet pile. All measurements shall be ± 30 mm (0.10 foot) and in the case of wing piling cutoff on the slope, the length of cutoff should be the average of the long and short sides.

The field notebook for the bridges shall include definite information as to the final quantities for all contract items even though a number of the items may have the same final quantity as listed in the contract. Final quantities shall be summarized in the field notebook. This eliminates questions on the part of the reviewer as to the correct final quantity.

Concrete Construction and Reinforcement - Pay quantities for these two items are computed from tables found on the standard plans. Plans for special structures also contain this information.

The Project Manager shall not make a deduction from the concrete quantity shown on the standard headwall plan when the pipe enters the headwall on a vertical (broken back pipe) skew.

In computations for concrete quantities for junction boxes and inlets, the deductions for pipe openings shall be computed on the basis of right angle openings even though the actual opening may be on a skew. No correction shall be made for shell thickness of concrete pipe culverts.

Culverts

1. **Concrete Pipe Culverts** - The contractor's payment for concrete pipe is based on a measurement of the actual length of pipe in place, but in no case will a length greater than order length be submitted for payment.

When elbows are required, the measurement shall be continuous through the elbow. The additional allowance for elbows is provided in *SSHC Subsection 718.04*.

When either prefabricated or field constructed elbows connect two sections of new pipe, the pay length of the elbow will be the measured length on the longitudinal axis of the pipe (average of the long and short sides), plus the allowance (depending on the diameter) listed in the specifications or as amended by the Special Provisions. No payment is allowed for the concrete and reinforcing steel used to construct the elbow.

If the elbow, poured in place, connects old and new pipe, it will be considered as a collar with a bend and no payment will be included for the elbow as such. In lieu thereof the concrete and steel required for the elbow will be included for payment under the items of concrete and reinforcing steel for collars.

The measurement for payment of all the types of culvert pipe is based on the number of linear meters (linear feet) in place and accepted. This is interpreted to mean that culverts are to be measured after material has been cut off for skewed ends. Thus payment is not made for waste resulting from skew angle cuts on either one or both ends of a culvert.

3. **Corrugated Metal Pipe and Pipe Arch Culverts** (*SSHC Subsection 718.04*)

Corrugated Metal Pipe - The contractor's payment for corrugated metal pipe is based on a measurement along the longitudinal axis of the pipe and payment will not be made for lengths greater than order length.

When elbows are required, the measurement shall be continuous through the elbow. To the measured length of each elbow shall be added the additional allowance provided in *SSHC Subsection 718.04*. The pay length of the elbow will be based on the centerline distance.

If field connections are required for the extension of existing corrugated metal pipe, the contractor shall receive payment for the necessary connecting band. When the Project Manager makes changes in their original pipe order after it has been fabricated, the contractor shall receive payment for any connecting bands made necessary by such changes. (See *SSHC Subsection 718.04*)

Corrugated Metal Pipe Arches - Corrugated Metal Pipe Arches shall be measured for payment in the same manner as corrugated metal pipe culverts along the flowline of the pipe-arch. Include elbow and skewed end dimension sketches in the notebook.

Pipe Ordered But Not Used - The quantity of various pipe items is shown on the Project Manager's field checked culvert list, the testing laboratory's delivery

records and in the final summary. These three records should be in agreement or any differences fully explained before submitting the final estimate.

If any pipe is delivered but not installed, due to a change in plans, this should be recorded in the notebook and the project records shall show the final disposition of the pipe. If the pipe is transferred to the maintenance department, it shall be included for payment on the final estimate under "Contingencies" nonparticipating.

For roadway pipe and driveway culvert pipe, payment shall be made to the contractor on the basis of their actual delivered cost to the project plus a handling charge of 10 percent. A supplemental agreement shall be executed to establish this price which must be substantiated by a copy of the contractor's invoice attached to the agreement.

Notify the District Office or the Maintenance Superintendent who will arrange to pick up the pipe and issue a requisition crediting the project and charging the supply base. Advise the person issuing the credit requisition of the name of the contractor and unit price to be used in making the credit and charge.

3. **Culvert Pipe** - Some pipe items are "required" in the sense that the contractor must furnish definite types and sizes of pipe if stipulated in the plan and in the bidding proposal. A required pipe is one that the plan definitely states the type and size of pipe to be furnished. This may be an extension of an existing pipe so that the contractor must furnish the same type and diameter. The plans may definitely require a corrugated metal pipe - arch at some location due to low head clearance under the project road, or any type or size necessary due to some special construction feature of the project.

All other pipes are listed in the bidding proposal as "Culvert Pipe". The contractor may furnish any of the types of pipe listed in *SSHC Subsection 718.02*.

Quantities of pipe that are "required" by the plans or are "culvert pipe" shall be separated in the notebook and computations. "Required" and "culvert pipe" prices may be interchanged to some extent. For example, if the contract contains a bid price for 2 feet (600 mm) culvert pipe and it develops that an existing 2 feet (600 mm) pipe must be extended, it will be permissible to include the extension for payment under the contract item for 2 feet (600 mm) culvert pipe, provided the extension is the same type of pipe the contractor has chosen to furnish. This interchange of prices is not permissible between roadway and driveway pipe items.

Flared end sections which are called for in the plans on either concrete or metal pipe shall be furnished, installed, measured and paid for in accordance with *SSHC Section 723*.

Sewers (*SSHC Section 722*)

1. **Excavation** - Sewer excavation is subsidiary to the sewer pipe pay item.
2. **Pipe Computations** - Sewer pipe is measured for payment as described in *SSHC Subsection 722.04*.

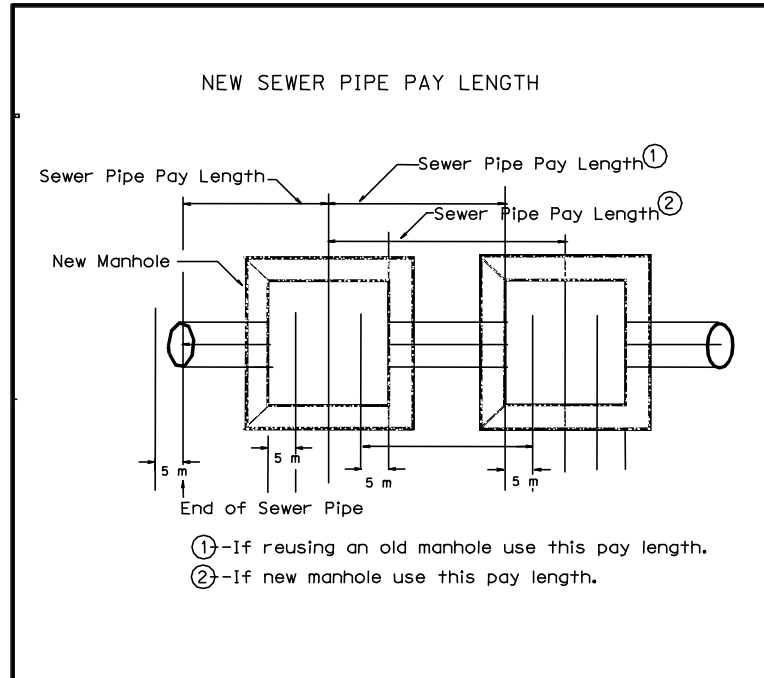

Guardrail - The contractor shall be allowed payment for linear meters (linear feet) of guardrail complete in place measured from center to center of end posts (*SSHC Section 902*).

105.08 BORROW AND LOCAL PIT MATERIALS OBTAINED BY THE CONTRACTOR

Under State Option - All amounts to be paid by the contractor for royalty and borrow costs, to comply with the terms listed in the option block shown in the plans, will be deducted from the payment due on the final estimate. Such amounts will also be included in the retention in the additional estimate. This Department will make payment directly to the owner. Before such payment can be made, it will be necessary to obtain concurrence from the contractor as to the quantities and amounts in order to eliminate the possibility of overpayment to the owner. For this purpose, the Project Manager shall prepare and forward a letter to the contractor.

The receipt of such letters from the Project Manager and contractor, plus the required releases from the pit owners, will complete the records required by the Right of Way Division to enable them to make payment to the owners of local pits. In the case of borrow, taken on an acreage basis, sketches are to be prepared showing the dimensions of the individual pits, the name of the owner, the description of the land subdivision, ties with the project centerline and computations for the acreage included in the letter to the contractor. Such sketches shall be forwarded to the Right of Way Division together with their copy of the letter to the contractor.

When the option block in the plans for the local pit includes payment for incidental items such as temporary fencing, reseeding, crop damage, payment for haul road, etc., the consideration for such incidental items will normally be on a lump sum basis and the lump sum payment for such items shall be included in the letter to the contractor. If payment is stipulated in the option block, for such incidental items, on other than a lump sum basis, the Project Manager shall request the Right of Way Division to advise the proper method of handling the item.

When work is to be suspended for the winter season, or for any other reason, for a considerable length of time and it is desirable to make partial payment to the landowners, the necessary information to authorize partial payment shall be forwarded to the Right of Way Division and, in such cases, it is not necessary to advise the contractor. In the event that a section of the project, involving optional borrow pits, is completed or the work is completed on some of the local pits, the normal letter to the contractor should be prepared in which it shall be noted that information will be forwarded at a later date for the remaining borrow or material pits.

In order to complete the records and eliminate any questions, the Project Manager's letter to the contractor must cover all optional borrow and local pits shown in the plans, regardless of whether they are actually used.

There have been some cases where a pit under state option does not appear on the plans for a particular project but does on an adjacent project. The contractor, if he/she uses this pit, must still be responsible for royalty payments.

Royalty payments for local pit material will normally be made on a cubic meter (cubic yard) basis and such quantities may be determined by preconstruction and final cross sections. In cases where payment to the contractor is based on truck measurement the royalty payment may be based on the same measurement, or by using weight conversion factors where payment to the contractor is based on units of mass.

Borrow and Local Pit Materials Furnished by the State or County and Not Involving the Contractor - When borrow or local pit materials are purchased from the owner directly by the Department or County, and no option requirements involving the contractor are included in the plans, substantially the same information must be forwarded to the Right of Way Division. However, no letter needs be written to the contractor. The PM must obtain a site release from the landowner on these Department obtained borrow sites.

105.09 SUMMARY OF FINAL QUANTITIES

Project Managers are required to use only black lead pencils in the original preparation and checking of all field records and final computations in the field offices. The District Office review should be indicated by red check marks, initials and dates. Corrections shall be made with red pencil. If any further changes or corrections are found necessary in the Lincoln Office, they will be made in blue or green pencil. This method will eliminate any question at some future date as to where changes or corrections in the records originated.

Each pay item in the contract must be summarized in SiteManager or other approved documentation.

105.10 MOBILIZATION (SSHC Section 112)

Method of Measurement and Basis of Payment

The percent of payment for mobilization under a group of work is based on the percent of work completed on the original contract group amount. Accordingly, when two or more projects are included in the contract and work has been performed on only one project the quantity for mobilization should be paid to all projects based on the percent of work completed on the original contract group amount. In this case mobilization may be paid on a project when no work has been performed on the project.

105.11 SALVAGED PROJECT MATERIALS REPORTING

Many project plans indicate that some removal items shall be stockpiled or salvaged to a nearby maintenance facility.

106.00 PROJECT FINALIZATION

106.01 FINAL PAYMENT TO CONTRACTOR

NDOT policy is to retain one percent. This retainage is specifically withheld to cover:

- The amount of any possible overpayments or adjustments to contract items and change orders discovered during an audit (State or FHWA).
- Any assessed liquidated damages.

Nebraska Code also requires payment of interest on retained contract funds. The interest shall begin to accrue on retained funds on the 61st day after the project is complete provided all of the contractor's documents are on file with the Department.

106.02 PRICE ADJUSTMENT CHANGE ORDERS

Price adjustment deductions are processed by change orders. If additional price adjustments come up later, a second change order must be prepared; but such increases or decreases are processed as separate change numbers.

106.03 EQUIPMENT PURCHASED BY CONSTRUCTION CONTRACTS

Occasionally, items of equipment are shown as contract items and then taken into the Department's inventory when their use on the project is no longer required (variable message boards, for example). It is required that the contractor be given written confirmation when such equipment is ultimately received and title transferred to the Department.

In order to provide an adequate audit trail, it is required that the letter of confirmation should include detailed information regarding brand, model, serial number, date of transfer, current location and a statement indicating the condition of the equipment when title was transferred.

A copy of the letter of confirmation should be forwarded to the Operations Division (in addition to your normal distribution of project correspondence) so that it may initiate the appropriate paperwork reflecting addition of the equipment to the Department's inventory.

106.04 PROJECT ACCEPTANCE AND AUTHORIZATION FOR FINAL PAYMENT

The Final Estimate when signed by the Construction Engineer is authorization to the Controller's Office to release the final payment to the contractor.

Notification of Project Completion (NDOT Form 91) - All Projects

The Project Manager will prepare an acceptance letter and forward it to the DCE to notify the contractor of tentative acceptance.

The NDOT Form 91 (Notification of Project Completion) should not be prepared and distributed until the work is really done --- such as when a 180-day observation period is required on paint. Wait until the 180 days have past, then determine if all work is acceptable, and then complete the form.

The Controller Division uses the form to trigger final payments, so they want work which the county or city promised to do included in the definition of "complete." They explain that although the local government may have performed the work, the value of that work is included in their bookwork and subsequent notification to the FHWA.

Immediately after completion and acceptance of a contract, the DCE/DE will prepare and sign a NDOT Form 91.

The NDOT Form 91 shall be completed promptly and forwarded to the District Engineer. In essence, this means construction work is complete and the contractor does not need to come back. However, processing NDOT Form 91 should **NOT** be held up waiting for finalization of paperwork, including material certifications or "Change Orders."

- Preparing a "Notification of Project Completion" (NDOT Form 91) is self-explanatory. All applicable blanks are to be completed.
- The DCE/DE, after signing NDOT Form 91, shall forward it to the FHWA, as applicable. Distribution within NDOT is shown on the form.

106.05 FINAL PACKAGE

Refer to the [Final Review Process Manual](#) to finalize a project and determine documents to forward to the Construction Division.

106.06 FINAL COMPUTATIONS

When submitting final computations for any project, there shall be a statement by the District Engineer to the effect that any and all trucks which hauled materials, incorporated into the work on a volume basis, have been measured, computed and checked for volume specified.

106.07 ACCEPTANCE AND FINAL PAYMENT

Final Inspection and Acceptance - The District Engineer shall make the final inspection of the project. Generally, the contractor will be required to complete all items of work included in the contract before the final inspection and total acceptance of all contract work is made. However, it is the Department's policy to make a tentative acceptance of completed groups of a contract which have a separate time allowance. This tentative acceptance relieves the contractor of maintenance responsibilities for such groups. It does not relieve the contractor of the liability for any damage to the completed work caused by their operations in completing the remaining groups of work, or the liability for any defective work discovered in any item of groups of work prior to final acceptance and payment.

Before advising the District Engineer that final inspection of the project is desired, the Project Manager shall make a careful inspection of the work with the contractor's superintendent. He/she shall direct the superintendent's attention to any additional work which he/she considers necessary before the final inspection is made. He/she shall also make certain that the contractor has complied with *SSHC Subsection 105.12* regarding the contractor's use of land obtained by the Department.

After the work has been completed, the District Engineer shall within one week advise the contractor in writing that the work is tentatively accepted by the Department. The Project Manager shall include in the acceptance letter a list of documents that are missing.

In the event the Federal Government is participating in the work, the District Engineer shall notify the Division Administrator of the Federal Highway Administration immediately upon completion of the total contract or direct labor project agreement items on any project. This report shall give the actual date that all contract work was completed. If any direct labor work, such as a reflectorized railroad crossing signs, etc., which are a part of the detail estimate, are constructed later, the date of their completion becomes the completion date for the project.

The PM must notify the Construction Division when a project is complete. In SiteManager, the PM must send an email note to "NDOT Const-Completion Notification." The Finaling Manual explains what must be included in the "note."

Interest Payments on Delayed Estimates - State law provides that, "if the contractor has furnished the Department all required records and reports, the Department shall pay the contractor interest on the amount retained and on final payment due the contractor beginning the sixty first day after the work under the contract has been completed, as evidenced by the completion date established in the department's letter of tentative acceptance, and running until the date when payment is tendered to the contractor.

The contractor is allowed fourteen calendar days from the date of notice as evidenced by the date of the letter of notification to:

1. Reply to the project manager's written notification of optioned pit material quantities and costs involved in a project (such reply shall be directed to the Department's Right of Way Division).
2. Provide signed records or documents, such as Change Order – Supplemental Agreements, requested in writing by the Department.
3. Provide all required records and reports, such as payrolls, material certifications, etc., requested in writing by the Department.

In the event the time interval stated above is exceeded, deductions to the interest time period will be made for the actual number of days to complete the action which occur beyond the original sixty calendar days.

It is essential that the acceptance letter include the correct completion date which shall be in agreement with the completion date as shown in the Project Manager's weekly working day and progress reports. This date will be the last day on which any work is performed on the project, and may be several days after the last working day charged. This condition will occur when minor finishing or cleanup work is required prior to tentative acceptance.

In order to eliminate or minimize interest payments and provide adequate time for processing through the various NDOT Headquarters, it is essential that the final records be completed and reviewed in the District Office as soon as possible after the actual completion date. This will require that the final measurements and computations be completed to the greatest extent possible during the time that construction is in progress and will require the taking of final cross sections for grading work (only when plan quantities are disputed) as early as possible. In some Districts, the volume of grading work will undoubtedly require the organization of "floating" parties to take final cross sections, which will require adequate District planning in advance of the need for such parties.

106.08 FINAL RECORDS

In the event the Federal Government is participating in the work, the District Engineer shall notify the Division Administrator of the Federal Highway Administration immediately upon completion of the total contract or direct labor project agreement items on any project. This report shall give the actual date that all contract work was completed. If any direct labor work, such as a reflectorized railroad crossing signs, etc., which are a part of the detail estimate, are constructed later, the date of their completion becomes the completion date for the project.

The PM must notify the Construction Division when a project is complete. In SiteManager, the PM must send an email note to "NDOT Const-Completion Notification." The Finaling Manual explains what must be included in the "note."

Interest Payments on Delayed Estimates - State law provides that, "if the contractor has furnished the Department all required records and reports, the Department shall pay the contractor interest on the amount retained and on final payment due the contractor beginning the sixty first day after the work under the contract has been completed, as evidenced by the completion date established in the department's letter of tentative acceptance, and running until the date when payment is tendered to the contractor.

The contractor is allowed fourteen calendar days from the date of notice as evidenced by the date of the letter of notification to:

1. Reply to the project manager's written notification of optioned pit material quantities and costs involved in a project (such reply shall be directed to the Department's Right of Way Division).
2. Provide signed records or documents, such as Change Order – Supplemental Agreements, requested in writing by the Department.
3. Provide all required records and reports, such as payrolls, material certifications, etc., requested in writing by the Department.

In the event the time interval stated above is exceeded, deductions to the interest time period will be made for the actual number of days to complete the action which occur beyond the original sixty calendar days.

It is essential that the acceptance letter include the correct completion date which shall be in agreement with the completion date as shown in the Project Manager's weekly working day and progress reports. This date will be the last day on which any work is performed on the project, and may be several days after the last working day charged. This condition will occur when minor finishing or cleanup work is required prior to tentative acceptance.

In order to eliminate or minimize interest payments and provide adequate time for processing through the various NDOT Headquarters, it is essential that the final records be completed and reviewed in the District Office as soon as possible after the actual completion date. This will require that the final measurements and computations be completed to the greatest extent possible during the time that construction is in progress and will require the taking of final cross sections for grading work (only when plan quantities are disputed) as early as possible. In some Districts, the volume of grading work will undoubtedly require the organization of "floating" parties to take final cross sections, which will require adequate District planning in advance of the need for such parties.

106.08 FINAL RECORDS

Introduction - The Project Manager shall prepare and submit, at the earliest possible date, all necessary records to expedite payment to the landowners along the project for right-of-way, channel changes, borrow and local pit materials, as provided in the various contracts and options as applicable to the project. Prompt payment to landowners will create good will and help in future right of way negotiations. NDOT Form 232, "Final Status Material and Site Releases" is to be prepared and submitted with the final records for each contract.

Right of Way - No measurements or computations need to be submitted for right-of-way as payment will normally be made for right of way prior to the actual construction, in accordance with the terms of the right of way contract. Any requirement for additional right-of-way shall be submitted to the Right of Way Division, through the District Office, for their further handling.

Crop Damage - The acquisition of right of way and subsequent construction often results in crop damage claims being made by the landowner. In order that information is available to settle these claims, the following should be recorded for all growing crops within the right-of-way, borrow, local pit and channel change areas.

1. A sketch showing the boundaries of each tract within station locations, angles, and distances as necessary to locate the tract accurately with reference to project centerline and to compute the area. The tract should be identified by the owner's name and tenant (if any).
2. If the tract is subdivided with more than one type of crop, show the subdivision of tract into fields as necessary to locate the limits of each crop. Information shown should be similar to that required for the tract. Indicate the type of crop growing in each tract or subdivision.
3. Show date of measurement and the name of the person making the measurement.
4. As construction progresses, record for each tract whether the crops are harvested by their owners or are destroyed by the contractor's operations. If harvested, the date of harvest should be recorded or if this date is not known, the date that the contractor began work in the area and a notation indicating that harvesting was complete should be recorded. If the crop in an area is only partially destroyed, the damage should be noted or sketched in a manner such that the area of damage can be determined.
5. The right of way contracts and condemnation descriptions should be reviewed carefully with respect to the provisions pertaining to crop damage. Crops planted after contract has been signed will not be eligible for reimbursement.
6. Crop damage for each tract is to be reported by letter to the Right of Way Division with a copy to the District Engineer as soon as the disposition of the growing crops on that tract is complete. The report should contain the information listed above along with computation of the area in acres, and the legal description of the property (section or part, township and range).
7. Many times, the District Office files do not contain copies of the Certified Analysis of Asphalt Material received on the projects and it is requested the Project Managers include their copies with final computation when transmitted to the

District Review Section. When they have served their purpose they will be returned.

Alternate Crop Damage Procedure

The Right of Way Division is leaving the way to present the crop damage payment up to the Project Manager. If the acreage is between 1/4-acre increments, go to the higher increment. 1/4 acre will be the minimum.

If the farmers accept the affidavit price, payment will be made within a few weeks. If they do not accept the affidavit price, payment will not be made until the crop is harvested and sold.

If the Project Manager runs into a crop that is not covered or the amount is not agreeable, make the measurements of the field and forward them to the Right of Way Division. They will in turn send them an affidavit asking for the average yield for the rest of the field, and the price they were paid when the crop was sold, minus harvesting and marketing costs.

The sources of information used in determining the average yield, average price, and the average cost were obtained from the Cooperative Extension, Institute of Agricultural and Natural Resources, and the Farm Custom Rates, University of Nebraska.

CROP	1/4 Acre	1/2 Acre	3/4 Acre	1 Acre
Irrigated corn	\$75.00	\$150.00	\$225.00	\$300.00
Dry corn	\$40.00	\$ 80.00	\$120.00	\$160.00
Irrigated soybeans	\$62.00	\$124.00	\$186.00	\$248.00
Dry soybeans	\$48.00	\$ 96.00	\$144.00	\$192.00
Wheat	\$31.00	\$ 62.00	\$ 93.00	\$124.00
Oats	\$21.00	\$ 42.00	\$ 63.00	\$ 84.00
Milo	\$32.00	\$ 64.00	\$ 96.00	\$128.00

Alfalfa was not included because the variables of age and cuttings affect the averages greatly. Other crops (beets, edible beans, potatoes, etc.) were not included because of insufficient information.

The schedule will be revised periodically. Any questions or comments should be referred to the Property Management Section, (402) 479-4770.

Conversion of Existing Direct Measurement Earthwork Pay Items to Established Quantity Pay Items

Certain earthwork items may be converted from being direct-measured for final payment to being paid as established quantities. This policy is to expedite the release of final payment to the contractor, reduce possible interest payments to the contractor, and relieve a portion of the workload performed by field personnel.

The following items of work will be eligible for conversion:

1. Excavation
2. Excavation, Borrow
3. Other earthwork-related items when approved by the Construction Engineer

Direct-measurement items may be converted to established quantities when the following requirements are met:

1. The project has been staked and built according to plan, or the plan quantity has been adjusted to account for field changes.
2. The plan quantity has been adjusted for any obvious errors, and the contractor has been notified of the adjustment.
3. The Project Manager has made written notification to the contractor of the proposed change in the method of measurement, and the contractor has agreed to the proposal in writing.
4. If the contractor has agreed in writing to accept plan quantity including field adjustments and revisions, it is not necessary to create a new "established quantity" pay item. Payment will be made under the original contract item.

Sample Letter

1997

CROP DAMAGE PAYMENT AFFIDAVIT

Project:

Tract:

This is to certify that I, the undersigned, agree on the amount of \$ _____ which is being paid for _____ (acres) of _____ damaged during construction, based on the schedule prepared by the State of Nebraska, Department of Transportation.

Owner/Tenant

Social Security #
Federal Identification #

THE CROP PRICES HAVE BEEN COMPILED USING DEPARTMENT OF AGRICULTURE AND UNIVERSITY OF NEBRASKA STATISTICS. THE PRICE REFLECTS AVERAGE YIELDS AND MARKET PRICES LESS THE COST OF HARVESTING AND MARKETING.

CROP	1/4 Acre	1/2 Acre	3/4 Acre	1 Acre
Irrigated corn	\$75.00	\$150.00	\$225.00	\$300.00
Dry corn	\$40.00	\$ 80.00	\$120.00	\$160.00
Irrigated soybeans	\$62.00	\$124.00	\$186.00	\$248.00
Dry soybeans	\$48.00	\$ 96.00	\$144.00	\$192.00
Wheat	\$31.00	\$ 62.00	\$ 93.00	\$124.00
Oats	\$21.00	\$ 42.00	\$ 63.00	\$ 84.00
Milo	\$32.00	\$ 64.00	\$ 96.00	\$128.00

Project Manager

Date

106.09 STATEMENT OF MATERIALS AND LABOR

A "Statement of Materials and Labor" (Form FHWA-47) is required for federal-aid projects that have contract cost (including change order adjustments) of \$1,000,000 or more. Detailed instructions for completing Form FHWA-47 are on the back of the form. Blank forms are available from the Construction Division.

Upon contract completion, each subcontractor must submit a completed Form FHWA-47 (Part "B") to the prime contractor. Subcontractors shall include their name and the word "sub" in the blank space at the top of the form.

The prime contractor shall combine the data from each subcontractor with their own data on one form. Prime contractors shall include their name in the top margin of the "combined" form, note the form is "combined", and attach a listing of all subcontractors involved.

When completing Part "B," contractors shall:

- Report only use of material items that are listed on the form.
- Pay attention to the "units" being requested. "Quantity" entries must correspond to the form's "units."
- Enter required information in the correct column(s).

Prime contractors are responsible to furnish the Construction Division Headquarters (Lincoln) three completed FHWA-47 "packets" before a final pay voucher can be processed. (One packet shall be the original and two packets may be photocopies of the original.) Each FHWA-47 "packet" shall include:

- The prime contractor's combined contract information
- All FHWA-47 forms and any relevant supporting documents furnished by subcontractors.
- Composite of all subcontractors listed on subcontractor request form(s)

Upon receipt of FHWA-47 forms, the Construction Division shall complete Part "A" and verify that:

- An item of material used by a contractor has not been omitted.
- All "starred" line items have received a response or entry.
- Costs reported are reasonable and do not have obvious errors.
- The prime contractor has included required information from all subcontractors on the "combined" form.

106.10 AS-BUILT PLANS

An extra set of full size plans will be furnished the Project Manager for use as as-built plans. The Project Manager may request an additional set of plans from the Construction Division for as-builts if needed. The as-built plans shall be an exact representation of the completed work. Any revised plan sheets must be included and the sheets they replace should be discarded. All special plan sheets must be included. The S1 sheets need to be corrected to show the Final Quantities including additional items of work.

In preparation of these plans, only black pen shall be used. Lines, dimensions and notations shown in the original plans which have been eliminated or corrected shall be

"X ed" (crossed out) and boxed with solid lines. Dashed lines shall be used to indicate any as-built lines, dimensions, or tie points which do not conform to the original plans. For example, a 2' x 65' 8" (600 mm x 20.0 m) pipe culvert is constructed at Station 103+50, whereas the plans called for a 2' x 63' 3" (600 mm x 19.25 m) pipe culvert at Station 101+50. The outline of the culvert at Station 101+50 shall be boxed and the notations describing the work "X ed" within the box with solid lines. The outline of the as-built culvert, in dashed lines, and corrected description notation should be shown at Station 103+50. In striking out figures and notations, care should be used to avoid obliterating the original figures.

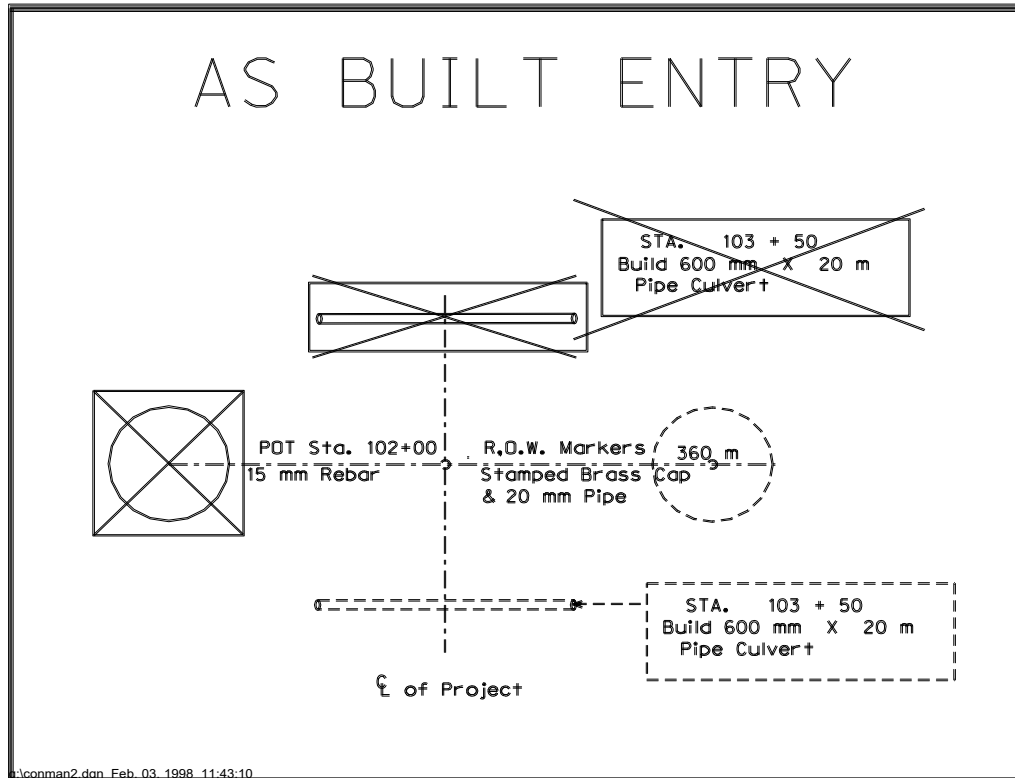

In the event appreciable errors are noted in the locations of side roads, section lines, property fences, buildings, roadway structures, or other important landmarks, the corrected locations shall be shown.

The front sheet shall bear the following label in some convenient blank space:

AS-BUILT PLANS

Work performed by.....(Name of Contractor)

(If more than one contract has been let to complete the work, list all prime contractors)

Prepared by.....(Name).....(Title).....(Date)

Approved by.....(Project Manager).....(Title).....(Date)

The following information shall be shown for the various types of work:

Grading:

1. All changes in alignment.
2. All equations in stationing used during construction.
3. All permanent references for control points. Also, all control points required to establish centerline shall be perpetuated. Brass caps and pipe are available for this.
4. All changes in grade lines and elevations.
5. Locations and elevations of all benchmarks used during construction or permanently established in taking final cross sections. Permanent benchmarks should be identified by the word "Permanent". Benchmarks shall be established at box culverts, bridges and other locations where they may be considered permanent.
6. Location and number stamped on brass disc of all Government Survey benchmarks. The elevation based on the project level datum, if available.
7. Location of all right-of-way markers installed.
8. Location of all land corner witnesses, existing, or installed by the Project Manager.
9. Location of all farm entrances constructed showing lengths, diameters and type of culverts laid or re-laid.
10. Locations of limits of construction of all borrow pits, channel changes, dikes, intercepting ditches, etc., outside the right-of-way not covered by extended roadway cross sections. The stationing and location of the base line with respect to the project centerline shall also be shown.

Culverts:

1. All changes in location.
2. All changes in lengths or dimensions.
3. The type of pipe installed (CMP, RCP, etc.).

Bridges and Special Culverts:

1. All changes in stationing.
2. All changes in design.
3. All revised dimensions.
4. Floor and bridge seat elevation of bridges.
5. Maximum and minimum length of piling in each footing.
6. The description, location and elevation of all permanent benchmarks.

Surfacing:

1. Beginning and ending stationing of each type and width of surfacing constructed.
2. Location of all option pits used in connection with the construction of the project. If any plan pits are not used, designate by the words "Not Used".

Processing As-Built Plans

1. Project personnel will prepare one (1) full-size set of As-Built.

2. Cities, counties, etc. that have money involved or a special interest in the project will be asked by the Project Manager if they need/want a complete copy of the As-Builts or only specified sheets.
3. The As-Builts will be submitted to the Construction Division with the final records for finaling with notification of the number of complete copies or specified sheets desired.
4. The final review will be performed.
5. After the final review is completed, the specified sheets or complete copies, as requested by the District, will be copied in half-size sets. The copies will be returned to the District within three (3) to four (4) weeks after submittal to the Construction Division.
6. The full-size set of As-Builts will be submitted to the Communications and Public Policy Division for microfilming after the final review is complete and the half-size copies of the As-Builts are made.
7. After the As-Builts have been microfilmed, the Communications and Public Policy Division will submit the As-Builts to the Intermodal Planning Division for their use.
8. Upon completion of their work, the Intermodal Planning Division will periodically return the full-size As-Builts to the District, via truck.

Lighting and Signals - On all roadway lighting and signal projects, a set of "as-builts" will be prepared, pertinent to the wiring alignment, showing the exact location of conduit or cable runs, pull boxes, and any other information which would be beneficial in case of maintenance problems or construction activities in the area. When "as-builts" are submitted to the agency at the time the agency is notified by letter of the acceptance of the installation and to assume the maintenance.

Clearance Letter

The Project Manager shall submit a letter to the Construction Division (with copies to Motor Carrier Permits & Facilities Maintenance) indicating clearance on bridges, sign trusses, and other structures that create a clearance limit.

106.11 OVERRUNS AND UNDERRUNS LETTER

The summary of overruns and underruns letter, which used to be submitted when a contract is finalled, is no longer required. However, NDOT Form 74, Cost Overrun/Underrun Notification is required whenever contract quantities overrun/underrun by \$100,000.00 or more. This letter must go to the Construction Division and the Controller Division so that appropriate redistribution of funds is made as soon as possible. This letter is sent as soon as the change in contract quantities is known. The Controller Division will obtain appropriate approvals.

106.12 CONTRACTOR EVALUATIONS

The intent of the Contractor Evaluation is to report strengths or weaknesses of a contractor's project-related activities, including paperwork, material documentation, attitude, cooperation, and the actual contracted work. It is suggested that remarks be included to substantiate or help explain significantly high or low ratings or other unusual circumstances on the project. The Construction Division maintains a file of the completed forms, reacts to low evaluations, and seeks to improve the performance and project administration of contractors doing work for us.

The project manager should make note of significant events occurring throughout the life of the project to assist in the preparation of the evaluation when the work is complete. In so doing, perhaps problems can be discussed and resolved as they occur. At a minimum, significant problems reported on a contractor's evaluation should be discussed with him or her when the evaluation is presented.

Evaluations are used as a factor in determining the amount of work on which a contractor may bid. Therefore, it is extremely important that contractors are evaluated realistically, factually, and without bias. In this regard, it is equally important that evaluations are completed promptly. To be at all meaningful, data from the EOC's must be current - - and **ALL** of it must be in the system.

The EOC should be completed and submitted to the Construction Division within 30 days of completion of work. For subcontractors, the EOC should be submitted within 30 days of the time you are relatively certain that the subcontractor's work is complete. For a prime contractor, the EOC should be submitted within 30 days of the project completion date established in the District Engineer's letter of tentative acceptance to the contractor. (In other words, the prime contractor's EOC will always be the last EOC to be completed. The performance of all subcontractors reflects on the prime contractor's overall rating, so it is only proper that the prime contractor's overall rating, so it is only proper that the prime's EOC not be completed until the project is entirely complete.)

The Contractor Evaluation is to be completed on every contractor and subcontractor - - except "trucking" subcontracts. (Trucking subcontractors may receive an optional evaluation at the PM's discretion.) SiteManager identifies whether or not a subcontract is for trucking. An evaluation should also be completed on all bridge painting jobs regardless of size.

Contractor evaluations are required for subcontractors at **any** level - - 2nd tier subcontract, for example.

Project Managers shall prepare and sign the evaluation and forward the original to the Construction Office in Lincoln. For projects inspected and managed by consultants, it is appropriate to have the evaluation signed by the local entity's project manager. (The document itself, however, must be prepared on the **RUG** so the results are posted to the database.)

A copy of the complete evaluation must also be furnished to the contractor or subcontractor being rated. Prime contractors deserve to see their ratings as well as those of their subcontractors, so make sure that both get a copy.

All contractor evaluations shall be prepared using the checklist system provided in **RUG**. The use of this system automatically enters the required data into the database. For evaluations of subcontractors, report type of work done by that subcontractor.

Contractor evaluations are required for subcontractors at **any** level, including 2nd tier subcontractors.

The intent of an evaluation is to report strength or weakness of a contractor's project related activities including paperwork, material documentation, attitude, and cooperation. Special attention should be given to contractor ratings of "poor" and "unsatisfactory." Remarks should be included for any individual item(s) that is rated less than fair. Also good remarks should be included when a contractor is given a high rating or deserving recognition.

The Construction Division maintains a file of the completed form, reacts to low evaluations, and seeks to improve contractor project administration. Evaluations are also used as a factor to establish bidder qualifications. Therefore, it is very important that contractors are evaluated realistically, factually, and without bias. The rating system developed is intended to produce a rating of "good" when the minimum acceptable performance requirements are met.

A series of less than satisfactory evaluations may be grounds for disqualifying bidders from further contracts or reducing their bidding qualifications.

It is anticipated that lower than average ratings would have been discussed at a meeting between the Project Manager and contractor representatives prior to form submittal. A contractor should have an opportunity to discuss and understand why a low rating was given. Further, a contractor should be given (if requested) a critique of corrective actions which would prevent reoccurrence of low rating(s).

The RDP Form 344, Evaluation of Contractor, is available on the computer or you can use paper copies.

To provide a broader evaluation of the contractor's performance of their work with reference to their equipment, personnel and prosecution of work, RDP Form 344 "Evaluation of Contractor" has been devised. This report is to be completed by the Project Manager for the prime contractor and subcontractor(s) for each separate time allowance under a contract and submitted with the final computations.

The contract value for the prime contractor shall be the original contract value (not final value). The subcontract value used shall be that authorized by the subcontract approval letter. All subcontract approval letters will show the value of the work being subcontracted.

The working days allowed shall reflect all time extensions approved either by letter from the Construction Division during the progress of the work or by supplemental agreements. If a time extension is forthcoming due to "extra work" a correction in the field entry will be made by the Construction Division. However, extra work should be a consideration taken into account in evaluating the prosecution of the work. When this is the case, an explanation to this effect should be made on the reverse side of the form.

106.13 LETTER OF TRANSMITTAL – FINALED PROJECTS

The Project Manager shall complete a letter of transmittal with project documents when they are forwarded to the District Reviewer. The District Reviewer will also create a letter of transmittal when he/she forwards the records to the Construction Division. The transmittal letter shall include an itemized list of all field notebooks, cross sections, computation sheets, forms, letters, statements, temperature charts, etc., which are being transmitted, so that the shipment can be checked to determine whether it is complete when received. When overhaul or additional haul computations were made in the Lincoln Office, attention should be directed to that fact. If there is any question regarding the accuracy of any of the computations, or there is any item which should be given special attention in the District Office, the items in question should be explained in the letter of transmittal. If the project was completed within the working day time allowance, a working day resume is not required. The transmittal letter should contain a statement indicating whether or not the work was completed within the contract time allowance or any internal time limits. A copy of the Project Manager's transmittal letter shall accompany the project records and final estimate when they are forwarded to the Lincoln Office.

When submitting final records, please label all computation and summary sheets with the item numbers for which documentation is being provided.

106.14 FINALING PROCEDURES

See Construction Division's [Final Review Process Manual](#) for detailed steps to finalize a project.

106.15 UNAUTHORIZED WORK

The contractor should not be permitted to perform work without line and grades established by the Project Manager.

The contractor should not be permitted to perform any work prior to the execution of the contract by the Construction Engineer. The Project Manager can request to be advised by telephone when the contract has been executed, if the contractor is "standing by" awaiting such execution to begin work.

106.16 USE OF ADJACENT LAND UNDER CONTRACT OR LEASE

We no longer require the contractor to provide a release letter. The contractor is responsible to the landowner and the Department will stay out of the agreement unless the Department acquires the access rights.

Option pits obtained by the Department will require a site release. The Project Manager shall contact the landowner and obtain the site release. The release should be obtained as soon as possible while the contractor is still on site with equipment to make corrections.

106.17 FINAL CLEANING UP

The importance of timely cleanup of cast-in-place concrete structures should be discussed at the pre-construction conference. It is the Department's policy to request the contractors to perform the necessary cleanup in flood plains at the earliest possible time to prevent scrap lumber, nails, form ties, etc., from being flushed out on adjacent landowners.

If this material is deposited on adjacent landowners, the contractor must satisfactorily gather and dispose of it before final acceptance of the work involved. It is in the contractor's and the Department's best interests to keep this cleanup work "current".

The District Engineer should be advised if the contractor refuses to perform this work in accordance with this policy and a field book entry made each time the contractor was contacted. Progress payments can be withheld until the area is cleaned.

The contractor shall make a final cleanup of the highway, borrow pits and all ground (off or on the project) occupied by him/her in connection with the work, leaving it in a neat and presentable condition.

106.18 CONSULTANT INSPECTION

In regard to projects utilizing consultant inspection services, some misunderstandings have arisen when our acceptance date preceded a date when the county board "accepted" the project.

Project Development has asked that consultants utilized for engineering and inspection services be given written notice regarding project completion dates. The consultant agreements usually specify the time allowed for the preparation and submittal of As-Built Plans and other final records, and the consultants need to be told when the clock has started. It is my understanding that the consultant agreements state *"The State will provide written notification of construction acceptance to the Consultant."* At least one consultant has reported he does not received the required notice.

Feel free to be somewhat flexible in "starting the clock", but do put it in writing --- and **send a copy of the letter to Project Development** so they may begin the end-of-project paperwork too. The consultant services agreements and payments are audited by the Department, and it is important to have the notification documented.

106.19 PROTEST OF FINAL QUANTITIES OF EARTHWORK ITEMS

If the contractor wants to protest any earthwork item, the contractor must notify the NDOT, in writing, of the disputed quantity, including the approximate quantity that the contractor feels is in error and the basis for the dispute.

The NDOT will review the appropriate data and determine if an error exists and notify the contractor of the decision.

Should the contractor dispute the NDOT decision, the contractor will be allowed to disprove the disputed final earthwork quantity provided the following requirements are met:

1. The work is done under the supervision of and the report is certified and stamped by a registered professional engineer licensed in the State of Nebraska.
2. The contractor furnishes the NDOT Construction Engineer with a cost estimate from the consultant for approval prior to commencement of the work.
3. The contractor furnishes the NDOT Construction Engineer with a copy of the contract with the consultant engaged to perform the work with a detailed description of the procedures and technology to be used in calculating the quantities prior to commencement of the work. The procedures and technology must be compatible with NDOT procedures and technology.
4. The report provided by the contractor to the NDOT Construction Engineer must show all calculations used to determine the quantity, list all data used in the

review and its origin, identify the technology used and identify any differences between the contractor calculations and NDOT calculations.

5. If, after reviewing the report, the NDOT agrees that the final pay quantity or the aggregate correction of all items directly related (i.e.: Excavation and Excavation, Borrow) are in error by more than five percent (5%), the NDOT will compensate the contractor for the quantity in excess of the final pay quantity shown in the final records and for the contractor-incurred expenses to perform the post-construction calculations previously approved by the NDOT Construction Engineer.

Payment will not be made for contractor-incurred expenses to perform the post-construction calculations if the contractor fails to prove that the NDOT final pay quantity is in error by more than five percent (5%).

If the contractor's report indicates that an overpayment of more than five percent (5%) has occurred, the NDOT will pay for the contractor-incurred expenses to perform the post-construction calculations previously approved by the NDOT Construction Engineer and will make payment on the reduced quantity.

6. The issues of waste, shrinkage, compaction and settlement are not eligible for additional payment under this policy, and no allowance will be made for them.

Upon request and at no cost, the NDOT will furnish the contractor with the following information:

1. Preliminary Cross-Sections
2. Slope Stake Data
3. Blue Top Data
4. Design Cross-Sections
5. Current Revisions
6. Standard Plans
7. Design Calculations
8. Current Field Changes
9. Final Cross-Sections

The contractor's failure to fulfill any or all of the requirements stated above will be cause to deny the contractor's claim for additional compensation.

107.00 LANE RENTAL

107.01 INTRODUCTION

Lane Rental is used to minimize the impacts of a project on the traveling public. It is a method of transferring the roadway user costs to the contractor. The contractor must rent a lane in order to close it. This creates a monetary incentive for the contractor to be innovative and minimize the duration of lane closures.

The contractor makes decisions that consider the roadway user costs, both during the bid and as the contract progresses. The contractor's bid consists of a combination of the cost to perform the work (A component) with the cost of the impact to the public (B component) to provide the lowest cost to the public. By providing a more aggressive scheduling package, a contractor may

be able to gain a competitive advantage by decreasing the overall impact to the traveling public and thereby reducing the amount for bid consideration.

1. **Design Phase**

During the design phase, the public impacts of the project are evaluated. The appropriate lane rental units and charges are determined. Lane rental costs will vary depending on the road user impacts, and will be as defined in the special provisions.

2. **Bid Process**

During the bidding process, the contractor determines the number of lane closures that will be required to complete the work. This number is included in the bid proposal.

After bids are opened, the contractor's lane rental bid is combined with the project costs. The project is awarded to the contractor with the lowest adjusted bid.

A lane rental closure is applied anytime a lane is closed. The project personnel tracks lane rentals.

107.02 HOW LANE RENTAL WORKS

1. The contract is awarded based on the lowest responsible bid, using the following formula:

$$\text{The bid amount for evaluation} = A + (B \times \text{LRAR})$$

- a. Bidder's total estimate for all contract bid items (expressed in dollars).
- b. Total number of days subject to lane closure, as defined previously, required to complete all contract work.

LRAR Lane Rental Assessment Rate. These costs can be variable and applied to one or more lanes during a construction project.

This formula is used as a measurement for awarding purposes only, and is not used to determine payment to the contractor. The low bidder for the contract bid items may not be the successful bidder. A bidder who proposes to minimize user impacts realizes the value of that benefit as part of their bid. They also run the greatest risk for damages (overrun of lane rental).

Once the contract is awarded, the number of Lane Rental Working Fund is contractually set. An incentive provision is also included to reward the contractor if the work is completed earlier than the (B) portion bid.

107.03 BACKGROUND INFORMATION

1. The risk in using this type of tool is associated with changes and delays beyond the contractor's control. Changes in lane rental costs will have to be considered with regard to change orders. One way to reduce the chance of problems is to sort out the details of potential third party conflicts prior to construction, to the extent it is possible. These conflicts may involve utilities, railroad agreements, environmental/archaeological issues, hazardous materials, biohazards, public support issues, and other potential problems.

107.04 CONSTRUCTION COST WITH LANE RENTAL

1. Lane rental can increase construction cost. On a standard project, a contractor may see an opportunity to reduce the total impacts. A shorter duration solution may increase the primary item cost but reduce lane rental and overall traffic control costs. The contractor will try to determine the most advantageous bid while balancing the potential overrun in lane rental costs.

107.05 SAFETY ISSUES

1. Safety shall not be compromised. The contractor is required to comply with the approved Work Zone Traffic Control Plans along with other related contract requirements.

107.06 CHANGE ORDERS (ADDED AND DELETED WORK)

1. Change orders need to adjust lane rental days as they would any other contract item that is impacted by the change. Projects that have a likelihood of a large number of changes may not be good candidates for lane rental.

107.07 PRICING LANE RENTAL BY TIME OF DAY

1. The lane rental may be broken out by time of day.

107.08 Lane Rental Charges

1. Lane Rental will be tracked much like working days. Should a contractor go over the bid amount, the Lane Rental will continue to be charged.

DIVISION 200

EARTHWORK INSPECTION CHECKLISTS

DIVISION 200
EARTHWORK INSPECTION CHECKLISTS

200.00 EMBANKMENTS/EXCAVATION CHECKLIST

1. SSHC References: Section 205 Excavation & Embankment
Section 1033 Aggregates
2. Other References: NDOT [Materials Sampling Guide](#)
NDOT [Standard Methods of Tests](#)
3. Inspection Crew: Grade Inspector
4. Inspection Equipment: LWD
Stove/Hot Plate
Speedy Moisture Tester
Thermometer (Surface)
Portable Scale
Metal Thickness Ruler
3 m (10 foot) straightedge
60 lb Sampling Bags
Clear plastic sampling bags
Spade.

200.01 GENERAL COMMENTS

1. The operations of excavating the roadway and borrow material (Roadway Excavation) and the placing, compacting and finishing of the excavation material in the embankments or fills (Embankment) are inspected and controlled as a single "Grading operation".
2. The value of grading may be considerable.
3. "No building is better than its foundation" and good quality embankments and subgrade are essential to the good performance and quality of the base course and pavement structure.
4. The grade inspector's work is of the utmost importance in producing a quality riding surface for the motorist.
5. The large and fast grading equipment employed by grading contractors means inspector should be on site to sample according to the [Materials Sampling Guide](#).
6. The inspector should be thoroughly familiar with *SSHC Section 205 Excavation and Embankment*.
7. Check all contract documents for grading requirements.
8. The type of embankment compaction will be specified in the plans.
9. Construction notes in the plans should be noted and checked against physical features on the project. The right of way should be checked for physical features and obstructions which may not be shown in the plans. Typical items to be checked:
 - a. Check the construction widths needed, and fences which must be moved, and compare them with the available right of way and contracts for additional right of way, borrow and construction easements.

- b. Utility pole lines - check against construction limits and utility agreement provisions.
 - c. Survey or other type monuments or markers - mark or relocate.
 - d. Selective placement notes.
 - e. Trees or shrubs which are indicated in the plans to be preserved - mark as necessary.
 - f. The 2-K sheets (D sheets) contains all of the preliminary and design information of the soils, pit sketches and contracts, preliminary soil compaction curves and soil tests.
10. Rights of adjacent property owners will be protected.
- a. Tile lines and intakes should be located, replaced, and repaired to maintain the integrity of the subsurface drainage. (Preventing unintended drainage from reaching adjacent property.)
 - b. Right of way contracts should be checked for possible special negotiated items which should be included in the work being done.
11. Any contractor operation that causes damage to partially completed or completed work shall be reported to the Project Manager and noted in the Daily Work Report.
12. Make sure the contractor installs silt fences prior to commencing soil disturbing work.
13. Preconstruction Conference
- a. The Project Manager should go over the unusual, difficult, or special items with the grading inspector, and with the contractor.
 - b. Remind the Contractor to call Diggers Hotline of Nebraska, Nebraska 811 for buried utilities, pipe lines, sewers, communication cables, etc. - check for possibility of such not being shown and be sure provisions are made to mark or protect as necessary to prevent damage. Department utilities are not included in the Diggers Hotline locates. Notify the local Maintenance Superintendent for location of state owned utilities.
 - c. Inspection and Control of Grading Operations.
 - d. The contractor's Pre-Watering Plan should be presented and discussed.
 - e. Discuss selective placement requirements.
 - f. Determine what contractor will do to keep stockpiles free from contamination.
 - g. Removal and storage of topsoil materials, shall be discussed.
 - h. Project schedule. (*SSHC Subsection 108.07*)
 - i. Partnering procedures.
 - j. Traffic control.
 - k. Archeological & paleontological discoveries.

- l. Environmental issues(Erosion Control, Wet Lands, Migratory Bird Nesting)
 - m. Detours and Shooflies.
 - n. Railroad Special Provisions.
 - o. Safety issues (Guardrail removal, etc.)
 - p. Material submittals.
- 14. Site preparation such as clearing and grubbing, wetlands preparation, removals, and vegetation disposal on cuts, fills, and borrows are accomplished according to contract documents.
- 15. If stockpiling of selective placement material is necessary, no payment is made for re-excavation. (Topsoil, sand, or any soil identified as select materials.)
- 16. If contract has "Large Tree Removal" count and record trees before work starts.
- 17. Limit the surface area that the contractor may disturb to 18 acres (72,000 m²) plus an equal amount of clearing and grubbing area.
 - a. The Project Manager may increase these limits but only by written notice to the contractor.
 - b. The written notice should include justification for the increase and special procedures the contractor must use to safeguard the environment.
 - c. Copies of this notice must be forwarded to the District Construction Engineer and the District Engineer.
 - d. 87,120 square yards, 18 acres (72,000 m²) is equal to approximately 1 mile (1.6 km) on an average project.
- 18. Check the moisture content of the excavation and borrow material 1-5 days before the contractor starts work.
- 19. Sample and submit borrow material samples to local Branch Lab for optimum moisture, NGI, and Deflection Value.
- 20. Discuss the drying or moistening of the excavated material.
- 21. Check to see if contractor knows the condition of the soil.
- 22. Verify how the contractor will control moisture in Class "III" embankments
- 23. Contractor should mix clay/non-granular material to uniformly distribute the moisture and various soil types before compaction.
- 24. Pre-Watering can be wasteful. Ponding or sprinkling may require more water and more work than wetting the soil as it is placed.
 - a. But the moisture content will be more uniform and dust will be eliminated.
 - b. The contractor is responsible to obtain the soil samples both before and during the water application.
 - c. The Project Manager will run moisture tests to determine water application rates and to check the progress of the penetration. Compare the amount of prewater to the expected amount that would be required if added at time soil is placed.

- d. The following example does not allow for water lost by evaporation, runoff, etc., and will need to be supplemented by information derived from subsequent testing.
 - e. As a precautionary measure against overwatering, leave some dry material for mixing with soil which was over watered. (Required water per cubic meter) (cubic yard) - (Natural in place water in the soil per cubic meter) (cubic yard) = Amount of water to add or if negative result, the amount of water to remove per cubic meter (cubic yard).
 - f. Preserve the natural vegetation on the area until the watering is complete.
 - g. If the vegetation is removed before watering, or the soil type, slope, or condition warrants, the ground should be ripped 2 feet (650 mm) deep on its contours approximately 4 feet (1.2 m) centers to allow penetration of water and minimize runoff.
 - h. Adjust the application rate to control runoff and erosion.
 - i. Construct dikes to control runoff and erosion.
 - j. Document any wasted water in field book.
25. Excavation areas should be disced immediately after pre-watering to reduce evaporation.
- a. A two to three week curing period is necessary to permit the water to move downward and become uniformly distributed in the soil.
 - b. The importance and length of this curing period will vary with the soil type and conditions of the soil. (Clay very important--sand not important.)
26. Compacting equipment which produces a glossy surface shall not be allowed. This may cause lamination.
27. PM should be notified and review all haul routes over structures.
28. Know the moisture, deflection/density requirements for each section of the project.
- a. Review *SSHC Subsection 205.03* for construction methods and procedures which give moisture, deflection/density, and lift thickness requirements.
29. A good practice is for the contractor to spread the soil as thinly and smoothly as practicable, to distribute the hauling equipment over the embankment to minimize the rolling.
- a. Discing is required to get uniform density.
 - b. Layers must be compacted before the next layer is placed.
30. Require rolling over entire area--completely to the outside edges.
31. Require that hauling and leveling equipment is routed over the full width of the embankment.

32. Visually check the subgrade and the embankment under compacting equipment.
 - a. Generally, when a sheepsfoot walks out of soil, it is a good indication of proper compaction and ready for testing.
 - b. Silty clays may show movement/instability and yet be at specified density. (When this occurs, additional work is necessary to stabilize the fill.)
33. Compare earthwork to the stakes--tell the Project Manager and the contractor if something does not look right. Make sure stakes are uniform and easily read.
34. Perform a control strip on unknown materials without compaction curves and submit sample to Branch Lab.
35. Insist that all objectionable material such as logs, vegetation, trash, or unsuitable soils are removed before fill is started.
36. Require old pavements to be removed if embankment will not be greater than 3 feet (1 m). If more than 3 feet (1 m) of embankment the pavement must be broken-up. *SSHC Subsection 104.05* defines "minor obstruction" and lists examples of when the contractor should be paid extra for removal of unforeseen obstructions.
37. The roadbed will be adequately drained and protected at all times. (Poor drainage during construction often results in an inferior construction.)
 - a. The roadbed should be tight (shaped, bladed smooth, and rolled, so as to shed water) at the end of each day.
 - b. Flowable fill, granular fill, drain pipes, or other requirements may be necessary to permanently correct the problem.
38. Settlement or side slip may result in slope failures or side hills if not properly stepped or plowed.
39. Settlement may result at Grade points (0-0 sections) due to fill taper, improper or insufficient compaction and different soil type (Subsoil - topsoil - parent soil) meeting. Particular attention should be given to the compaction of the new embankment at 0-0 points. Usually blending to 3 feet (1 m) depth is required.
40. Settlement of areas adjacent to or over structures frequently occurs. Take additional moisture and deflection readings in these areas.
 - a. Proper placement and compaction of material in the areas inaccessible to rollers and the earth moving equipment will eliminate this problem.
 - b. This involves close contact inspection of compaction performed by small mechanical tampers, which is tiresome, manual work.
 - c. The inspectors' must confirm that this work is properly performed.
 - d. When the slope is greater than 1-vertical to 4-horizontal, step the ground to prevent wedging action against the structure.
 - e. Use selected soil which will compact readily, if available.
 - f. Silty soil should not be used.
 - g. During backfill operations, displacement of wing or abutment walls may be checked by erecting a "telltale" before backfilling is started and checking the wall for movement as the backfill progresses. If movement is

- detected, backfill operations should be suspended and the Project Manager advised of the problem.
41. Watch for and report unstable and unanticipated settlement to the Project Manager and Geotechnical Engineer.
 - a. Bulging at the toe of the slope.
 - b. Cracks running parallel to centerline are indicators of unstable embankment conditions.
 - c. Subsidence at bridge ends, excessive cracking inside box culverts or unanticipated swales are signs of excessive settlement.
 - d. Pumping action.
 42. Where surcharges are included in the plans as work to be accomplished during construction, the Geotechnical Engineer of the Materials and Research Division wishes to be informed before the beginning of the construction of the surcharge. Construction progress and anticipated paving date may allow a change in the height of the surcharge necessary to complete the anticipated settlement.
 43. Confirm culvert backfill material meets specification requirements. Backfills on box and pipe culverts should be brought up evenly on both sides at the same time to avoid displacement of the structure.
 44. When tamping under the lowest 90° of a culvert place elevation check stakes at the ends of the pipe to detect any rise.
 45. The grade inspector should be alert to possible damage to any drainage structures which the contractor's heavy equipment may cause by crossing or working over such structures, and particularly to possible damage to pipe culverts covered with minimum fill. The contractor shall be informed immediately of any observed damage and the information recorded in the field book.
 46. Large shortages or overages of excavation material may be encountered.
 - a. Revising the grade lines, rebalancing, or obtaining additional material outside construction limits or balance points require prior District approval.
 - b. The Project Manager should be contacted on all overage or shortage conditions.
 47. The grade inspector should inspect and advise the Contractor of deviations from the lines and grades as staked by the Project Manager.
 48. Finish grading
 - a. The roadbed surface should be finished within 5/8 inch (15 mm) of the finish grade stakes.
 - b. The shoulder lines and slopes should be reasonably true.
 - c. Side ditches and borrow areas should be finished reasonably true to grade and should drain.
 - d. Finish grade stakes should be set for finishing flow line grades in borrow pits if the width and grade are such that stakes are essential to finishing the pit to provide proper drainage without ponding.

- e. Finish grading must be completed on a timely basis so that erosion control measures may progress satisfactorily.
49. All finished work and any other areas that need erosion control should be kept current with covercrop seeding or other BMP's according to the SWPPP performed as the work progresses.
50. Any repair required on a section that has been tentatively accepted will be paid as extra work (unless considered to be the fault of the contractor). (*SSHC Subsections 105.13, 107.14 and 109.08* define tentative acceptance.)
51. The inspector should require the contractor to move the field lab as necessary to facilitate the field testing.
52. The minimum number of tests necessary to verify that the compacted embankment meets the specified requirements for moisture and deflection will be shown in the [Materials Sampling Guide](#). The grade inspector will test soil samples for two primary purposes.
- a. To monitor the effectiveness of the contractor's operations and use of forces and equipment in controlling the moisture and the compaction of the soil. These are called "job control tests".
 - b. To verify that the completed work (compacted embankment) meets the requirements for moisture (if specified) and density. These are called "acceptance tests".
53. The number of moisture-deflection tests will vary but the minimum is spelled out in the [Materials Sampling Guide](#). However, the inspector is encouraged to take additional tests as are necessary because with the LWD, moisture and deflection are easily monitored. "Job control tests" which indicate the need for additional work to meet moisture-deflection requirements shall not be counted in the "acceptance tests" since a check test would be required in the area represented by the original sample.
54. Daily work report, shall include:
- a. Date, weather, soil conditions.
 - b. Information on contractor's forces include numbers of personnel, numbers, types, and sizes of equipment, hours worked each day.
 - c. Data on work in progress include section of the project, balance limit, channels, dikes, rough grading or finish grading, etc. This should include a record of known construction balance points, particularly balance points between "off-site" borrow pits.
 - d. Weather conditions or other conditions affecting the progress of or delaying prosecution of the work, equipment break downs, etc.
 - e. Sufficient records of the progress of the work, to enable the Project Manager to prepare progress reports, working day reports and progress estimates accurately.
 - f. Estimates of wasted water, and cause.
 - g. Disputes.

- h. Contractor's progress should be monitored to check that the work is being completed according to the construction schedule. Report major deviations.
55. Pay Item Documentation
- a. Any supporting information or records necessary to facilitate the preparation of the required reports on sampling and testing.
 - b. Calibration of distributor water tanks and of meter accuracy if the water is metered.
 - c. Daily record of water hauled (on large projects the water applied may be kept in a separate "water application notebook"). Include location (i.e., station of the excavation, borrow pit, embankment or surface) where water was applied and obtained.
 - d. Select placement, confirming information, etc.
 - e. Identify all work performed on the project by the contractor and subcontractor actually completing each pay item.
 - f. Make entries supporting extra work quantities.
 - g. Get the contractor representative signature agreeing to pay quantities in the entry.
56. Method of Measurement
- a. See CM Section 1300 for instructions to take cross sections. (Use Geopak when possible.)
 - b. Measure and pay authorized excavation of material below grade and overbreakage or slides.
 - c. Unsuitable material which is removed below grade in excavation areas, or below existing ground in embankment areas, is considered to be "authorized excavation of material below grade".
 - d. If the existing ground in an embankment area must be dried to such a depth as to be impractical to dry in place, the contractor may be ordered to undercut (excavate below grade) and haul this material to higher areas, drying and using it in the construction of embankment.
 - e. The volume of the undercut would also be considered to be authorized excavation below grade, and the volume measured and paid.
 - f. Larger quantity under cuts should be authorized by the District Construction Engineer and the volume should be measured by cross sections. Tell the Contractor what is "larger" at the preconstruction conference.
57. Water, Applied
- a. Distributor truck tanks may be calibrated by determining the mass of both the empty and filled truck. The net mass (kg) (lb) is the tank capacity, in liters (gallons).
 - b. Each truck tank should be numbered and the numbers and capacities recorded in the water haul notebook.

- c. Calibration of meters for the pre-watering methods may be accomplished by pumping through the meter into a water truck and checking the mass of water against the liters on the meter.
- d. Meters may be calibrated by registered pump and meter service companies and their calibrations may be used if they are current. Calibrations are good for one year.
- e. Trucks that are too large to measure their mass on available commercial scales may be calibrated from capacity if model numbers, serial numbers, etc., are the same as shown on the specifications literature.
- f. If the water is measured by tank count, the grade inspector will record each day, the number and size of loads delivered to the project by each truck.
- g. If the quantity of water is measured by a meter, the grade inspector will record the meter readings at the beginning or ending of each day or shift.

58. Calibration

- a. Water meter calibration sheets usually show a correction factor to be used to convert meter volume to actual volume for differing rates of delivery.
- b. The rate of delivery for the application can be determined by timing the meter and computing the gallons (liters) per minute being delivered.
- c. The gallons (liters) per minute delivered will vary with the length of pipe and number of sprinkler heads being used.
- d. Therefore, the delivery rate should be determined and documented for each pipe setup so the correction factor can be determined and used.

59. Wasted Water

- a. The quantities of water wasted or not eligible for payment should be entered in the records each day with substantiating or estimating information to support the quantity deducted or ineligible for payment.
- b. The contractor should be furnished the documented quantities of water wasted each day, to facilitate resolving of any discrepancies in quantities.
- c. The grade inspector is responsible for the proper determination of the quantities of water measured for payment, and each day's entry in the notebook should be validated by their signature and agreed to by the contractor and signed.

60. Metering is more practical and economical than a tank measurement.

- a. Encourage the contractor to provide an acceptable meter at the point of loading the trucks to measure the water for payment.
- b. If the water is being applied by the truck sprinkler method, the "Water Applied Haul Sheet" (NDOT Form 8) may be prepared by the truck driver, and used by the grade inspector to determine the distribution of water applied on various sections of the project, finishing, etc., and for cross-checking quantities.

- c. These sheets are to be used for this purpose only and not for payment, and should not be submitted with the final records.

200.02 CRITICAL CONSTRUCTION REQUIREMENTS

- 1. Preconstruction Conference.
- 2. Verify how the contractor will control moisture in Class III" embankments.
- 3. Visually check subgrade and embankment under compacting equipment.
- 4. Stability and Settlement Indications. Watch for and report to the Project Manager and Geotechnical Engineer indications of instability.
 - a. Bulging at the toe of the slope.
 - b. Cracks running parallel to centerline are indicators of unstable embankment conditions.
 - c. Subsidence at bridge ends, excessive cracking inside box culverts or unanticipated swales are signs of excessive settlement.
 - d. Pumping action.
- 5. The roadbed will be adequately drained and protected at all times. Roadbed should be bladed smooth and rolled tight at the end of each day.
- 6. All contract pay items will be properly documented.

200.03 SAFETY AREAS:

- 1. Maintained Traffic
 - a. Contractor's vehicles must adhere to project traffic control procedures.
 - b. Flaggers must be certified and use proper procedures.
- 2. The contractor should be told to stop all unsafe activities such as:
 - a. Speeding trucks and other equipment.
 - b. Inoperable back-up alarms.
 - c. Inoperable or nonfunctional strobe lights.
- 3. Contractor vehicles shall be parked beyond the lateral obstacle clearance.
- 4. Worker protection barriers should be placed as shown in the plans.
- 5. Traffic markings should clearly indicate traffic flow.

200.04 NDOT TESTS:

- 1. NDOT T2835 Light Weight Deflection (LWD) test method
- 2. NDOT T 99 Soil Density (See Earthwork)
- 3. Soil Type AASHTO T89 & N90
- 4. NDOT T 2 Sampling Aggregate from Stockpiles
- 5. Moisture: AASHTO T 265.

200.05 SAMPLING REQUIREMENT/FREQ.:

- 1. See [Materials Sampling Guide](#)

200.06 INSPECTOR'S RECORDS & FORMS

1. Daily Work Report
2. Water application notebook
3. Field book
4. NDOT Form 8, Water Applied Haul Sheet
5. Weekly Report of Moisture and Deflection

<http://dot.nebraska.gov/media/6369/ndormoistureanddeflectionform.xlsx>

200.07 NDOT POINT OF CONTACT

1. Materials & Research Geotechnical Engineer

201.00 GENERAL GRADING INSTRUCTIONS

1. Grading Inspection
 - a. A grading inspector should devote the majority of their time to observing and checking the contractor's excavating, drying, moistening, spreading and compacting operations, and securing samples, vary the balance of their time in testing samples and making neat and accurate records. The grade inspector will need to check moisture (if control is required) and stiffness at the rate shown in the [Materials Sampling Guide](#) (usually check moisture and stiffness once for each 1,500 cubic yards placed and once for each 1,500 square yards of shoulder or subgrade).
2. Equipment
 - a. Equipment should be sufficient to meet compaction requirements and the type of equipment used should be recorded in the DWR.
3. Overweight Axle Loads
 - a. All oversize hauling units delivering equipment or materials to the project shall be legal loads and/or have appropriate hauling permits issued by the Motor Carrier Permit Office. The State Patrol Carrier Enforcement Division has enforcement authority outside of the project limits and on those portions of the construction project maintained to through traffic. Overweight and tracked loads on bridges inside the construction limits, need to submit a Special Construction Vehicle Permit Request to the Structures and Grading Section Head in the Construction Division.
4. Hauling On or Over Surfaced Roads
 - a. The contractor must protect from damage all public roads that will be used by the contractor. Usually berms (greater than 300 mm (12 inches) thick) are constructed over the road surface for the earth moving equipment to use.
 - b. Certified flaggers are required when the berm is on an active road.
 - c. The berm must be removed from the road and shoulders at the end of each day when the road is active and the surface area cleaned.
 - d. The berm must be maintained constantly by the contractor. This will allow safe traffic flow over the berm.

5. Blue Tops
 - a. After the roadway excavation and roadway embankment has been constructed substantially to grade elevations, the construction survey party will set finish grade stakes for finishing the grade or subgrade to the lines and grades shown in the plans. The blue top book elevations must be checked to insure they conform to the information shown on the plan cross-sections.
6. Rounding of Hinge Points
 - a. The Department has determined that the rounding of “hinge points” in the cross-sectional elements can significantly reduce their potential as hazards. Rounded slopes reduce the chances of an errant vehicle becoming airborne, reduce the hazards of encroachment, and afford drivers more control over their vehicles.
 - b. The Construction Division suggests that finish grading and ground preparation activities that result in the rounding of hinge points be permitted, if not encouraged. For example, an 8 foot disc that “hangs over” a 6 foot shoulder will provide the desired effect and should not be ruled unacceptable. However, this suggestion is not meant to imply that the cuts and embankments may be built to other than the cross-sections shown in the plans.
7. Erosion Control
 - a. The contractor must have a SWPPP and follow it before any grading is allowed.
8. Unmarked Human Burial Sites
 - a. The contractor shall comply with the Nebraska Unmarked Human Burial Sites and Skeletal Remains Protection Act, Sections 12-1 –12-1212. If human skeletal remains or burial goods associated with an unmarked human burial in the ground or on the ground are discovered, then all work in the immediate area of the discovery shall stop and the contractor shall contact the NDOT District Environmental Coordinator. The NDOT District Environmental Coordinator will then comply with Section 12-1205, notification of local law enforcement in the county in which the remains or burial goods are found. The NDOT District Environmental Coordinator will promptly consult with the appropriate federal, state, and tribal agencies to determine if further field investigations are required before maintenance operations may resume. Pertinent legal authorities covering such discoveries include: the National Historic Preservation Act, the Native American Graves Protection and Repatriation Act, the Archeological Resources Protection Act, the Nebraska Unmarked Burial Sites and Skeletal Remains Protection Act, and the Nebraska Archeological Resources Protection Act.
 - b. Any discovered archeological or paleontological objects or deposits are not the property of the Contractor. The NDOT Environmental Coordinator will consult with appropriate federal, state, or tribal agencies to determine the proper disposition of such remains.

CULVERT STAKES

Offset

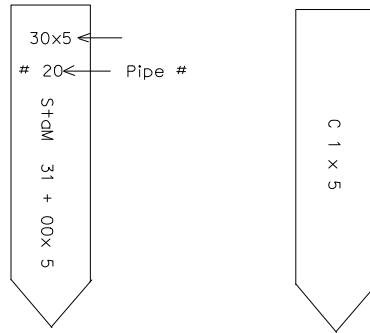

ROW STAKES

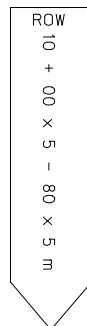

Green-yellow flag for easements

Orange flag ROW

202.00 CLEARING AND GRUBBING

202.01 DESCRIPTION

1. This item has a lump sum contract price for the entire right of way and easement area. At each estimate period, the Project Manager shall pay a percentage of the contract price based on the estimated percent complete. The areas for each estimate should be shown on a set of plan-profile sheets and should be blocked out or otherwise noted so that each estimate area can be determined. When changes in location, R.O.W. widths, or easement areas result in changes in areas from those shown on the plans, the extra area would be handled as extra work.

202.02 CONSTRUCTION METHODS

1. The clearing and grubbing operation, although shown as one pay item, actually involves two separate operations. By clearing it is meant the removal of trees, brush, and shrubs from within the limits of a designated area. Grubbing usually refers to the removal of all projecting roots, stumps and similar obstacles within the construction limits. Removal should be to a depth of at least one foot below the existing ground surface in fills.
2. The importance of properly clearing and grubbing a project cannot be over emphasized. Some failures that we encounter in our roads can be traced to an area that has been improperly cleared and grubbed. It must be pointed out that the success in building a road begins with the clearing and grubbing operations. It is essential therefore that inspection personnel assigned to this work be informed and so instructed as to the seriousness of the work. They should remain alert for conditions, which will result in any future maintenance problems. Stumps or logs left in the subgrade can cause failures in the roadway.
3. The Project Manager, inspector and the contractor's designated superintendent should field check the project together. They should discuss and agree on the method of stake out control. The contractor's superintendent will be made aware of any special conditions in the right of way agreements, special provisions and plans. The superintendent should be advised of the method of marking trees and shrubs that are to remain outside the construction limits.
4. Prior to beginning clearing and grubbing operations, the limits of the clearing must be established by the Project Engineer. Normally, these limits involve the total area inside the limits of construction.
5. The contractor shall abide by appropriate fire codes of local governments having jurisdiction over the area and secure any required permit.
6. In lieu of open burning the contractor's plan for disposal of clearing and grubbing rubbish may include the disposing of materials outside the right of way limits. The contractor may dispose of this rubbish in a landfill approved for fill materials of this type or on private property. In the case of the latter, the contractor must obtain written permission from the property owner. However, written permission of the property owner does not necessarily automatically provide approval by the Department. Prior to approval of such disposal areas by the Department, the Project Manager should assure that the contractor's plan of disposal includes the following:

- a. Disposal area is not in a location to present an unsightly appearance to the project.
 - b. Satisfactory method of treatment of the area for appearance and erosion control is specified in the plan.
 - c. Disposal area will not present future maintenance problems for the Department.
 - d. Approved waste site permit.
7. Grubbing outside actual foundation excavation limits at bridge sites and channel changes should not be performed in most cases. Stumps, which aid in erosion control, should be left in place provided they will not act as debris (drift) catchers.
8. Any trees previously designated to remain and are damaged by the Contractor should be repaired or replaced at no additional cost. All cut or scarred surfaces of trees and shrubs should be treated.
9. The Contractor shall not expose more than 18 acres of erodible material without prior approval of the Engineer. Consideration for an increase in the specific limit may be given upon written request and presentation of an acceptable justification for such an increase.
10. Various areas should be cleared and grubbed to the extent that topsoil stripped from them will not contain stumps or roots that cannot be used at a later date. Cut and fill areas often will be stripped and the stripping stockpiled for use as topsoil. The Contractor should not be permitted to strip these areas until the clearing and grubbing operation is complete. The inspector should notify the Project Manager when an increment of the right of way is satisfactorily cleared and grubbed. The Contractor should not be permitted to begin grading until approval by the Project Manager of the cleared and grubbed increment is given.
11. During the inspection of clearing and grubbing operations is an excellent time to make observations and a record by station number of areas which appear to be unusually soft, spongy, contain other evidence of unsatisfactory material, seeps or other conditions which may require corrective measures.
12. The following checklist for clearing and grubbing will be useful to the inspector:
- a. Study specifications, standard plans and special provisions
 - b. Is clearing and grubbing being performed within required limits?
 - c. Is timber being disposed of in accordance with plan and specification requirements?
 - d. Is the contractor keeping an up-to-date record of the amount of exposed erodible area as grubbing is performed?
 - e. Has the inspector discussed necessary erosion control measures with the Project Manager and contractor's personnel? (See that these erosion control items are promptly installed.)
 - f. Is the inspector alert for the necessity of additional erosion control measures? Have these been discussed with the Project Manager?
 - g. Is selective clearing being done within normal clearing limits?

- h. If burning is performed, are the specifications being followed? Has Contractor obtained permits as required?
- i. Is debris being disposed of outside of the right of way? Is this disposal area out of sight of the right of way? Does the Contractor have proper authority for this disposal area from the property owner and the Project Manager? Has Contractor submitted and received approval of their plan for disposal on clearing debris and rubbish? Has all clearances and /or permits been obtained?
- j. Has inspector notified the Project Engineer when an increment of the right of way has been properly cleared and grubbed? Has an "on foot" inspection of the increment been made?
- k. Has the Project Engineer been advised of possible soft or spongy materials, seeps or other unsatisfactory materials?
- l. Does the inspector's diary show weather conditions, location where clearing and grubbing is being done each day, the size of the crew, the equipment being used and other special comments?
- m. The areas cleared and grubbed each month should be shown on a plan sheet indicating the estimate number on which it was paid.

202.03 METHOD OF MEASUREMENT

- 1. The Clearing and Grubbing inspector should keep a daily inspector's report. This report should include weather conditions, locations of clearing and grubbing by stations, contractor's labor and equipment and pertinent comments and instructions to the Contractor concerning the work.

202.04 BASIS OF PAYMENT

- 1. There may be considerable elapsed time between an estimate of clearing and grubbing and the actual work. If actual site conditions are different than those shown in the contract documents, the following suggested resolutions are provided:
 - a. If the pay item is "General Clearing and Grubbing" then no action is necessary because tree removal is subsidiary for trees with circumference of 80 inches or less at 40 inches above ground level.
 - b. If the pay item is "Large Tree Removal" then a new tree count should be taken and recorded before the contractor starts work.
 - c. If a tree has been cut, leaving branches and the stump, payment is covered under "Clearing and Grubbing" or "Large Tree Removal." If the stumps is the only item remaining and payment method is large tree removal, you would count just the stump as a tree.
 - d. If a fence is partially removed or in poor condition but requires an identifiable removal operation, full price for fence removal may be made.
 - e. Where brush or junk has recently (After the letting was announced) been deposited within the right-of-way, a price agreeable to both the contractor and the Project Manager may be negotiated or a force account extra work order may be used.

203.00 REMOVAL OF STRUCTURES AND OBSTRUCTIONS

203.01 DESCRIPTION

1. This work consists of clearing, removal and disposal of all obstructions not designated to remain on all tracts. All Federal, State and Local laws shall be followed including environmental concerns regarding lead plates, asbestos or other hazardous material.

203.02 CONSTRUCTION METHODS

1. Before this work is begun the Inspector should check the plans carefully to determine the items or locations where materials are to be removed and salvaged. Locations where portions of structures are to be retained and extended should be noted. These locations should be checked with the Contractor so that there will be no misunderstanding as to where salvage or the partial retention of structures will be required. Salvage will not be required unless so indicated on the plans. For miscellaneous facilities, normally the only items marked for salvage will be pipe culverts, guardrail and guardrail items. Bridge structures planned for salvage, depending on the type and condition, will generally be indicated on the plans.
2. Where salvage is required or a part of a structure is to be retained, the Inspector should be on the site during the salvage operations to make sure that proper care is being used in salvaging. Salvaged materials may be designated for storage on the right of way to be picked up by State Forces at a later date, designated for transporting by the Contractor to a designated State Storage Yard or designated for reuse on the project in progress.
3. Before beginning any removal that would interfere with traffic, provisions must be made to properly handle traffic through the work site. The Engineer should insure that this has been done before permitting the Contractor to begin any work, which would otherwise cause interference with traffic. If the Contractor places broken concrete or other suitable waste material from removal operations into a fill area, the material should be carefully spread in layers and with pieces far enough apart that no voids will be left. The Inspector must not permit porous areas surrounded by non-porous material that would trap water. If it is desired that broken concrete be stored for later use as rip rap, etc., the Contractor should be directed where to store this material. Any such material used later will be paid for again under the pay item for which it is used unless shown otherwise on the plans or in the proposal.
4. The reasons for removal of miscellaneous existing facilities would include:
 - a. Conflicts with construction features of the project in progress,
 - b. Insufficient strength to support higher embankments, etc.
5. The material excavated in removing the structure must be replaced and compacted as directed as a part of the work included in the unit price for removal of structure. Additional backfill material needed to bring the backfill up to the specified level will be paid for at the unit price of the material used. Where designated on the plans or in the proposal to be salvaged, all sound materials having salvage value shall be carefully removed without undue splitting or breakage and all bolts, nails, etc.; shall be removed there from. The use of equipment or facilities, which might damage members or portions of the structure

- to be salvaged will not be permitted. Any damage to material to be salvaged should be recorded in the inspector's daily report.
6. No salvaged material shall be used in the construction of the new work, except where so provided on the plans or in the proposal. The Contractor shall not make temporary use of any materials or parts from old structures without the written permission of the Engineer. Any materials and parts so used shall be left at a designated point at the same site and in substantially the same condition in which they were when removed from the old structure.
 7. Structural steel, timber or other salvable material removed from old structures, unless otherwise specified or directed, shall be stored in a neat and presentable manner on blocking at designated locations within the right of way. Structures or portions thereof which are specified on the plans or in the proposal to be salvaged for re-erection shall be stored in separate piles.
 8. Salvaged bridge materials such as steel superstructures and frames, unless otherwise provided, shall be match-marked and dismantled in an approved workmanlike manner and removed carefully so as to avoid damage. Guardrail designated for salvage shall be carefully dismantled in condition for re-erection and rail, cable, hardware and posts stored as directed at accessible points for removal. Cable shall be rolled or spooled in suitable condition for hauling.
 9. When the plans or proposal do not provide for the salvaging of material from existing roadway or bridge structures designated for removal, all materials from such become the property of the Contractor. These materials may be removed or disposed of by methods of their selection provided such does not conflict with other requirements of the specifications or will damage any existing work or facilities to be incorporated into the work.
 10. If no direct pay items are provided for the removal of certain items, removal of such items will be a subsidiary obligation of the other items of work, with the exception of unforeseen items as described in Subsection 104.05.
 11. In some cases complete removal of the structure may not be required if it can be properly broken up in-place and all voids properly filled. Prior to allowing this method of removal, the Engineer should assure himself/herself that the material left in-place would not interfere with bridge piling, drainage structures, utilities or any other construction feature to be installed. Measurements of items removed should be made daily by the Engineer and recorded in the daily inspector's report or appropriate field book.
 12. Removal and Disposal of Old Pavement
 - a. Pavement is to be removed from all cuts and fills with less than 3 feet (1 m) of cover. The removed concrete is to be broken into pieces with an area of 2 square feet (0.2 m²) or less if placed in fills. (*SSHC Section 203*)
 - b. Where existing PCC pavement would be located more than 3 feet (1 m) under the proposed profile grade, the PCC pavement will be required to be broken into surface areas that will not exceed 4 square feet (0.4 m²) when left in place. If the existing pavement has been resurfaced, the asphalt resurfacing will be removed if the PCC pavement is to be used as slope protection or in a waterway. (*SSHC Subsection 205.03*)

13. Disposal of Asphaltic Concrete Pavement
 - a. The contractor shall manage the material in accordance with all current federal and state rules and regulations.
(SSHC Subsection 107.01)
 - b. Salvaged asphaltic cement concrete pavement may be used as special backfill material. When intended for special backfill material, the ACC pavement is normally removed by scarification. Removed bituminous materials may be placed in the outer slopes of embankments, 12 inches (300 mm) below the finished shoulders and foreslopes. (See *SSHC Subsection 205.03*)
14. Hazardous Material (Wells, Asbestos Fibers in ACC, Building Removal, Underground Storage Tanks, Archeological Remains)
 - a. Hazardous materials that are known will be identified in the plans. Appropriate federal, state and local regulations must be followed. Unexpected hazardous materials that are encountered in the field should be handled according to the Unexpected Hazardous Waste Plan. (See [Unexpected Hazardous Waste Plan](#)).

203.03 METHOD OF MEASUREMENT

1. All items shall be field measured as shown in the current specifications.

203.04 BASIS OF PAYMENT

1. All items shall be paid as shown in the current specifications.

204.00 TEMPORARY WATER POLLUTION CONTROL

204.01 DESCRIPTION

1. This section addresses activities to prevent water pollution from soil erosion. This is covered in more depth along with various other types of pollution and permit requirements in Division 1100.

204.02 LIMITATION OF OPERATIONS

1. The contractor should limit grading operations to the area required. Permission is needed if this area is to exceed 18 acres. Permission is granted based on the Contractor's operations and ability to properly maintain the area.

204.03 CONSTRUCTION METHODS

1. The contractor shall plan and construct the project to avoid erosion, install permanent erosion control in a timely manner and provide temporary erosion control as required.

204.04 METHOD OF MEASUREMENT

1. "Temporary Water Pollution Control" is not measured for payment. However, individual items used to complete the work will be measured according to their appropriate units.

204.05 BASIS OF PAYMENT

1. No direct payment is made for "Temporary Water Pollution Control". However, payment for individual temporary erosion control items needed to complete the work will be paid as plan items or additional items added as necessary.

205.00 EXCAVATION AND EMBANKMENT

205.01 DESCRIPTION

1. The importance of being able to identify soil types cannot be overemphasized. Some soil types have to be placed in the proper location. The inspector must be sure that the work is performed according to the plans.
2. The balance factor is the change in quantity from cut to fill and includes subsidence, change from borrow density to the final compacted density, incidental loss, and all other factors changing density.

205.02 MATERIAL REQUIREMENTS

1. There are four basic categories of earthwork.
 - a. Excavation
 - ◆ Final cross sections determine pay quantity.
 - ◆ This item covers the excavation on the project ROW.
 - b. Excavation (Established Quantity)
 - ◆ Payment is based on the plan quantities.
 - ◆ This item covers the excavation on the project ROW.
 - c. Excavation Borrow
 - ◆ Final cross sections determine pay quantities.
 - ◆ Borrow will be needed from off-site source(s).
 - d. Earthwork-Measured-in-Embankment
 - ◆ Plan quantities of the proposed embankment are used to determine the payment quantity.
 - ◆ Contractor must forecast shrinkage. (A change from borrow density to compacted density.)
 - ◆ Borrow from off-site sources.
2. "Excavation" and "Excavation Borrow" are paid based on final cross sections. The Project Manager may forego the final cross sections when the contractor agrees, in writing, that the plan quantities, including field adjustments and revisions, accurately reflect the work done. Payment will be made under the original contract items. Do not eliminate the original contract item and establish a new "E. Q." item. However, a change order to void and supersede SSHC Subsection 205.04, Method of Measurement, will be required. The Revision should read as follows:
 - a. The "Excavation" is the plan quantity in cubic yards (cubic meters). "Excavation" is not field measured.

- b. The "Excavation Borrow" is the plan quantity in cubic yards (cubic meters). "Excavation Borrow" is not field measured.
- c. The Project Manager and the contractor may elect to measure areas in question and accept the remaining areas as "Established Quantities."

3. Unsuitable Material

- a. There are some instances that the soil should not be allowed in the roadway. These may include excessive amounts of organics such as plant material, wood, or other materials that could break down; rubble such as concrete, brick, asphalt or other debris that may need to be disposed of in other manners.
- b. In low-lying areas and in wet soil contact zones, it may be necessary to declare most of the material as unsuitable at the direction of the Project Manager if it is determined that the material cannot be dried in place by discing. A granular material that will drain can be used to replace the wet soil. An effort should be made to provide an outlet for water which may occur in the embankment or subgrade. Most wet soils that are removed can be dried and reused in some other area.
- c. Soft shale, in some cases, can be moved in a manner similar to soil excavation. Shale cuts are usually benched and covered with topsoil in accordance with the plans. If unexpected shale is found, contact the Materials and Research Geotechnical Engineer. Slides can occur in backslopes of shale cuts, and flatter slopes may be required.

4. Rock Material

- a. If material to be excavated is too tough to be ripped, the Project Manager, contractor and a geotechnical specialist experienced in blasting should discuss the aspects of the work to be done.

5. Frozen Material

- a. Thick Frozen Layers:
 - (i) If material to be excavated is frozen, the frozen layer shall be removed prior to excavation. Frozen material removed may be used after it has thawed provided it is still suitable. No additional payment will be made for removing or re-handling the frozen material. See Subsection 205.02
- b. Thin Frozen Layers:
 - (i) Thin layers may be left in place if it can be broken and scarified into the existing layers. See Subsection 205.02

6. Contractor Furnished Borrow Areas

- a. On some projects, the contract documents will require a "contractor borrow." In these cases, the contractor is responsible for submitting a site approval request to the Construction Division (allow at least 60 calendar days for the Construction Division to obtain site approval from Nebraska agencies).

Construction Engineer
Nebraska Department of Transportation
1500 Highway 2
P.O. Box 94759
Lincoln, Nebraska 68509-4759
Fax No. (402) 479-3598
Check website and link with information

- b. The Contractor will obtain soil samples to verify material is acceptable. The Project Manager will forward the samples to the Materials & Research or Branch Lab for evaluation. (See *SSHC Subsection 205.02.*)

205.03 CONSTRUCTION METHODS

1. Embankment Construction

- a. The construction of embankments is covered in *SSHC Section 205*. This Subsection provides a more detailed picture of certain procedures mentioned in the *Specifications*. These comments should be regarded as explanatory but in no way supersede or invalidate Specification requirements.

2. Site Preparation

- a. All trees, shrubs, cornstalks, sod, and other vegetation are to be removed and disposed of according to *SSHC Section 202*. After cornstalks and tall grass are cut and removed, the area within the limits of construction is to be thoroughly disced and scarified.

3. Deposition of Embankment Material

- a. On projects where a slope is being widened, "benching" will be required.
- b. Hauling units should be directed over a fill so that uniform compaction will result.
- c. The self-propelled tamping type roller may be used on the embankment area for leveling as long as the unit follows the prescribed rolling pattern, does not spin the power drums, and accomplishes both rolling and leveling to the satisfaction of the Project Manager.
- d. Decisions and unusual situations should be recorded in the field book.

4. Compaction

- a. Embankments shall be compacted as prescribed in *SSHC Subsection 205.03*.
 - (i) Class I embankments are to be rolled when specified by special provisions or plans; no moisture-density/deflection tests required.
 - (ii) Class II embankments require rolling; no moisture-density/deflection tests required.
 - (iii) Class III embankments require moisture-density/deflection control. The moisture content of soils being handled for these embankments is very important because the objective is to stabilize soils and improve their engineering behavior by compaction. Maintaining a soil to near "optimum moisture" during

grading operations will reduce the time and compaction effort necessary to obtain the required deflection or density.

- Note:
- Class I and II embankments require only enough moisture in the soil to attain a compaction acceptable to the Project Manager.
 - Class I - no moisture requirement by *Specifications*.
 - Class II - drying only required if necessary to obtain compaction.

- b. Moisture control; water acts as a lubricant and helps the soil particles move relative to each other into a denser condition when compaction effort is applied. Dry soils must have water added and be thoroughly mixed before compacting. A general guide would be to add water to silt-clay soils when lab or field tests indicate moisture content is five percent or more below the optimum.
- c. When wet and dry soils are placed in the same lift, they should be disc blended to a uniform condition prior to compaction.
- d. Soft Ground; embankments that cross low wet areas may require an initial stabilization layer which may consist of granular material or a combination of granular material and geotextile or geogrid. The Geotechnical Engineer should be contacted to determine the stabilization requirements. Compaction should proceed with caution. In general, the use of vibratory rollers should be discouraged since the vibrations may cause underlying soil to pump into the granular fill. In some areas, capillary action will move moisture into the upper grade by equipment moving on it. Contact Materials & Research when you encounter this situation and it is not covered in the Plans.
- e. HELPFUL HINTS
 - (i) Sand embankment directly deposited by dredge pipe will obtain proper compaction by the transporting water flowing through the fill. For this method of placing sand, other methods of compaction may be required. Testing should be done at regular intervals and recorded in the field book. The time for this test is just after the free water leaves the top 200 mm (8 inches) of fill and can be done very quickly with a LWD.
 - (ii) Sand lifts should be placed the full width of the embankment. If this cannot be done, a sand trench drain should be placed to eliminate ponding water.
 - (iii) If soils are too wet, compactive effort increases the pore water pressure and holds the particles apart. The upper limits on moisture has been set above optimum and recommendations are based on the type of surfacing or embankment designed. (Requirements are shown on the plans and/or in design files).
 - (iv) Wet soils can become elastic and result in heaving or pumping of the embankment when loads are applied. This is caused by water pore pressure and the strength of the soil is substantially reduced.

If the embankment has not been damaged, equipment should stay off of the area long enough to allow excess pore pressures to dissipate naturally. If loading were to continue on wet soil, it may have shear failure or rutting. The Project Manager should explain to the contractor that continued operations can only worsen the situation and require removal. Take a moisture measurement to show the contractor that the soils moisture content is rising and to document that the contractor is damaging the soil.

- (v) The contractor should be encouraged to route hauling equipment as evenly as possible over the entire surface area of the embankment during soil placement. This will reduce possible rutting or damage caused by heavy equipment following one path.
- (vi) The LWD for moisture and deflection determination may be used.

5. Moisture Curves

- a. When a grading inspector is not sure which moisture curve to use, they should review the available soils information at the location in question. If a curve is not available, the grading inspector should perform a control strip and submit sample to Branch Lab.

6. Construction of Embankment Toe Berms

- a. If the plans require a berm, it should be constructed at the same time as the embankment.
- b. Toe berms are built in areas where the roadway is used as a dam for a pond. In these areas the berm is used to protect the embankment from saturation by the standing water. Also to help construct fills on unstable ground. Proper compaction and soil types are needed to reduce permeability of the fill.

7. Construction of Bridge Approach Fills

- a. Toe stakes should be set and the slopes and the centerline checked during the construction of the embankment. The slopes should be finished to the lines and grade called for in the plans.
- b. In the construction of these berms, particular attention should be given to prevent the incorporation of rocks over 4 inches (100 mm) in diameter as the lifts are placed. Rocks cause extreme difficulty when driving piling or preboring for piling.
- c. The removal of boulders greater than 40 inches (1 m) in diameter in bridge berms should be covered as "extra work".
- d. Bridge approach fills should be constructed to grade with adequate length along the centerline for the bridge contractor to work. This length should be adequate for the bridge contractor's storage of material. Usually 100 to 150 feet (30 to 45 m) are adequate. This can be shortened by mutual agreement between the contractors.
- e. On some projects settlement plates are required along with delay periods for abutment construction. The settlement plate readings are sent to the Geotechnical Engineer for comparison with the design settlement predictions. In cases where the settlement differential is minimal (near the

end of the delay period), the delay period may be reduced with the Geotechnical Engineer's approval.

8. Earthwork-Measured-in-Embankment

- a. Payment for embankment in place will be based on the plan quantity.
- b. Sections of deep fills may have the quantities adjusted, based on settlement plates. These settlement plates should be well protected to insure that they are not damaged or destroyed.
- c. A graph may be plotted with fill height vs. settlement to determine settlement at intermediate heights of fill. Using this chart, the settlement below the original ground line can be determined and plotted. The volume between the plotted settlement line and original ground can then be calculated using the average end cross section method. This volume is added to the plan quantity for final payment.

9. Prewatering Plan

- a. The contractor shall present a prewatering plan at the pre-construction conference when prewatering is required. The plan should be approved by the Project Manager.

10. Payment for Water for Embankment Construction

- a. When water is required for compaction of embankments other than Class III, it should be paid for as extra work if no contract item has been provided.
- b. When water is required for moisture and density control, the cost of adding and incorporating water is a part of the item.

11. Finishing

- a. Finish grading must be completed on a timely basis so that erosion control measures may progress satisfactorily. Subsection 204.02 limits the surface area that the contractor may disturb. This area is 18 acres, (72,000 m²) excluding areas to be paved, plus an equal amount of clearing and grubbing area may be opened up. The Project Manager may increase these limits but only by written notice to the contractor. If used, this written notice should include justification for the increase and special procedures the contractor must use to safeguard the environment. Copies of this notice must be forwarded to the Construction Engineer and the District Engineer. 18 acres, (72,000 m²) is equal to approximately 1 mile (1.6 km) on an average two-lane, full grading project. Any repair required on sections that have been tentatively accepted will be considered extra work (unless considered to be the fault of the contractor) and if performed by the contractor they are entitled to additional pay as provided for in *SSHC Subsection 109.05*. Therefore, final cross sections may be taken on a section of grading after it is tentatively accepted per *SSHC Subsection 105.13*.

- b. If the finishing work is not performed on a timely schedule, the Project Manager is advised to follow these progressive steps:
 - (i) Project Manager should notify the contractor of the concerns in writing.
 - (ii) If this does not obtain results, suspend estimate payments.

12. Tentative Acceptance

- a. Areas that have been final graded may be accepted by the Department. However, do not accept an area until silt fence, cover crop, erosion checks, and other erosion control measures are in-place. Do not tentatively accept areas where the contractor must operate equipment to do other requirements. For example, shoulders and foreslopes should not be accepted until pavement and shoulders are finished. Ditch bottoms are a questionable area for tentative acceptance. Often, the Contractor plans to use material in the roadside ditch bottom to build the shoulder. In these cases, do not tentatively accept the ditch bottom until the shoulder work is also complete.

205.04 METHOD OF MEASUREMENT

- 1. Final cross sections should be taken as soon as possible to prevent any changes in ditch elevations due to erosion. On phased projects, final cross sections should be taken on each phase graded.
- 2. The following pay items are eligible to have the method of measurement converted from field measured to established quantity:
 - o Excavation Cubic Yard (CY)
 - o Excavation Borrow Cubic Yard (CY)
 - a. Provided that the following requirements are met:
 - (i) The grading has been built according to plan, or any changes to the plans have been documented by plan revision and/or change order.
 - (ii) The contractor has agreed, in writing, to the change in method of measurement.
 - (iii) The established quantity has been verified via random “spot checks” of the final grade or other methods as approved by the District Construction Engineer. A record of the verification checks should be stored in OnBase® under the NDOT DIST Pay Items document type.
- 3. A Change Order Supplemental Agreement will be required to change the method of measurement from field measured to plan quantity. Only the method of measurement should be changed, the original pay item should not be modified.
- 4. This is not to be interpreted as an all-or-nothing policy. Areas of earthwork which can't be verified or for which no agreement can be reached may be excluded from the change order and field measured.

205.05 BASIS OF PAYMENT

1. Progress payments should be kept up to date and estimated accurately to determine the proper Fuel Cost Adjustment.

206.00 ROADWAY GRADING

206.01 DESCRIPTION

1. This work consists of furnishing material and constructing roadway sections.

206.02 MATERIAL REQUIREMENTS

1. All material shall be supplied by the contractor as prescribed in Section 205.

206.03 CONSTRUCTION METHODS

1. Fills shall be constructed as prescribed in Section 205

206.04 METHOD OF MEASUREMENT

1. Final measurement is by the station as shown in the plans.

206.05 BASIS OF PAYMENT

1. Final payment includes all equipment, labor and materials, including water, necessary for compaction.

207.00 SALVAGING AND PLACING TOPSOIL

207.01 DESCRIPTION

207.02 MATERIAL REQUIREMENTS

207.03 CONSTRUCTION METHODS

1. Stripping, Salvaging, and Spreading
 - a. The areas of stripping, salvaging, and spreading of topsoil should be identified on the plans or Special Provisions.
2. Topsoil on Roadway Cuts and Embankments
 - a. Where sand pockets are encountered on backslopes and where sand is used for embankment, every effort is made by Roadway Design to place topsoil on these areas. Where these situations are missed, every effort should be made by the Project Manager to obtain topsoil for use as cover for the sand areas. If no topsoil is available, see plans for proper erosion control.

207.04 METHOD OF MEASUREMENT

207.05 BASIS OF PAYMENT

1. As topsoil is removed and stockpiled, the contractor may be paid at one half the item unit price on the progress estimate. At the time the topsoil is spread and finish graded, the remaining one half may be paid on a progress estimate.
2. Topsoil quantity is based on the area where the topsoil is placed. The excavation volume is not adjusted when the project has topsoil as a pay item.

208.00 BORROW AND WASTE SITE RESTORATION

208.01 DESCRIPTION

208.02 CONSTRUCTION METHODS

208.03 METHOD OF MEASUREMENT

208.04 BASIS OF PAYMENT

209.00 OVERHAUL

209.01 DESCRIPTION

1. SSHC Section 209 outlines the three conditions that must be met when overhaul will be considered for payment. Any material needed from outside the design section due to a design change should have overhaul determined using the center of mass calculation. The same procedure should be followed where possible.

209.02 METHOD OF MEASUREMENT

1. Overhaul has to be field calculated for final payment quantities. To determine the overhaul distance, calculate a length between the center of mass of the cut and fill minus the greater of the average haul distance or free haul distance.

209.03 BASIS OF PAYMENT

1. Payment shall be at rate shown in the current specification.

DIVISION 300

**SUBGRADE
PREPARATION,
FOUNDATION COURSE,
BASE COURSE,
SHOULDER
CONSTRUCTION AND
AGGREGATE SURFACING**

DIVISION 300
SUBGRADE PREPARATION, FOUNDATION COURSE, BASE COURSE,
SHOULDER CONSTRUCTION AND AGGREGATE SURFACING

301.00 GENERAL REQUIREMENTS

1. This section covers the general requirements for the preparation or construction of:
 - a. Subgrade and base course layers that support both asphaltic concrete and Portland cement concrete pavement surfacing,
 - b. Earth shoulders and medians, and
 - c. Aggregate surfacing and associated dust control (when applicable).
2. Performance and durability of both concrete and asphalt pavements are highly dependent upon the quality of the base and subbase materials upon which they are constructed. However, there is a difference in how base/subbase problems affect concrete and asphalt pavements. Asphalt pavements are more forgiving to inconsistencies in base stiffness, but perform better on a stiff base system. Conversely, concrete pavements experience more problems with an inconsistent base stiffness (having hard or soft spots) but can tolerate overall less-stiff base systems.
3. The Construction Technician will inspect and control fine grading and subgrade preparation as required by the plans and contract provisions. Grade stakes for trimming, if required, will usually be set by a construction survey party. The Project Manager and/or the construction technician will check the design gradation and proportions.
4. The Construction Technician should be able to determine all project transitions and the complete roadway layout. They should anticipate that the prime contractor will need "paving hubs" once the grading contractor has the grade within 3 – 3 ½ inches (75-90 mm) of the final grade. The "paving hubs" once placed should clearly define the roadway. If any points do not fit as anticipated, the Construction Technician should check the points with the survey crew and, if necessary, the Project Manager.
5. Late in the construction season, drying conditions are less than favorable due to short days and cool weather. Wet subgrade will prevent paving progress and may delay the opening of new sections of pavement until the following year. Fly Ash may be used to dry and stabilize unsuitably wet soils. Consult the Pavement Engineer for guidance.

302.00 SUBGRADE PREPARATION AND SHOULDER SUBGRADE PREPARATION

302.01 DESCRIPTION

1. The item of work "Subgrade Preparation" is designated as the procedure to be followed in preparing the grade on which pavement surfacing will be directly constructed.
2. This work provides for adjusting grade lines, scarifying, drying, shaping and compacting of the upper 6 inches (150 mm) of the roadbed ahead of surface or

base construction. The moisture and density requirements will be shown in the plans.

302.02 MATERIAL REQUIREMENTS

302.03 CONSTRUCTION METHODS

1. Since the performance of these items is accomplished to prepare the subgrade to support rigid or flexible pavement, and since the performance of either type of pavement is strongly affected by the moisture and deflection/density conditions of the subgrade at the time of placement of the pavement, the inspection of work under this subsection is of the highest importance. While staying within the compaction requirements, moisture and deflection/density limits, the following points should be kept in mind:
 - a. In order to avoid roughness due to differential heave, subgrade soils should have uniform moisture and densities.
2. Studies have shown that a wide range of moistures and densities may be found in subgrades thought to be uniformly compacted to the satisfaction of the construction inspectors. It is believed that this lack of uniformity may to some extent be due to the tendency to take samples in locations thought to be representative (thus actually being a median condition) rather than taking samples at random locations. See [Materials Sampling Guide](#) for directions on how to sample the subgrade.
3. Another problem which may result in improper moisture and deflection/density control is the erroneous identification of the soil type. A review of the Materials & Research ["Earthwork Certification Training Reference Material"](#) is recommended.
4. Settlement of shoulder pavement relative to the driving lanes and a resulting maintenance operation to eliminate a drop-off condition is quite common. Extra care in compaction of subgrade adjacent to the pavement edge is necessary to alleviate this problem area.
5. It is particularly important to test the portion of the roadbed which will underlie the outer edges of the surfacing. If the moisture or deflection/density of this outer portion is less than satisfactory, difficulty may be experienced in properly constructing and compacting the overlying pavement.
6. The Specifications require that the correction of failures below the upper 6 inches (150 mm) of the subgrade will be performed on an "Extra Work" basis.
7. After the operations of Subgrade Preparation, Shoulder Subgrade Preparation and Subgrade Trimming are completed, the Project Manager should arrange to measure the cross sections of the trimmed subgrade surfaces. The measurements should be taken at 2 feet (600 mm) intervals across the subgrade from side to side and the results recorded in the inspector's notebook. The sections should be taken with a tight string line stretched across the top of the forms or across the reference lines and measurements made to the nearest 3 mm (1/8 inch) 1/8 inch (3 mm) from the cord to the subgrade. In some cases, such as stringless paving, it may be advantageous to perform this checking by instrument which is an acceptable method.
8. At the beginning of the operation, checks should be made to assure that the equipment is in proper adjustment and the operating ability is such as to produce

the desired template. As a minimum, after having checked the beginning operation, the template should be checked each 1000 feet (300 m) and the results recorded in a field book. In the case of urban work, or when the performance of the work is such that it is questionable, the frequency of checks should be substantially increased to assure the correctness of the grade. The contractor should be informed of any areas that will need correction before subsequent operations proceed.

9. Any damage to the prepared subgrade prior to placement of the overlying pavement shall be corrected by the contractor at no additional cost to the Department.
10. The special provisions or plans may require the application of a prime coat after the trimming operation has been completed. The Project Manager may desire a prime coat due to actual job conditions when one has not been provided for. The District Engineer may be consulted for advice and for procedure when a prime coat is needed and has not been provided for in the project documents.
11. The preparation of the subgrade under the pavement approaches is not measured and paid for directly but is considered subsidiary to the concrete pavement. This is intended to apply to approach slabs placed on new subgrade and not to the existing subgrade found after the removal of existing approach slabs.
 - a. When existing approach slabs are removed and the existing subgrade must be corrected, corrective work at depths greater than 6 inches (150 mm) shall be paid for as "extra work" (as per *SSHC Subsection 302.05*, Paragraph 5).

302.04 METHOD OF MEASUREMENT

1. Note in the *SSHC Subsection 302.04* that when measured by the square yard (square meter), the area is the plan quantity for the overlying paved surface. When measured by the station, each shoulder is measured separately without regard to width (100 m or 100 foot stations).

302.05 BASIS OF PAYMENT

303.00 SUBGRADE STABILIZATION

303.01 DESCRIPTION

1. The principal function of subgrade stabilization is to stabilize existing granular subgrade soil (sand) by the incorporation of cohesive soil to provide a stable grade for subsequent construction.

303.02 MATERIAL REQUIREMENTS

1. See the [Materials Sampling Guide](#) for sampling and testing requirements.

Obtaining Materials From Local Pits

1. In general, the contractor must obtain all off site pits and close them with the landowner. The Department no longer tracks site releases for contractor provided pits.

303.03 CONSTRUCTION METHODS

1. This item consists of the stabilization of non-cohesive sand by the addition of a natural soil binder material. In order to ensure satisfactory performance of the overlying pavement, especially if it is of the flexible type, the following points should be kept in mind:
 - a. Silt clay soils exhibit poorer support for pavement if they exist as thin layers over pervious sands than if they comprise the full depth of the subgrade. For this reason, the placement of a thin soil binder layer over the sand should be prohibited.
 - b. The minimum amount of soil binder required to support construction operations should be used. An excessive amount of binder causes the mixture layer to act as a silt-clay layer as in 1 above and impedes drainage.
 - c. Thorough mixing of sand and soil binder is necessary for good performance.
 - d. A stabilized subgrade will allow paving equipment to travel over sandy areas.
2. The inspector should carefully check the contractor's equipment and calibrations. Pay quantities and other important measurements may be based on some of the equipment and we need to make certain that they conform to the requirements of the Specifications and the special provisions.

303.04 METHOD OF MEASUREMENT

303.05 BASIS OF PAYMENT

304.00 EARTH SHOULDER CONSTRUCTION

304.01 DESCRIPTION

1. Earth shoulder construction is the work of constructing earth fill directly adjacent to new pavement and rehabilitated pavement having a finished grade raise more than 1/2 inch (such as a mill 2 inch, fill 3 inch asphalt overlay). This work is performed separate from general grading operations, after the construction/rehabilitation of the adjacent pavement.

304.02 MATERIAL REQUIREMENTS

1. Material trimmed from a lime, fly ash, or other chemically stabilized soil should not be used for earth shoulder construction as it will impede plant growth

304.03 CONSTRUCTION METHODS

1. Signs, delineators, mailboxes and guardrail will usually need to be removed from the areas where the contractor is required to perform this item of work. Department maintenance forces may be required to move the signs, delineators, and guardrail. There generally will be instructions in the contract stating the disposition of the delineators and guardrail and who is responsible for the relocation. The mailboxes should be moved by the owner. It is a good policy to discuss the anticipated conflicts affecting mail deliveries with the postmaster for the area before actual construction begins. The Project Manager or inspector will have to contact the mailbox owners and coordinate the relocation of these

mailboxes so that inconveniences will be held to a minimum for all parties involved. The Department's or contractor's employees should not move these mailboxes except with the permission of the owners. If the owners will not cooperate, the postmaster for the area should be contacted.

2. Safety and protection of the highway user is a prime concern. The Standard Plans require Type II barricades if the vertical drop-off at the edge of the traveled way is more than 2 inches (50 mm).
3. Certified flaggers are required when the normal flow of traffic must be interrupted. All slow equipment as defined in the Nebraska Rules of the Road shall display the slow moving vehicle emblem and have strobe or flashing yellow beacons. The contractor must erect and maintain all the required signs and barricades in the correct positions to protect and warn the motorists. The Project Manager should take photographs and video tape the construction zone to document conditions.
4. The inspector shall take sufficient measurements and make sufficient observations to confirm that the shoulders have been constructed in reasonably close conformity with the typical section. These conforming checks shall be recorded in the daily work report. One check per 1/2 mile (1.0 km) highway centerline distance shall be the minimum number of checks required.
5. The time limitations imposed by the Specifications in Table 304 and Subsection 304.03 on placing the shoulders should be enforced. The tally of days (internal) charged against the shouldering must be shown on the weekly working day report.
6. The intent of the time limitations is to prevent a vertical drop off greater than 2 inches (50 mm). If the contractor is able to construct a satisfactory beveled edge or earth wedge, the Project Manager may waive the tally of days and assessment of damages. This should only be allowed if it allows the removal of the barrels protecting the drop off and satisfactory progress is being made to complete the shoulder.

304.04 METHOD OF MEASUREMENT

1. Plan stationing may be used for computing shoulder construction except in cases where apparent errors in stationing are discovered and the correct stationing is to be used.
2. Calibration of water measuring equipment is discussed in the *SSHC Section 205*.
3. Note in the *SSHC Subsection 304.04* that shoulders are measured by the station and each shoulder is measured separately without regard to width and depth.

304.05 BASIS OF PAYMENT

305.00 CRUSHED ROCK BASE COURSE

305.01 DESCRIPTION

1. The contractor shall furnish, place, shape and compact a course of crushed rock and rock screenings on a profiled subgrade.

305.02 MATERIAL REQUIREMENTS

1. Crushed rock and crushed rock screenings shall conform to the requirements of SSHC Subsection 1033.02, Paragraph 7., and Table 1033.08

305.03 CONSTRUCTION METHODS

1. The crushed rock and crushed rock screenings for base course shall be hauled, distributed, spread, and compacted until no further compaction can be obtained. Water may be used as needed to achieve compaction.

305.04 METHOD OF MEASUREMENT

1. Crushed rock and crushed rock screenings for base course shall be weighed on approved scales and each load delivered to the project shall be accompanied by a scale ticket.

305.05 BASIS OF PAYMENT

Crushed Rock for Base Course	Ton
Crushed Rock Screenings for Base Course	Ton

306.00 GRANULAR FILL

306.01 DESCRIPTION

1. Granular fill may be used as a drainable road base in areas with significant moisture issues. If granular fill is used to replace unsuitable material, be sure to make sure it is drained.

306.02 MATERIAL REQUIREMENTS

1. The granular material shall meet the requirements found in SSHC Subsection 1033, unless otherwise specified in the contract.

306.03 CONSTRUCTION METHODS

306.04 METHOD OF MEASUREMENT

306.05 BASIS OF PAYMENT

307.00 FOUNDATION COURSE

307.01 DESCRIPTION

1. There are currently 3 types of foundation course; Bituminous, Crushed Concrete, and Aggregate Foundation Course – D. Bituminous and Crushed Concrete are generally available on site and therefore more economical and widely used than Aggregate D.
2. The principal functions of a foundation course are:
 - a. To provide a drainable base to eliminate saturation of the subgrade. Saturation weakens the subgrade and can lead to differential swell and frost heave.
 - b. To prevent pumping at joints, cracks, and edges.
 - c. To strengthen support under joints to mitigate faulting.
 - d. To provide uniform support for the entire slab to mitigate cracking.

- e. To provide a stable paving platform to allow operation of construction equipment on unstable, granular subgrades.
3. For these reasons, the construction of foundation course deserves close inspection.
4. Any time a foundation course is used, it must be drained using longitudinal pipe drains, granular subdrains, daylighting to the foreslope, or other means. Failure to adequately drain a foundation course can result in storage of water below a pavement which can be more detrimental than if a foundation course had not been constructed.

307.02 MATERIAL REQUIREMENTS

1. All samples will be washed sieve. All samples will be taken from the project grade prior to spreading operation due to potential break down of material during handling which may affect the gradation. Crushed Concrete is more susceptible to break down than Bituminous or Aggregate D.
2. All bituminous millings shall pass a 3 inch sieve and no more than 5% by weight of material shall be retained on a 2 inch sieve.
3. Crushed concrete shall meet the gradation requirements of Table 307.01. Material represented by samples with 15% or more passing the No 200 sieve will be subject to removal.
4. Aggregate D shall be a virgin aggregate and shall meet requirements of Section 307 and 1033. Aggregate D requires an approved mix design and shall meet the gradation requirements of Table 307.02.
5. Sampling procedures in the [Materials Sampling Guide](#) shall be followed.
6. Contact the Construction Office immediately concerning any material placed not meeting the above requirements.

307.03 CONSTRUCTION METHODS

1. **Preparation of Subgrade**
 - a. See plans and specifications for material requirements. Sampling procedures in the [Materials Sampling Guide](#) shall be followed.
 - b. Subgrade preparation will normally be accomplished under a contract item in *SSHC Section 302*. However, it is important that the subgrade preparation moisture and deflection/density requirements shown in the plans be maintained until the foundation course and pavement are constructed. In the event of a significant paving delay, i.e. subgrade preparation and foundation course constructed but not paved before Winter shut down, partial or complete foundation course removal may be required to verify or restore subgrade compaction requirements prior to paving in the Spring. For this reason, long paving delays are not recommended.

2. Foundation Course

- a. The contractor shall place, compact and profile the foundation course as shown in the contract.
- b. Hauling should not be permitted when moisture conditions in the subgrade are such as to cause ruts or other damage to the subgrade or contamination of the foundation course.
- c. In the laydown of foundation course, it is best to lay the full thickness in one layer when feasible. This is particularly important if the foundation course is being placed over an unstable, granular subgrade. In this case, it may be necessary to push the foundation course out over the subgrade using tracked equipment working on previously placed foundation course.
- d. Proper control of moisture content is important for obtaining uniform deflection/density. The moisture content for Bituminous and Crushed Concrete Foundation course shall be no higher than necessary to facilitate compaction to the required stiffness. The moisture content for Aggregate D Foundation course shall be determined by AASHTO T99. The foundation course shall be rolled until no further compaction can be obtained and roller marks are removed. Compaction requirements shall be established by rolling pattern using the Light Weight Deflectometer. The Department will establish a rolling pattern and set a deflection target value. The Department will monitor the rolling pattern with a LWD and adjust as necessary to obtain optimal stiffness. Follow the [Materials Sampling Guide](#) for testing frequency.
- e. Uniformity of thickness of the compacted layer is very important. Since the Specifications require trimming of the subgrade and the base course by the use of automated electronically controlled equipment, accurate thickness control must be demanded.
- f. Following the trimming operation, cross sections should be taken on the surface of the foundation course at 2 feet (600 mm) transverse intervals and at 1000 ft. (300 m) longitudinal intervals matching the locations of the cross sections taken on the subgrade and recorded in the field book. In some cases, such as stringless paving, it may be advantageous to perform this checking by instrument which is an acceptable method. The thickness of the foundation course shall be carefully measured and recorded as documentation that the thickness requirements have been met. The thickness measurements shall be considered to represent only that width constructed and trimmed in a single operation. If any of these measurements show a deficiency from planned thickness of 1/2 inch (12.5 mm) or more and if payment is to be made by the square yard, additional measurements shall be made to define the extent of the shortage.
- g. If a measurement shows a deficiency in thickness, a check measurement shall be taken 10 foot (3 m) either side of this location parallel to the centerline of roadway. If both check measurements fall within the 1/2 inch (12.5 mm) tolerance permitted, no deficiency is to be considered. If one or both are deficient in thickness, further checking shall be made at 50 foot (15 m) intervals from the original measurement and parallel to the

centerline of roadway until a thickness within the tolerance is found in one or both directions as the case may be. Between this point and the location 50 foot (15 m) back, determine the point within 10 foot (3 m) at which the foundation course is within the tolerance permitted. If both categories of deficiency occur, the same procedure shall be used to determine the beginning and ending points of the two categories. The width of the deficiency shall be considered to be the full width constructed and trimmed in that particular operation.

- h. The Project Manager shall enter all measurements and locations where made in a field notebook. In some cases a sketch may be necessary to clarify a nonpay area. Deductions in the pay quantity of the foundation course are to be computed and made by the field Project Manager.

307.04 METHOD OF MEASUREMENT

1. Foundation course will typically be measured for payment by the square yard (m²). Aggregate Foundation Course – D will be paid for by the ton when specified in the contract.

307.05 BASIS OF PAYMENT

1. Foundation course measured by the square yard (m²) is not directly measured but is the quantity of overlying pavement. (See *SSHC Subsection 307.04*)

308.00 MEDIAN CONSTRUCTION

308.01 DESCRIPTION

1. The contractor is required to furnish material as necessary, haul, compact, blade, and shape the material in conformance with the contracts typical cross section and compaction requirements. For additional information regarding Median Construction, reference SSHC Section 308

308.02 MATERIAL REQUIREMENTS

308.03 CONSTRUCTION METHODS

308.04 METHOD OF MEASUREMENT

308.05 BASIS OF PAYMENT

309.00 CALCIUM CHLORIDE TREATMENT

309.01 DESCRIPTION

309.02 MATERIAL REQUIREMENTS

309.03 CONSTRUCTION METHODS

309.04 METHOD OF MEASUREMENT

309.05 BASIS OF PAYMENT

310.00 ROCK OR GRAVEL SURFACING

310.01 DESCRIPTION

1. This work consists of placing aggregate for a wearing course on an approved roadbed or on a newly built earth grade or on detours temporarily in use during construction. The aggregate surfacing shall be spread to meet the requirements shown in the plans or as directed by the Project Manager.

310.02 MATERIAL REQUIREMENTS

1. Sampling and Testing - Aggregates shall be sampled, tested or submitted for testing in accordance with the Materials & Research [Materials Sampling Guide](#). The inspector should read and become familiar with *SSHC Sections 310 and 1033*, and the special provisions of the contract.
2. The inspector will be responsible for sampling and testing of aggregate on the project. In some cases, when aggregate is supplied by a large producer, the District Engineer will have an inspector available at the pit site to test the material before it is shipped. However, even though some testing is performed at the source, testing will be required on the project in order to calculate the payment to the contractor (*SSHC Subsection 310.05*).

310.03 CONSTRUCTION METHODS

1. Equipment
 - a. The inspector should inspect the contractor's equipment before starting. Each truck should be carefully measured and the capacity computed by the inspector. These capacities, truck numbers, etc., should be recorded in a field notebook. The measurement and capacities are reported to the District Engineer on a NDOT Form 101. For additional information in regard to the measurement of trucks.
 - b. The specifications provide that the contractor shall secure all permits and licenses, pay all charges and fees, and give all notices necessary and incident to the due and lawful prosecution of the work. District Offices have current copies of the laws and load limits and questions concerning legal loads should be directed to the District Offices.

The Project Manager and inspector shall also be familiar with and see that the contractor adheres to the provisions of *SSHC Subsection 105.11, Restrictions on Moving and Use of Heavy Equipment*.
 - c. The load capacity for which the truck is licensed is indicated on a sticker pasted on the license plate and should be checked against the license certificate carried in the cab. Mass capacity will vary according to the number of single or tandem axles and will be specified for the truck's gross mass.
 - d. All trucks used on the project in connection with the performance of the work are required to be licensed in Nebraska regardless of the fact that they may be properly licensed in some other state. Trucks used only in hauling equipment or materials from outside the state to the project are covered by reciprocity and may not be required to be licensed in Nebraska.

- e. Violations should be called to the contractor's attention. In the event that the contractor does not take steps to comply, the Project Manager shall immediately advise the District Engineer by letter with a copy to the contractor. Letters reporting violations shall include the name and address of the owner, make, type and license numbers of the vehicles and an explanation of the violation involved. This information will be referred to the proper authorities for investigation.
2. Hauling and Distributing Materials
- a. Hauling Materials. No more than two different truck box capacities will be permitted unless approved by the Project Manager. No hauling shall be permitted when weather or roads are such that hauling causes excessive rutting. When aggregate for detours is required, it is advisable to go over the detour road with the District Construction Engineer to see what road defects need correction before the aggregate is placed.
 - b. Staking for the Distribution of Materials - In order that the contractor may know where on the road to place aggregate, stakes should be set along the shoulder which is to receive the aggregate at the load distance spacing. If it should occur that it is not desirable to place aggregate continuously, two stakes driven vertical should be set at the beginning and ending of each series of loads, two stakes driven to form a "X" may be used to mark each tenth load. One load should be spread between each pair of stakes, and instructions should be issued to the contractor to leave a small gap between loads so that you may be sure that all loads are placed as staked. When trucks of more than one capacity are used, stakes shall be set for each size in sections rather than intermingling the different sizes. One size usually takes the long haul and the other the short. Consult the plan for the width and depth of the aggregate to be placed.
 - c. When placing aggregate on a newly graded project, the number of loads staked in any given distance shall be checked against the project station reference stakes. When placing aggregate on an unreferenced detour, the number of loads per mile (kilometer) staked should be checked against the number of cubic yards (cubic meters) required per mile (kilometer).
 - d. Inspection Costs - In order to avoid excessive inspection costs, particularly on other than high production operations, it may be necessary to control the placement and inspection operations as follows:
 - (i) When a single aggregate, or separate aggregate materials are being deposited on both long and short haul sections, or on separate sections of the project, one inspector located at the short haul placement point may observe and inspect the loads destined for the other, or longer haul sections.
 - (ii) The inspector staking and inspecting the delivery of the aggregates may also take necessary material samples and check the gradation of the aggregate.

- (iii) If the material placement rate is so low as to create uneconomical and wasteful inspection costs, the headquarters or District Office should be contacted for special instructions.

310.04 METHOD OF MEASUREMENT

1. When rock or aggregate for surfacing is specified by the cubic yard it will be measured in trucks with struck loads. This measurement will be made at the point of delivery.
2. When rock or aggregate for surfacing is specified by the ton, it will be measured by approved scale tickets. No deductions for moisture will be made.

310.05 BASIS OF PAYMENT

1. This material is now paid for according to *SSHC* Table 310.01. If there is a deduction it will be computed and deducted from the contract unit price and that lot must be shown as a contingency item on the estimate with the computed unit price.
2. Maintenance of temporary surfacing is paid for with equipment rental pay items.

311.00 FURNISH ROCK OR GRAVEL

311.01 DESCRIPTION

311.02 MATERIAL REQUIREMENTS

311.03 CONSTRUCTION METHODS

311.04 METHOD OF MEASUREMENT

311.05 BASIS OF PAYMENT

312.00 REMOVAL AND PROCESSING OF CONCRETE PAVEMENT

312.01 DESCRIPTION

312.02 MATERIAL REQUIREMENTS

312.03 CONSTRUCTION METHODS

312.04 METHOD OF MEASUREMENT

312.05 BASIS OF PAYMENT

Subgrade Preparation, Foundation Course, Base Course, Shoulder Construction and Aggregate Surfacing

CONVERSION FACTORS

To Convert Tons of Material to Cubic Yards

Divide By

Crushed Sand Gravel	1.20 Tn/CY
Fine Aggregate for Concrete	1.30 Tn/CY
Coarse Aggregate (Limestone) for Concrete	1.25 Tn/CY
Sand-Gravel for Concrete; Surfacing Gravel or Crushed Rock	1.35 Tn/CY
Crushed Rock for Base Course	1.25 Tn/CY
Crushed Rock for Base Course Screenings	1.25 Tn/CY
Mineral Filler and Soil Binder	0.85 Tn/CY

To Convert Megagrams of Material to Cubic Meters

Divide By

Crushed Sand Gravel	1.30 Mg/m ³
Fine Aggregate for Concrete	1.54 Mg/m ³
Coarse Aggregate (Limestone) for Concrete	1.48 Mg/m ³
Sand-Gravel for Concrete; Surfacing Gravel or Crushed Rock	1.60 Mg/m ³
Crushed Rock for Base Course	1.48 Mg/m ³
Crushed Rock for Base Course Screenings	1.48 Mg/m ³
Mineral Filler and Soil Binder	1.06 Mg/m ³

Road Gravel Requirements

English Version

Width of Road-way	Sq. Yds. Per Mile	1/2" Depth				3/4" Depth				1" Depth				1 1/2" Depth				2" Depth				2 1/2" Depth				3" Dep	
		1 cu.yd.		Cu. Yds.		1 cu.yd.		Cu. Yds.		1 cu.yd.		Cu. Yds.		1 cu.yd.		Cu. Yds.		1 cu.yd.		Cu. Yds.		1 cu.yd.		Cu. Yds.		1 cu.yd.	Per
		Covers	Per	Per	Per	Covers	Per	Per	Per	Covers	Per	Per	Per	Covers	Per	Per	Per	Covers	Per	Per	Per	Covers	Per	Per	Per	Covers	Per
Lin. Ft.	Sta.	Per	Per	Lin. Ft.	Sta.	Per	Per	Lin. Ft.	Sta.	Per	Per	Lin. Ft.	Sta.	Per	Per	Per	Lin. Ft.	Sta.	Per	Per	Lin. Ft.	Sta.	Per	Per	Lin. Ft.	Sta.	
9'	5280.0	72.00	1.39	73.33	48.00	2.08	110.00	36.00	2.78	146.67	24.00	4.17	220.00	18.00	5.56	293.33	14.40	6.94	366.67	12.00	8.33						
10'	5866.7	64.80	1.54	81.48	43.20	2.31	122.22	32.40	3.09	162.96	21.60	4.63	244.44	16.20	6.17	325.93	12.96	7.72	407.41	10.80	9.26						
11'	6453.3	58.91	1.70	89.63	39.27	2.55	134.44	29.45	3.40	179.26	19.64	5.09	268.89	14.73	6.79	358.52	11.78	8.49	448.15	9.82	10.19						
12'	7040.0	54.00	1.85	97.78	36.00	2.78	146.67	27.00	3.70	195.56	18.00	5.56	293.33	13.50	7.41	391.11	10.80	9.26	488.89	9.00	11.11						
13'	7626.7	49.85	2.01	105.93	33.23	3.01	158.89	24.92	4.01	211.85	16.62	6.02	317.78	12.46	8.02	423.70	9.97	10.03	529.63	8.31	12.04						
14'	8213.3	46.29	2.16	114.07	30.86	3.24	171.11	23.14	4.32	228.15	15.43	6.48	342.22	11.57	8.64	456.30	9.26	10.80	570.37	7.72	12.96						
15'	8800.0	43.20	2.31	122.22	28.80	3.47	183.33	21.60	4.63	244.44	14.40	6.94	366.67	10.80	9.26	488.89	8.64	11.57	611.11	7.20	13.89						
16'	9386.7	40.50	2.47	130.37	27.00	3.70	195.56	20.25	4.94	260.74	13.50	7.41	391.11	10.13	9.88	521.48	8.10	12.35	651.85	6.75	14.81						
17'	9973.3	38.12	2.62	138.52	25.41	3.94	207.78	19.06	5.25	277.04	12.71	7.87	415.56	9.53	10.49	554.07	7.62	13.12	692.59	6.35	15.74						
18'	10560.0	36.00	2.78	146.67	24.00	4.17	220.00	18.00	5.56	293.33	12.00	8.33	440.00	9.00	11.11	586.67	7.20	13.89	733.33	6.00	16.67						
19'	11146.7	34.11	2.93	154.81	22.74	4.40	232.22	17.05	5.86	309.63	11.37	8.80	464.44	8.53	11.73	619.26	6.82	14.66	774.07	5.69	17.59						
20'	11733.3	32.40	3.09	162.96	21.60	4.63	244.44	16.20	6.17	325.93	10.80	9.26	488.89	8.10	12.35	651.85	6.48	15.43	814.81	5.40	18.52						
21'	12320.0	30.86	3.24	171.11	20.57	4.86	256.67	15.43	6.48	342.22	10.29	9.72	513.33	7.72	12.96	684.44	6.17	16.20	855.56	5.14	19.44						
22'	12906.7	29.45	3.40	179.26	19.63	5.09	268.89	14.73	6.79	358.52	9.82	10.19	537.78	7.36	13.58	717.04	5.89	16.98	896.30	4.91	20.37						
23'	13493.3	28.17	3.55	187.41	18.78	5.32	281.11	14.09	7.10	374.81	9.39	10.65	562.22	7.04	14.20	749.63	5.63	17.75	937.04	4.70	21.30						
24'	14080.0	27.00	3.70	195.56	18.00	5.56	293.33	13.50	7.41	391.11	9.00	11.11	586.67	6.75	14.81	782.22	5.40	18.52	977.78	4.50	22.22						
25'	14666.7	25.92	3.86	203.70	17.28	5.79	305.56	12.96	7.72	407.41	8.64	11.57	611.11	6.48	15.43	814.81	5.18	19.29	1018.52	4.32	23.15						
26'	15253.3	24.92	4.01	211.85	16.61	6.02	317.78	12.46	8.02	423.70	8.31	12.04	635.56	6.23	16.05	847.41	4.98	20.06	1059.26	4.15	24.07						
27'	15840.0	24.00	4.17	220.00	16.00	6.25	330.00	12.00	8.33	440.00	8.00	12.50	660.00	6.00	16.67	880.00	4.80	20.83	1100.00	4.00	25.00						
28'	16426.7	23.14	4.32	228.15	15.43	6.48	342.22	11.57	8.64	456.30	7.71	12.96	684.44	5.79	17.28	912.59	4.63	21.60	1140.74	3.86	25.93						
29'	17013.3	22.34	4.48	236.30	14.89	6.71	354.44	11.17	8.95	472.59	7.45	13.43	708.89	5.59	17.90	945.19	4.47	22.38	1181.48	3.73	26.85						
30'	17600.0	21.60	4.63	244.44	14.40	6.94	366.67	10.80	9.26	488.89	7.20	13.89	733.33	5.40	18.52	977.78	4.32	23.15	1222.22	3.60	27.78						

313.00 STABILIZED SUBGRADE TYPE LIME

313.01 DESCRIPTION

1. The item of work "Stabilized Subgrade Type Lime" is designated as the procedure to be followed in stabilizing the grade on which foundation course and/or pavement will be constructed.
2. The work shall consist of reshaping the subgrade, constructing and compacting an 8-inch layer of pulverized soil, hydrated lime and water to provide a firm, stable foundation for subsequent construction.

313.02 MATERIAL REQUIREMENTS

1. Pebble Quicklime or Hydrated lime shall conform to the requirements of ASTM C977.
2. Water shall conform to the requirements of Section 1005.

313.03 CONSTRUCTION METHODS

1. This item consists of the modification and stabilization of cohesive soils through the addition of lime. It is typically used to modify and stabilize cohesive soils with a moderate to high Plasticity Index (PI). The modification reduces the PI and related swell potential of the soil while the stabilization increases the compressive strength.
2. Materials & Research will provide a mix design to include the percent lime and final moisture required based on lime and soil samples provided by field personnel a minimum of 21 days prior to work. A soil sample and mix design is required for each unique soil encountered. In highly variable soils, M & R may select a single, conservative mix design to simplify construction if all samples are available at once. If soil samples are determined to be granular, stabilization quantities may be reduced or eliminated.
3. Lime may be applied through dry or slurry placement although the vast majority of work in NE has historically been the dry placement of Pebble Quicklime. Significant placement of Pebble Quicklime on grade ahead of the stabilization process should be avoided and special attention paid to weather conditions. Exposure to moisture prior to incorporation will activate the Pebble Quicklime and reduce its potency.
4. The general process is
 - a. Trim subgrade to within 1/2 inch of finished elevation
 - b. Scarify subgrade to contain lime and water
 - c. Apply lime to scarified subgrade
 - d. Pulverize soil, lime and water added by reclaimer (initial mixing)
 - e. Blade and roll to seal surface
 - f. Lightly sprinkle as necessary during 48 hour cure period
 - g. Pulverize soil a second time (final mixing)
 - h. Shape and roll to attain required moisture and density/stiffness requirements. Optimum moisture requirements are provided in the mix

design. Moisture tolerances and stiffness requirements are defined in the contract.

- i. Lightly sprinkle as necessary during 72 hour cure period
5. During initial mixing the moisture content shall be approximately 3 to 5 percentage points greater than the optimum moisture content provided by the mix design as the lime will consume several percentage points. Following a 48-hour cure period and final mixing the optimum moisture and density/stiffness requirements shall be met.

313.04 METHOD OF MEASUREMENT

1. "Stabilized Subgrade Type Lime" is measured by the Square Yards of overlying pavement rather than the actual width which extends beyond the pavement. In some instances it may be measured by the Station.
2. "Hydrated Lime" is measured by the ton and water is measured by the MGAL (1,000 gallons). Both are a measurement of the actual quantity used for the full stabilization width, rather than the overlying pavement width as shown above.

313.05 BASIS OF PAYMENT

314.00 STABILIZED SUBGRADE TYPE FLY ASH

314.01 DESCRIPTION

1. The item of work "Stabilized Subgrade Type Fly Ash" is designated as the procedure to be followed in stabilizing the grade on which foundation course and/or pavement will be constructed.
2. The work shall consist of reshaping the subgrade, constructing and compacting an 8-inch layer of pulverized soil, fly ash and water to provide a firm, stable foundation for subsequent construction.

314.02 MATERIAL REQUIREMENTS

1. Fly Ash shall be Type C and shall meet the requirements of the contract special provisions.
2. Water shall conform to the requirements of Section 1005.

314.03 CONSTRUCTION METHODS

1. This item consists of the stabilization of cohesive soils through the addition of Class C Fly Ash. Class C Fly Ash is a coal combustion by-product with cementitious properties. It is typically used to stabilize cohesive soils with a low to moderate Plasticity Index (PI) thereby decreasing swell potential and increasing compressive strength.
2. Materials & Research will provide a mix design to include the percent fly ash and moisture required based on fly ash and soil samples provided by field personnel a minimum of 21 days prior to work. A soil sample and mix design is required for each unique soil encountered. In highly variable soils, Materials & Research may select a single, conservative mix design to simplify construction if all samples are available at once. If soil samples are determined to be granular, stabilization quantities may be reduced or eliminated.

3. Due to the fine, fluid nature of fly ash, it must be applied with an appropriate spreader. A motor grader is not allowed. Significant placement of fly ash on grade ahead of the stabilization process should be avoided and special attention paid to weather conditions. Wind can easily scatter the ash and exposure to moisture prior to incorporation will activate the fly ash rendering it ineffective (similar to cement).
4. The general process is:
 - a. Trim subgrade to within 1/2 inch of finished elevation
 - b. Apply fly ash to subgrade. A windrow of soil at the edge of the intended process width may be used to contain the fly ash.
 - c. Pulverize/mix soil, fly ash and water added by reclaimer within 30 minutes of fly ash application
 - d. Complete shaping and compaction within 75 minutes of mixing to attain required moisture and density/stiffness requirements. Optimum moisture requirements are provided in the mix design. Moisture tolerances and stiffness requirements are defined in the contract.
5. Completing work within the specified timeframes is important as the fly ash acts similar to a cement. Additional work outside of the specified timeframes will begin to break the bonds that are forming thereby reducing or eliminating the stabilization effect.

314.04 METHOD OF MEASUREMENT

1. "Stabilized Subgrade Type Fly Ash" is measured by the Square Yards of overlying pavement rather than the actual width which extends beyond the pavement. In some instances it may be measured by the Station.
2. "Fly Ash" is measured by the ton and water is measured by the MGAL (1,000 gallons). Both are a measurement of the actual quantity used for the full stabilization width, rather than the overlying pavement width as shown above.

314.05 BASIS OF PAYMENT

DIVISION 400

LIGHTING, SIGNS, TRAFFIC SIGNALS AND TRAFFIC CONTROL

DIVISION 400
LIGHTING, SIGNS, TRAFFIC SIGNALS & TRAFFIC CONTROL

400.00 CHECKLIST

SSHC References: *Section 400 - Lighting, Signs, Traffic Signals & Traffic Control*

Section 203 - Removal of Structures and Obstructions

Other References: NDOT [Materials Sampling Guide](#)

National Electric Code

National Electric Safety Code

Inspection Equipment: Volt Meter

(Contact District Electronic Light Meter (Photometer)

Tech for this equipment) Flashlight

Hex Wrenches

Adjustable Wrenches

Construction Requirements: See Contract for specific details:

CONDUITS (SSHC 405.03):

1. Conduit sizes and types installed must agree with those detailed in the plans.
2. All conduit ends must have bell ends or bushings.
3. Conduit must be minimum of 30 inches (750 mm) below grade.
4. Spare conduit bend must be capped or plugged with standard fittings.

CONDUCTORS:

1. Conductors must be of the size, type, and number as detailed in the Contract. Conductors which have properties exceeding the minimum requirements, may be furnished at the contractor's option with the Project Manager's approval. No adjustment in contract price will be allowed.
2. Conductors shall be individually tagged when the conduit in which they are housed is inaccessible and cannot itself be tagged. (SSHC Subsection 402.03)
3. Conductors shall be color coded for safety and to facilitate maintenance of the lighting system. (SSHC Subsection 402.02)

PULL BOXES (SSHC 406):

1. All pull boxes with a cast iron ring and cover must be grounded with all grounding connections securely made. (SSHC Subsection 406.01)
2. Check all wire sizes in pull box.
3. All conduit entrance bends must be tagged with a permanent tag indicating direction of the conduit run.
4. All cable connections in pull boxes must be made using approved URD submersible connectors. Check for proper cable insertion into connector; that all connections are tight and that all openings are covered or plugged.

POLES (SSHC 408):

1. New light poles should not be placed directly under other overhead distribution systems.
2. All poles must have handhole covers securely fastened.
3. Power foundations are to be flush with grade. Concrete foundations are allowed a 1 inch (25 mm) chamfer.
4. All settlement of soil around pole base and along conduit runs must be backfilled and compacted. (SSHC Subsection 407.03 and 702).
5. Check for minimum of 1 foot (300 mm) cover over the grounding rod and for proper connection to the grounding rod. Contractor must use connectors detailed in the plans.
6. Check for proper grounding to pole (anchor type) or to transformer base (breakaway type). Contractor must use connectors detailed in the plans.
7. Check for spare bend on last pole of each run.
8. Check for proper mechanical cable connections in base of each pole. (Taps and taping not allowed).
9. Check for heavy flat washer between top of pole base and anchor bolt nut.
10. Check for correct "hold-down" and "connecting-washers" on pole installations using breakaway transformer bases. It is very important that the washers supplied with the base be used as instructed by the manufacturer.
11. On installations where three or more conduit bends enter the pole or transformer base, each conduit bend should be tagged. Tags to be embossed or stamped with the direction of the conduit run. On anchor base installations where the conduit entrance bends are inaccessible, each run of feeder cable should be tagged.

LIGHTING CONTROL CENTER:

1. Installation of conduit, controls, and grounding to be as detailed in plans. Verify that disconnect or relay installed is of the size and type that has been approved for use on the project.
2. Conduit or conductors should be properly tagged indicating direction of run. Conductors should be color coded.

JUNCTION BOX IN BRIDGE CURB:

1. Bushings are required on all conduits entering the junction box.
2. Junction box should be grounded.
3. Lid of junction box should be gasketed.
4. Junction boxes with more than two conduits entering the box shall have the conduits tagged to indicate the direction of the conduit run.
5. Conductors should be color coded.

TESTS ON THE COMPLETED SYSTEM:

Circuit Continuity
Voltage Drop
Ground Resistance

INSPECTOR'S RECORDS & FORMS:

AASHTOWare SiteManager DWRs
Material Certifications

POINT OF CONTACT, See appendix:

Lighting Engineer, 402-479-3842
Traffic Signal Engineer, 402-479-
Signing Engineer, 402-479-

SSHC References

Section 203 - Removal of Structures and Obstructions
Section 401 - Lighting and Traffic Signal Requirements
Section 402 - Cable Installation
Section 403 - Direct Burial Cable
Section 404 - Aerial Cable
Section 405 - Conduit
Section 406 - Pull Boxes
Section 407 - Pole and Tower Foundations
Section 408 - Poles and Towers
Section 412 - Luminaires
Section 413 - Lighting Control Center
Section 414 - High Mast Lowering System
Section 415 - Lighting System Maintenance
Section 416 - Temporary Lighting System
Section 1073 - Material Requirements

Other References:

NDOT [Materials Sampling Guide](#)
National Electric Code
National Electric Safety Code

400.01 TRAFFIC SIGNALS

1. GENERAL

- a. The following items should be emphasized during the construction of a typical traffic signal. Although most of these items are covered in the Plans, Special Plans, Special Provisions, and in Division 400 and

Section 1073 of the SSHC, they are sometimes overlooked, causing problems for future maintenance.

2. SAFETY
 - a. Make sure the contractor's vehicles and equipment are not blocking the view of motorists using the intersection during construction.
3. ELECTRICAL POWER
 - a. Arrange for electrical service early in the project, especially in larger cities like Lincoln and Omaha. Roadway Design coordinates electrical service for roadway lighting during the design process. Traffic coordinates electrical service for signals and notes it on the plans.
4. STATE SUPPLIED MATERIAL
 - a. Project Manager should check to make sure state supplied material has been shipped to the designated NDOT yard 4 weeks before installation. Check stock requisition for back ordered items. Call Traffic Engineering if anything is missing.
5. PRELIMINARY STAKING
 - a. Stake poles according to plan but avoid utilities. If poles are relocated, make sure mast arms are long enough to center signal heads in their appropriate lanes.
 - b. In urban areas there should be a minimum of 6 foot (2.0 m) clearance between the curb and the pole. In rural areas, clearance from Roadside Design Guide is used. On rural high speed (55+ mph) highway with high ADT a minimum of 30 foot clearance will be required.
 - c. Call Traffic Engineering (402-479-4594) if the poles must be moved more than 2 feet (600 mm).
6. SAW CUT LOOP LOCATION
 - a. Avoid crossing cracks and joints when locating loops. The exact size and shape of the loop is not critical. Keep the loops in the vehicle path and keep the spacing between the loops in a lane under 10 feet (3.0 m).
 - b. Call Traffic Engineering for locating the loops if there are any questions.
7. TEMPORARY SIGNAL
 - a. It is the contractor's duty to construct, maintain, and remove the signal.
8. ITEMS TO CHECK WHEN INSTALLING (TRAFFIC SIGNALS)
 - a. POLE FOUNDATIONS
 - (i) The foundation must include a ground rod, a spare conduit and a conduit for lighting. (per Standard Plan 912)
 - b. PULL BOXES (per Standard Plan 914)
 - (i) Conduit ends must have bell ends to reduce snagging of the pulled wires.

- (ii) Clean Gravel with adequate voids must be 1 foot (300 mm) deep in the bottom of the pull box for drainage. Crushed limestone or crushed concrete is not acceptable.
 - (iii) Specified pull box lids must be grounded.
 - (iv) Splices in the pull box must be raised off the bottom of the pull box (per wiring diagram).
- c. **LOOPS, PREFORMED**
 - (i) Remind the contractor to install preformed loops BEFORE paving. Sawing in the loops after paving will not be accepted. We will require the contractor to remove the pavement to a joint, place the loops in the subgrade and replace the pavement if they forget, NO EXCEPTIONS (per detector plan).
 - (ii) Remind the contractor to protect and mark the leads to the preformed loops so they are not damaged during adjacent paving.
- d. **LOOPS, SAWED**
 - (i) The saw slot must be 3/8 inch (9 mm) wide, 3/4 inch (19 mm) wide at cracks and joints to allow for the joint tube (per detector plan).
- e. **MAGNETIC DETECTORS**
 - (i) The contractor must handle magnetic detector leads gently where they join the detector to reduce cracking, if cracked, they must be replaced.
 - (ii) If the magnetic detector serves one lane, place the detector under the right wheel track. If the detector serves two lanes, center the detector between the two lanes.
 - (iii) Manufacturer recommends place for maximum coverage between 1 and 16" below pavement's surface. It is important for proper detector's operation.
 - (iv) The conduit housing the detector should slope to drain into the pull box (per detector plan).
- f. **POLES (per Standard Plan 912)**
 - (i) The pole bases must be double nutted so the pole can be plumbed.
 - (ii) The ground wire must be attached to the nut in the pole behind the handhole and to the ground rod in the pole foundation.
- g. **MAST ARMS (per Standard Plan 912)**
 - (i) Wait until the signal is turned on to install the set screw in the clamp of the mast arm, to allow for adjustment of the arm at the time of turn on. The clear height under the signal head must be 18' +/- 6" to the crown of the roadway.

h. WIRING

- (i) Span wire signal installations shall be wired with stranded wire.
- (ii) All splices must be made with the specified splice kit (per wiring diagram).
- (iii) Be sure wires are not damaged when they are stripped for splicing. Check several of the splices by bending the entire splice back and forth to see if the wire breaks, especially where the stripping of the wire starts. Check to make sure the wire insulation has not been cut where the cable sheathing has been removed. This can also be done by bending the wires.
- (iv) Splices are not allowed in a cable from the controller to the cables final destination. Wire the loop detectors for an approach in series, not in parallel.
- (v) Holes in poles and mast arms must be protected with rubber grommets prior to pulling wire. Be sure wires are not skinned or damaged while being pulled. (per Standard Plan 912)
- (vi) Do not use spade lugs on solid wire, use spade lugs on stranded wire.

i. CONTROLLER

- (i) Wires must be labeled as shown on the wiring diagram using the specified method. Examples: Loop 20, NE Pole (per wiring diagram).
- (ii) All conductors pulled into the cabinet must extend 5 feet (1.5 m) beyond the end of the conduit housing them (per wiring diagram).
- (iii) The conduit LB fitting under a pole mounted cabinet must be 62 mm (2.5 inches) or larger.
- (iv) The location of the controller should be verified in the field to ensure that it does not encroach on the pedestrian access route.
- (v) A ground rod must be installed in the concrete pad of all pad mounted controllers.
- (vi) Pad mounted controllers must contain one spare conduit.
- (vii) Make sure the cabinet doors swing as shown on the installation plans.

j. TRAFFIC SIGNAL HEADS

- (i) The minimum spacing between heads (center to center) must be at least 10 feet (3.0 m) (per Installation Details)
- (ii) The backplates and heads must be mounted PLUMB, not aiming downward.
- (iii) The backplates must be one piece and vacuum formed.
- (iv) Cover the signal heads with an opaque material prior to turn on so motorists are not confused.

- (v) LED modules from NDOT approved product list are used.
- k. PEDESTRIAN HEADS
 - (i) Mount the pedestrian heads as shown on the plans, not on the street side of the pole.
- l. PED PUSHBUTTONS
 - (i) Pushbuttons must be mounted on the correct side of the pole as shown on the plans.
 - (ii) The pushbutton signs must be worded as shown on the shop drawings with the arrow pointing in the proper direction.
- 9. FINAL SIGNAL TURN ON
 - a. Call Traffic Engineering (402-479-4594) at least 2 days before turn on, try to avoid turning on the signal on Fridays; signal failures usually occur in the first few days.
 - b. Prior to requesting a turn on:
 - (i) The power service must be installed and energized.
 - (ii) Each signal head and pedestrian head must be "flashed out" by the contractor to check for short circuits and to assure that each wire really does service the assigned signal head.
 - (iii) Check each loop wire in the cabinet for continuity.
 - (iv) Arrange with the District or local jurisdiction for STOP sign removal when the signal is turned on.
 - (v) W3-3 "Signal Ahead" signs must be installed.
 - (vi) Arrange for flagging by the police/State Patrol at turn on, if required.
 - (vii) Coordinate with Traffic Engineering for proper signal turn on procedure.

400.02 TRAFFIC CONTROL PLAN

- 1. The Project Manager shall prepare Traffic Control Plan and present it at the Preconstruction Conference. The Traffic Control Plan must be reviewed by the Traffic Engineering Division. See the [PM Best Practice Manual](#) for details and example transmittal letter.
 - a. Contract documents include references to traffic control requirements in many locations. Project plans contain references to traffic control requirements in the traffic control plan tabulation usually found on estimate of quantities sheet. Plans may also contain project specific traffic control and/or staging details.
 - b. Traffic control specification references are found in:
 - SSHC Section 422 - Temporary Traffic Control Signs and Devices
 - SSHC Section 424 - Temporary Pavement Marking
 - SSHC Section 1069 - Temporary Pavement Marking

- c. Traffic control requirements may also be found in the Special Provisions for specific construction activities.
- d. NDOT Form 502, "Construction Signs and Posts" shall be used to record the transfer of signs to a contractor.

2. TRAFFIC CONTROL SIGNING CHANGES

- a. Plan notes indicate signing changes cannot be made without concurrence of the District Construction Engineer and Traffic Engineering [(402) 479-4594]. Field flexibility is required by situations that will not fit standard traffic control layouts such as hilly terrain, permanent signs, guardrail location, or side roads and entrances impacting the location of temporary traffic control signs. Presence of unusual traffic generators that affect volume or high turning movements might also require sign location adjustments.
- b. Evaluate construction work zones prior to installation of traffic control signing, and again when operational, to look for any issues that may affect operational quality. Traffic control evaluations shall be held during work hours, on weekends, and during nighttime hours. Presence of skid marks are a good indication of an issue. Early review of proposed traffic control signing situations prior to the preconstruction conference will allow traffic control detail changes to be made prior to impacting public traffic.
- c. Make immediate changes when obvious operational issues exist, then call the District Construction Engineer and Traffic Engineering Division as soon as possible to discuss needed changes. For other than obvious operational issues that could be dangerous to motorists or workers, contact the District Construction Engineer and Traffic Engineering Division first for concurrence of any proposed changes.
- d. The following modifications to traffic control details shall not be made:
 - Do **not** shorten taper lengths
 - Do **not** change the sign word message or symbol
 - Do **not** change the sign color combination
 - Do **not** reduce sign size or alter sign shape
- e. Field adjustments can be made, if necessary, in the following areas **without** Traffic Engineering Division notification and concurrence:
 - Individual sign locations may be adjusted up to a maximum of 200 feet (60 m) as long as no two signs, either permanent or temporary, become closer than 200 feet (60 m) apart. Removal, covering, or adjusting of permanent signs in the vicinity of construction work zones should be coordinated with maintenance. Adjustment greater than 200 feet (60 m) must be approved by the District Construction Engineer.
 - Paired signs may be adjusted a maximum of 200 feet (60 m).
 - Taper location, flashing arrow panel location, and corresponding lane merge signs may be adjusted up to 500 feet (150 m) away from construction work area. This is appropriate with poor

advance sight distance exists due to hills or curves, or when earlier detection of a flashing arrow panel is needed.

3. WORK AREA SPEED ZONE

Refer to [DOT-OI 60-18](#) for further instructions. NDOT Form 471 needs to be filled out when there is a Work Zone Speed Zone in effect.

4. STOP SIGNS ON CONSTRUCTION PROJECTS

a. Particularly during grading activities, the need arises to move stop signs as intersections are staged to allow access into project corridors. Instructions regarding the placement of stop signs during grading activities are as follows:

- Existing stop signs should be left in place until work in that area necessitates removal. If an intersection does not have an existing stop sign, the appropriate maintenance supervisor should be notified to install a stop sign immediately. All side roads to primary highways must have a stop sign unless the side road is physically closed. The temporary stop sign should be installed prior to removal of the existing stop sign.
- At the time work progresses to the point that an existing stop sign is no longer in the proper location or is in the way of construction activities, the stop sign should be removed by NDOT Maintenance. A temporary stop sign placed by the contractor. Temporary stop sign should be mounted according to details shown on Standard Plan 920. This sign may be moved as needed to allow construction to proceed, but must be maintained in an effective position at all times traffic is staged through the intersection.
- When work at the intersection is completed to the point where the permanent stop sign can be installed, NDOT Maintenance should be notified to install the permanent stop sign. This notification should be given on an intersection by intersection basis and not delayed until entire project is completed.

5. NO PASSING ZONES ON CONSTRUCTION PROJECTS

a. Often it is necessary to place temporary no-passing zones through a traffic control zone. To aid in the proper use of no-passing zones follow these guidelines:

- Never shorten an existing no-passing zone for temporary traffic control.
- If an existing no-passing zone is lengthened, a black on orange "No Passing Zone" (W14-3) (pennant) sign should be erected at the beginning of the no-passing zone and the existing black on yellow "No Passing Zone" (W14-3) sign should be removed or covered.
- If a temporary no-passing zone falls within an existing no-passing zone, no additional signs should be added. Either the existing

black on yellow "No Passing Zone" signs can remain or they be replaced with black on orange "No Passing Zone" signs.

- If a no-passing zone ends within 300 feet (90 m) of the beginning of the existing no-passing zone, then both no-passing zones should be connected to make one continuous no-passing zone. Only one "No Passing Zone" sign should be placed at the beginning of continuous no-passing zone.

6. CONSTRUCTION WORK ZONE SIGNING DURING WINTER SHUTDOWN

- a. Responsibilities of the District Construction Engineer (DCE), District Maintenance Superintendent, and the contractor for highway projects not fully completed by winter shutdown are reviewed below.
- b. Unless contract documents identify signing responsibilities different than stated herein, the following guidelines will apply. Unusual circumstances will be handled on a project specific basis with approval of the Construction Division.
- c. Uncompleted Projects
 - (i) This category of projects includes contracts having some carry-over work into the next year or intended by plan to be multi-year contracts.
 - Prior to winter shutdown, the DCE, PM and NDOT Maintenance personnel should field review the project to identify access, signing, and safety features needed to be completed before the contractor suspends work. The DCE and NDOT Maintenance will decide which items are contractor's responsibilities and what is best accomplished by NDOT Maintenance forces. Depending on the Special Provision, during the winter shutdown period, traffic operation services may become the responsibility of the NDOT Maintenance. This includes routine surveillance and sign maintenance.
 - Snow removal for through traffic and local accesses, if needed, is the responsibility of Maintenance.
- d. Special Concerns
 - (i) When temporary traffic signals are involved, the contractor shall arrange for emergency maintenance services. Maintenance of the temporary traffic signal is included in the item. Therefore, no additional payment will be made to contractor.
 - (ii) On urban projects, DCE will need to coordinate with the city to determine who is responsible for access, signing, and safety features.

400.03 EQUIPMENT AND MATERIAL STORAGE

1. When maintaining through traffic on construction projects, equipment and materials stored within the right-of-way during nonworking hours should normally be stockpiled the prescribed distance from the traveled way. Storage areas will be allowed in the following locations:
 - a. Beyond 30 feet (9 m) of traveled way on high speed sections of highways. Ideally, storage areas should be beyond 50 feet (15 m) of traveled way on interstate highways. (SSHC Subsection 107.07)
 - b. Other storage locations may be approved by Project Manager when it is not practical to satisfy the above criteria. Other locations must be shielded by temporary concrete protection barrier or guardrail.
 - c. Storage behind barriers should provide for movement upon impact; the clear area behind barriers in high speed locations; for thrie-beam guardrail is 3 feet on parallel sections; in bullnoses 65 feet from the nose; and 4 feet for W-beam. For cable guardrail, 12 feet should be clear of obstructions behind the cable. For low speed (posted 45 mph and less) urban locations the clear area may be 50% of the values shown.
 - d. Material & equipment may be placed immediately behind the bridge rail and concrete median barrier.

400.04 BRIDGE APPROACH GUARDRAILS

1. On construction projects that require the removal of guardrail at the approaches to bridges, or if the guardrail has not yet been installed, per Standard Plan 921, the following minimum traffic controls should be in place at all unprotected bridge ends whenever traffic is permitted to use the highway:
 - a. Two-lane, two-way condition
 - (i) Three Type III barricades should be in place to the right of the lane approaching the bridge. The barricades should be placed at 50 ft (15 m) spacing, with the last barricade placed at the unprotected bridge end. One Type III barricade should be in place to the right of the lane leaving the bridge (facing traffic approaching from the opposite direction). The barricade should be placed at the unprotected bridge end.
 - b. Divided highway condition
 - (i) Three Type III barricades should be in place both to the right and to the left of the lanes approaching the bridge. The barricades should be placed at 50 ft (15 m) intervals, with the last barricade placed at the unprotected bridge end.
 - (ii) Barricades are not required on the lanes leaving the bridge.
 - c. In addition to the barricades at bridge ends, normal signing warning traffic that they are approaching a construction area should be in place.
 - d. It's our desire to have guardrail in place prior to the winter, however, these traffic controls are applicable to both active construction projects and projects that are held over the winter for completion in the next construction season.

- e. The above traffic controls are intended for use only during the period of time when construction activities require that a bridge end remain unprotected. The replacement of guardrail should be accomplished at the earliest possible date, to eliminate the unprotected bridge end condition.

400.05 INTERSTATE TRAFFIC CONTROL REQUIREMENTS

1. Median Crossings

The contractor is prohibited from using any established or other type median crossings on most four-lane divided highway projects unless a crossing is required and shown in the Traffic Control Plans.

2. Traffic Control Removal for Head-to-Head Projects

- a. To achieve uniform removal practices across the state, the following steps will be used to remove traffic control devices from head-to-head projects:

- Move diverted traffic stream back to its normal side of median.
- Place plastic drums in closed (passing) lane at intervals as prescribed in Manual on Uniform Traffic Control Devices.
- Remove all "Two Way Traffic" (W6-3) signs, leaving "Do Not Pass" (R4-1) signs in place.
- Remove double yellow lines with simultaneous removal of tubular markers, "Do Not Pass" signs, and plastic drums. At the same time yellow lines are removed, new white lane lines shall be placed. If lane line painting cannot be accomplished the same day as the double yellow lines are removed, plastic drums shall remain in place effectively closing the passing lane.
- Remove impact attenuator and all temporary barrier rail at upstream end.
- Remove any advance construction work zone signing in the direction towards oncoming traffic.

- b. The entire removal operation shall proceed upstream towards traffic. This will ensure that motorists will have two clear open lanes once they pass traffic control removal operations. Tubular markers shall not be removed in any area until the double yellow lines are removed, unless they are replaced with vertical panels or Type II barricades.

400.06 DEDUCTION FOR SIGNS

1. Use NDOT Form 502 "Construction Signs and Posts" to document signs supplied and returned by the contractor.
2. Itemize those signs not returned or damaged by the contractor in the Sign Deduction Computation Letter to the Construction Division, Finals Section. The itemized list, as described in the Finaling Manual should show the number of signs, sign number, message, sign size, cost per sign and total deduction. The list should also indicate which signs were damaged and which were not returned.
3. The Project Manager shall determine if the value of damaged or missing signs are to be deducted from the Contractor's payments. Assessment for broken,

damaged or unreturned signing materials is to be made for losses or damages which is due to the contractor's actions. The contractor will be assessed the total value of a sign and a salvage value will no longer be allowed for damaged signs.

4. The Project Manager will compute the assessment, create a Change Order, and enter it on a project estimate.

400.07 PRECONSTRUCTION CONFERENCE

1. The preconstruction conference is an excellent time to remind the contractor that many problems and delays can be avoided by the early submittal of their material list, shop drawings, and samples of all materials that require testing.
 - a. No materials can be incorporated into the work before first being reviewed by the appropriate Division.
 - b. If utility support is necessary, confirm the date that any utility work will be started and, if possible, the date completed.
 - c. Remind Contractors
 - (i) Preformed loops MUST be under the pavement, sawed loops are not an alternative (per Detector Plan).
 - (ii) Submit wire samples to Materials & Research early, get acceptance before installation. See [Materials Sampling Guide](#).
 - (iii) Order the poles early, lead time can be 11-15 weeks or longer.

400.08 SHOP DRAWINGS

1. SSHC Subsection 401.02 provides information on shop drawings and a materials list that is required of the contractor before they may incorporate any items into the project.
 - a. To assure uniform and effective operation of this requirement, the following procedures will be followed (SSHC 105.02):
 - (i) The Contractor is required to submit shop drawings to shop.drawings@Nebraska.gov. Construction Division sends the submittals to the appropriate Division for review and comments. All items will be checked for compliance with the plans and specifications. Construction Division notifies the Contractor and the Project Manager when review is complete.

400.09 ACCIDENT REPORTING

1. Prior to the start of construction, the District Construction Engineer (DCE) or their designee will notify in writing the appropriate Nebraska State Patrol office and local law enforcement office of the project location and scope. This correspondence should identify location, construction dates, and other pertinent construction project data including names and phone numbers of responsible contact persons from the contractor and District Office in case of a crash or other construction work zone issues.
 - a. If the Nebraska State Patrol determines the NDOT needs to make immediate repairs at a construction work zone crash site, the investigating officer will contact the appropriate District office. The DCE will evaluate the request and advise the PM as to what action to take. The

Project Manager will then inform the contractor's representative of needed corrective action. When construction work zone crash site does not require immediate corrective action by NDOT or contractor representatives, the investigating officer is to report the crash to the Project Manager within 12 hours.

- b. Whenever the Project Manager becomes aware of a traffic crash that occurred in a construction zone, the Attorney General suggests that the Project Manager immediately video record, photograph, and/or document the area to verify the position of signage, obstructions, traffic control devices, and other pertinent features. This information is to be retained according to the Department's records and retention policy.

2. Investigation Procedure

- a. For accidents resulting in property damage to NDOT facilities, the Project Manager shall identify repair costs and enter them into the DIRK system. A State Property Damage (SPD) case is often initiated by the SPD Coordinator in Traffic Engineering Division. Repair costs and supporting documentation should be entered into a temporary folder on the network where it can be accessed by other NDOT employees who may need to see it. (Folder name example for District 2: \\drfs\district 2\D-2\SPD's). When this information is complete, the SPD Coordinator, District Operations Manager, and District Administrative Assistant should all be notified by e-mail.
- b. If a State vehicle is involved in a crash, the driver is required to complete the Employee Accident form on the Human Resources section of OnBase® and the NDOT Form 41, Driver's Motor Vehicle Accident Report. These forms should be completed within 10 days of the crash. When completed, these forms are electronically sent to the SPD Coordinator, Human Resources, and the Fleet Manager.

3. Crash Notification Procedure

The NDOT or contractor staff should report construction work zone crashes to appropriate enforcement authorities (usually the Nebraska State Patrol for NDOT administered projects) and notify appropriate medical responders, if needed. Both the inspection supervisory staff and contractor supervisory staff should be notified promptly.

401.00 GENERAL INFORMATION

401.01 DESCRIPTION

401.02 MATERIAL REQUIREMENTS

- 1. All equipment and materials to be used on a project must be accepted before installation. Once accepted, there shall be no substitutions for any of the items without prior written request to, and written acceptance from, the appropriate Division subject matter expert. The inspector must make sure that only materials that have been accepted are used on the project.
- 2. The contractor is required to inform their supplier that all items supplied to the project must be suitably stamped, stenciled, tagged or otherwise marked to allow for easy identification with the descriptive markings,

brand names and catalog numbers shown on the materials list and shop drawings.

3. Specifications covering wood poles used on lighting projects is in *SSHC 1073*.

401.03 TESTS OF LIGHTING SYSTEMS

1. SSHC Subsection 401.03 requires the contractor to perform operating circuit and resistance test on the lighting system. The contractor shall submit the data from the testing to the Project Manager. The Project Manager shall file the data in OnBase®. The Project Manager will send documented results of these tests to the Lighting Engineer.

401.04 GROUNDING

401.05 GENERAL CONSTRUCTION REQUIREMENTS

1. The Contractor generally pays for the electrical power for a temporary lighting system. However, there may some instances that the Department will arrange and pay for the electrical power. If this is the case, the contract should indicate the specific details.

COMPLETION AND ACCEPTANCE OF THE PROJECT

1. Upon completion and acceptance of a lighting project, the Project Manager shall furnish the District Maintenance Superintendent (and the City or County, if applicable) with an electronic set of "as built" plans together with a set of shop drawings to facilitate maintenance of the lighting system. A link to the OnBase® location is acceptable for internal transmittals.

401.06 SECONDARY ELECTRICAL CONNECTIONS

402.00 WIRE AND CABLE IN CONDUIT

402.01 DESCRIPTION

402.02 MATERIAL REQUIREMENTS

402.03 CONSTRUCTION METHODS

402.04 METHOD OF MEASUREMENT

402.05 BASIS OF PAYMENT

403.00 DIRECT BURIED WIRE AND CABLE

403.01 DESCRIPTION

403.02 MATERIAL REQUIREMENTS

403.03 CONSTRUCTION METHODS

403.04 METHOD OF MEASUREMENT

403.05 BASIS OF PAYMENT

404.00 AERIAL CABLE

404.01 DESCRIPTION

404.02 MATERIAL REQUIREMENTS

404.03 CONSTRUCTION METHODS

404.04 METHOD OF MEASUREMENT

404.05 BASIS OF PAYMENT

405.00 CONDUIT

405.01 DESCRIPTION

405.02 MATERIAL REQUIREMENTS

405.03 CONSTRUCTION METHODS

405.04 METHOD OF MEASUREMENT

405.05 BASIS OF PAYMENT

406.00 PULL BOXES

406.01 DESCRIPTION

406.02 MATERIAL REQUIREMENTS

406.03 CONSTRUCTION METHODS

406.04 METHOD OF MEASUREMENT

406.05 BASIS OF PAYMENT

407.00 POLE AND TOWER FOUNDATIONS

407.01 DESCRIPTION

1. Pole foundation details will be shown in the plans. Tower foundations will usually be designed by the contractor.
2. Towers are installed using concrete foundations only. Poles are installed using either concrete or power foundations. Power foundations are allowed only when so indicated in the plans.
3. All excavations for concrete foundations shall be dry and free of loose dirt before the concrete is placed.
4. Foundations shall be installed before trenching for conduit and cable.
5. Backfill around foundations shall be compacted to optimum stiffness as defined by NDOT T 99.

407.02 MATERIAL REQUIREMENTS

407.03 CONSTRUCTION METHODS

1. Staking of Light Pole and Tower Foundations
The contractor is responsible for field verifying the foundation location and elevation of each lighting unit to determine that no conflicting or hazardous situation will exist when the pole or tower is erected. Any location or elevation that appears unreasonable or out of specifications as to projection above grade, will be brought to the Project Manager's attention. The Project Manager will decide any changes in location and/or elevation.

407.04 METHOD OF MEASUREMENT

407.05 BASIS OF PAYMENT

408.00 POLES AND TOWERS

408.01 DESCRIPTION

1. Conventional light poles are usually furnished by the Contractor complete with pole shaft, mast arm, luminaire, anchor bolts, foundation, and breakaway device (if required).
2. High mast towers are usually furnished by the Contractor complete with tower shaft, base plate, anchor bolts, lowering system with motor and foundation.
3. All poles and towers shall be plumb. Poles will be shimmed to stand plumb. Towers will be supported solely by anchor bolts and nuts. The nuts will be adjusted to plumb the tower.
4. All poles and towers will be grounded to a grounding rod(s) as shown in the plans.
5. All poles must have a handhole with cover attached.
6. Unless indicated otherwise, all poles required to breakaway on impact will have a frangible transformer base ("T base") as its breakaway device.
7. Poles and towers shall conform to the requirements of SSHC Section 1073.

408.02 MATERIAL REQUIREMENTS

408.03 CONSTRUCTION METHODS

408.04 METHOD OF MEASUREMENT

409.00 SIGNAL HEADS

409.01 DESCRIPTION

409.02 MATERIAL REQUIREMENTS

409.03 CONSTRUCTION METHODS

409.04 METHOD OF MEASUREMENT

409.05 BASIS OF PAYMENT

410.00 DETECTORS

410.01 DESCRIPTION

410.02 MATERIAL REQUIREMENTS

410.03 CONSTRUCTION METHODS

410.04 METHOD OF MEASUREMENT

410.05 BASIS OF PAYMENT

411.00 TRAFFIC SIGNAL CONTROLLER

411.01 DESCRIPTION

411.02 MATERIAL REQUIREMENTS

411.03 CONSTRUCTION METHODS

411.04 METHOD OF MEASUREMENT

411.05 BASIS OF PAYMENT

412.00 LUMINAIRES

412.01 DESCRIPTION

412.02 MATERIAL REQUIREMENTS

1. All luminaires must be on the [Nebraska Qualified Materials Vendors List](#) and have been specifically reviewed for compliance for use on the project in question by the contractor's submittal of shop drawings or catalog cuts.
2. Most luminaires are factory set to meet photometric requirements. Occasionally, in order to meet specifications, the position of the lamp socket in each luminaire must be adjusted by following a set of manufacturer's instructions accompanying each luminaire.

412.03 CONSTRUCTION METHODS

1. Unless indicated otherwise, all luminaires will be installed level in both horizontal axes.
2. Luminaires shall be installed to proper alignment and orientation with respect to the roadway.
3. Night inspection by the Project Manager (recommended) may determine the need for adjustments to the luminaires.

412.04 METHOD OF MEASUREMENT

412.05 BASIS OF PAYMENT

413.00 LIGHTING CONTROL CENTERS

413.01 DESCRIPTION

1. The location of the lighting control center as shown on the plans is approximate. Actual location will be as determined by the electric utility and the Project Manager.
2. Components comprising the various types of lighting control centers will be listed on the NDOT [Approved Products List](#) or will be specifically accepted for use on the project in question by the contractor's submittal of shop drawings or catalog cuts.

413.02 MATERIAL REQUIREMENTS

413.03 CONSTRUCTION METHODS

413.04 METHOD OF MEASUREMENT

413.05 BASIS OF PAYMENT

414.00 HIGH MAST LOWERING SYSTEMS

1. Unless indicated otherwise, all new lowering systems will be furnished with an internal power unit (each tower will have its own motor to raise or lower the light ring).
2. High mast lowering systems will be on the NDOT [Approved Products List](#) or specifically approved for the project in question by the contractor's submittal of shop drawings or catalog cuts.
3. A new lowering system will accompany each new tower.

4. Installation of a new high mast lowering system on an existing tower may require some modification to the tower. Modifications shall be made as detailed in the plans.

414.01 DESCRIPTION

414.02 MATERIAL REQUIREMENTS

414.03 CONSTRUCTION METHODS

414.04 METHOD OF MEASUREMENT

414.05 BASIS OF PAYMENT

415.00 MAINTENANCE OF PROJECT LIGHTING SYSTEM

415.01 DESCRIPTION

415.02 MATERIAL REQUIREMENTS

415.03 CONSTRUCTION METHODS

415.04 METHOD OF MEASUREMENT

415.05 BASIS OF PAYMENT

416.00 TEMPORARY LIGHTING SYSTEMS

1. There are a number of different types of temporary lighting systems.
2. All temporary lighting systems require the contractor to properly operate and maintain the lights daily from dusk to dawn through the construction period.
3. Materials for a temporary lighting system may be State or contractor furnished as indicated in the plans.
4. Usually, the contractor will be responsible for providing the electrical energy required to energize the crossover type temporary lighting system.
5. An equipment grounding conductor is usually not required in a temporary lighting system. In some service areas, however, the utility may require that an equipment ground be used.
6. When the temporary lighting units are no longer required, the contractor will, in strict conformance with the project requirements, remove, prepare and deliver the units to the designated storage area.

416.01 DESCRIPTION

416.02 MATERIAL REQUIREMENTS

416.03 CONSTRUCTION METHODS

416.04 METHOD OF MEASUREMENT

416.05 BASIS OF PAYMENT

417.00 HIGHWAY SIGNS

417.01 DESCRIPTION

417.02 MATERIAL REQUIREMENTS

417.03 CONSTRUCTION METHODS

417.04	METHOD OF MEASUREMENT
417.05	BASIS OF PAYMENT
418.00	OVERHEAD SIGN SUPPORTS
418.01	DESCRIPTION
418.02	MATERIAL REQUIREMENTS
418.03	CONSTRUCTION METHODS
418.04	METHOD OF MEASUREMENT
418.05	BASIS OF PAYMENT
419.00	TRAFFIC CONTROL MANAGEMENT AND SURVEILLANCE
419.01	DESCRIPTION
419.02	CONSTRUCTION METHODS
419.03	METHOD OF MEASUREMENT
419.04	BASIS OF PAYMENT
420.00	DELINEATORS
420.01	DESCRIPTION
420.02	MATERIAL REQUIREMENTS
420.03	CONSTRUCTION METHODS
420.04	METHOD OF MEASUREMENT
420.05	BASIS OF PAYMENT
421.00	REMOVING AND RESETTING DELINEATORS
421.01	DESCRIPTION
421.02	CONSTRUCTION METHODS
421.03	METHOD OF MEASUREMENT
421.04	BASIS OF PAYMENT

422.00 TEMPORARY TRAFFIC CONTROL SIGNS AND DEVICES

422.01 DESCRIPTION

422.02 MATERIAL REQUIREMENTS

1. SIGN MOUNTING DEVICES

- a. Signs for traffic control zones that are in place no longer than three days may be mounted on a temporary sign support (Temporary Sign Day). Signs that are in place longer than three days are permanent signs that shall be post mounted (Sign Day). Temporary signs may either be post mounted or temporarily mounted. Signs mounted on Type III Barricades may be in place longer than three days (Barricade Sign Day).
- b. In urban areas, signs that require post mounting may be skid mounted at the post mounting heights required in the MUTCD provided that skid mounting devices are of a breakaway design.

422.03 CONSTRUCTION METHODS

1. FLAGGERS & PILOT CARS

- a. The Department has made the Flagger Certificate quiz and the Flagger Training materials available through LTAP <https://ltap.unl.edu/online-flagger-certification>
- b. The flagger on a construction project is the first line player in communicating with the driving public. It is imperative that the flagger be able to read and speak English clearly with the drivers in a work zone. The contractor is responsible for insuring that anyone performing flagging can meet these requirements.

2. INERTIAL BARRIER SYSTEMS

- a. A Type I object marker must be placed directly on the front of the first module, either by adhesive or rivet, etc. The marker is not to be placed on a separate post in front of the module. The presence of a post in front of the system could affect the crash characteristics of the inertial barrier system.

3. BARRICADES/PLASTIC DRUMS

- a. Reflectivity testing should be performed in accordance with the [Materials Sampling Guide](#).

4. PORTABLE DYNAMIC MESSAGE SIGN GUIDELINES

- a. The Department owns Portable Dynamic Message Signs (PDMS) stored at various locations statewide. These PDMS units are intended to be used for incident management traffic control for major interstate reconstruction, emergency response, temporary road closures for bridge beam replacement, temporary utility crossing requiring road closure, and for other emergency related road closings.
- b. PDMS units used for incident management traffic control should have the word message approved by the District/State Operations Center, whichever is applicable, since the appropriate message will vary from project to project.

- c. Proposed word messages should be limited to a maximum of 2 panels and usually eight characters per line, with three lines per panel.
- d. PDMS units used for project purposes will be under control of the appropriate maintenance office. Repair costs for PDMS units used for project related incident management can be charged against project funds using the appropriate documentation.

422.04 METHOD OF MEASUREMENT

- 1. If an item for flaggers and pilot cars is included in the bid proposal, days are estimated to determine the low bidder. These bid items often overrun due to contractors using multiple work crews at different locations within the same project.
- 2. The inspector will count the number of days each flagger (or pilot car) was used. Every flagger and pilot car used and approved by the PM as part of a preplanned work operation is to be paid if their usage is required as a part of required traffic control. Flaggers used solely as a benefit to contractor to help control their own equipment are not to be counted for payment.

422.05 BASIS OF PAYMENT

423.00 PERMANENT PAVEMENT MARKING

423.01 DESCRIPTION

423.02 MATERIAL REQUIREMENTS

423.03 CONSTRUCTION METHODS

- 1. Pavement moisture can be measured by placing and holding a two square foot piece of clear plastic on the existing pavement for a period of 15 to 20 minutes. Remove and hold the plastic in a vertical position. If water drips from the underside of the plastic sheet, the pavement has excess moisture.

423.04 METHOD OF MEASUREMENT

423.05 BASIS OF PAYMENT

424.00 TEMPORARY PAVEMENT MARKING

424.01 DESCRIPTION

424.02 EQUIPMENT

424.03 MATERIAL REQUIREMENTS

424.04 CONSTRUCTION METHODS

- 1. REMOVAL OF TEMPORARY PAVEMENT MARKINGS
 - a. Temporary pavement markings are necessary for most construction projects. Typical locations include temporary roads, shifts, phased construction, etc. When temporary pavement markings are placed, they will eventually be removed as part of the project.
 - b. Removal depends on the type of pavement marking material placed and type of surface to which it is attached (new, old, ACC, or PCC).
 - c. Each temporary pavement marking material has its own removal characteristics.

- d. All residue and/or debris shall be removed from the pavement surface when removing temporary pavement marking materials. Any removal process shall not cause damage to the final pavement surface.
 - e. Upon completion of the project, any temporary pavement marking which is not intended to remain in place must be removed. This includes stop bars, lane shifts, and any temporary markings left on travel lanes or shoulders.
2. Raised Pavement Markers
- a. Interstate or other complex project traffic control plans may include the use of raised pavement markers to supplement the temporary pavement markings for the project. Raised pavement markers are used in lane shifts or at crossover location to enhance visibility of correct travel path through these areas. Raised pavement markers are very effective if they stay in the correct location on pavement surface.
 - b. Off-tracking rear wheels on semi-trailers often dislodge raised pavement markers from the pavement surface. It is permissible to offset the location of the raised pavement markers up to 1 ft. (300 mm) laterally away from the temporary pavement marking line to avoid the off-tracking rear trailer wheels.

424.05 METHOD OF MEASUREMENT

424.06 BASIS OF PAYMENT

1. Because roadway lighting usually makes up only a small portion of a projects total cost, it is many times thought of as insignificant and not requiring much attention. Many benefits in the form of public safety, security, convenience and drivers comfort, however, are derived from a quality lighting job. This makes the lighting inspector's job of checking out and inspecting all aspects of the lighting construction, one of utmost importance.

DIVISION 500

BITUMINOUS PAVEMENT

**DIVISION 500
BITUMINOUS PAVEMENT**

500.00 ASPHALT PAVEMENT CHECKLIST

SSHC References: Section 501 General Requirements

- 502 Asphalt Concrete Pavement Smoothness*
- 503 Asphalt Concrete Pavement*
- 504 Tack Coat*
- 505 Asphalt Concrete Curb*
- 510 Cold Milling*
- 1028 Asphalt Superpave Concrete*
- 1029 Performance Graded Binder*
- 1033 Aggregates*

Inspection Crew: Plant Inspector
Laydown Inspector

Inspection Equipment: Non-Nuclear Density Instrument (PQI) – Laydown
Thickness Ruler – Laydown
10 foot (3 m) Straightedge – Laydown
Rolling Straightedge (Bump Buggie) – Laydown
4 ft. (1.3 m) Carpenter Level – Laydown
Thermometer (Surface) – Plant & Laydown
Cleaning Solvent – Plant & Laydown
Gravel Sampling Bags – Plant & Laydown
Tack Oil Sample Containers – Plant
Cardboard Shipping Boxes – Plant
Insulated Container – Plant
Performance Graded Binder Sample Cans – Plant

General Inspection Checklist:

1. Review all Plans, Specifications, Road Standards, Materials & Research Manuals/guidance and the *Construction Manual*. Prepare field record spreadsheets.
2. Check project quantities to ensure accuracy.
3. Are asphalt concrete mix designs approved?
4. Obtain necessary inspection equipment and review sampling and testing procedures and frequencies.
5. Locate or mark 'passing' and 'no passing' zones prior to construction.

6. Locate and reference fixtures to be adjusted prior to placing final layer. (ie., guardrail locations, mailboxes, manholes, valve boxes, etc.).
7. Does equipment meet requirement of *SSHC Subsection 503*: Hauling Equipment, Tampers/Vibratory Plates, Rollers, Material Surge Bins, Weighing Equipment, Distributors, Spreaders, Brooms, Trenchers, Pickup Machines, Notched Wedge Equipment, Beveled Edge Shoe, Curb Forming Equipment, Pavers
8. Check traffic control, work zone length, flaggers, signing, pilot vehicle operations.
9. Are tarps or insulated truck boxes required?
10. Check for improper use of diesel in lieu of approved release compounds. (*SSHC Subsections 501.02*)
11. Think safety! Use proper equipment, wear protective clothing, and be aware of traffic and Contractors' operations.

Asphalt Plant Inspection Checklist:

1. Get preconstruction samples of aggregates and ship to Materials & Research Lab, as per NDOT [Materials Sampling Guide](#).
2. Get Random Sampling Schedule from Materials & Research alert Contractor just prior to when and where samples are required. Take custody of asphalt samples.
3. Obtain and ship required performance graded binder samples and emulsion samples to NDOT Materials & Research Asphalt Lab.
4. Keep records on asphalt temperatures at plant; should not exceed 350°F (177°C).
5. Make sure loader operator does not contaminate aggregates.
6. Are trucks properly loaded and within legal weight limits?

Laydown Inspection Checklist:

Subgrade

1. Has grade and alignment staking been completed and checked?
2. Is subgrade according to plan, stable, and corrected tolerance (*SSHC Section 302*)?
3. Are any string line offsets referenced to permanent stakes?
4. Is gradeline string, when required, accurately set and maintained? (*SSHC Subsection 503.03*)
5. Check paver screed for proper crown and excessive wear. Are automatic grade and slope controls operational? (*SSHC Subsection 503.03*)
6. Determine if correct type and rate of tack coat material is being applied. (*SSHC Section 504.03*)
7. Check distributor spray bar height and nozzle angle against manufacturer's recommendations to achieve uniform tack coat. Is the distributor tank calibrated? (*SSHC Subsection 501.02*)

8. Before laydown, the existing surface shall be clean of foreign material such as millings latencies.
9. Were all vertical faces tack coated?
10. Excessive asphalt spilled while loading finishing machine must be picked-up.
11. Check each truck load of mix for proper scale ticket. Document the placement location on the ticket, if other than roadway lifts. (ie., Drive/Intersection, Shoulder, Patching, etc.) (*SSHC Section 503.05*)
12. Is mix being placed at proper temperature range? (*SSHC Subsection 503.04*) Check surface temperature. (*SSHC Table 503.03*) Keep record on temperatures.
13. Are proper lift thicknesses being constructed for temperatures and density requirements? (*SSHC Subsection 503.04*)
14. Perform proper tonnage checks to verify thickness and notify the Contractor as soon as they are out of limits.
15. Check width, depth, and cross-slope, for conformance to the typical section as per plan.
16. Ensure the Contractor is checking the frequency and amplitude of vibratory rollers in accordance with manufacturer's recommendations.
17. Is the established rolling pattern being maintained and documented? (*SSHC Subsection 503.04*) Are asphalt concrete properties in the test strip determined to be acceptable prior to proceeding?
18. Check smoothness irregularities with 10 foot (3 m) straightedge in roadway sections where profilometer smoothness (*SSHC Subsection 503.04*) is not required.
19. Traffic will not be exposed to bumps greater than 2 inches (50 mm). Such bumps must be protected by wedges not steeper than 1 inch (25mm) in 3 feet (1m).
20. Is paver hopper near full at all times? (*SSHC Subsection 503.04*) Check flow gates and augers. Paver wings should not be dumped and wasted at the end of each day.
21. Do drop-offs and beveled edges comply with plan details?
22. Are proper number of trucks available for continuous paving? Make notes if this becomes a problem to understand if it causes problems with segregation, smoothness or overall quality control later.
23. Compare paver speed to plant output to eliminate paver stopping, which can create bumps, dips or segregation. (*SSHC Subsection 503.04*) Consistent speed results in more consistent pavement properties.
24. Check and record yield based on tons (megagrams) of mix required compared to tons (megagrams) of mix used. (Recommend 2-hour intervals)
25. Is surface texture uniform, dense, and free from irregularities, tearing, steel roller marks, check cracks, solvent spots, and segregation? (*SSHC Subsection 503.04*)
26. Are temporary runouts and fillets in compliance with applicable standards?

27. Watch joints to make sure they close tightly and attain proper density. Tack vertical face of joints.
28. Are transverse and longitudinal joints constructed properly?
(SSHHC Subsection 503.04)
29. Avoid longitudinal joints in the driving lanes wheel path. Paver must be able to cover the entire lane in one pass.
30. Mark original and any re-cut core locations, according to 'random schedule' and observe core sampling. Ensure all core holes are properly filled and asphalt sufficiently compacted.
31. Do shoulder rumble strips conform to the Plan details? Check indentation depth and alignment of strip.

Safety Concerns:

1. Flaggers must be certified and use follow established procedures. Note violations and actions used to correct deficiencies.
2. Contractors' vehicles traveling into or out of the construction zone are subject to flaggers and pilot vehicle direction.
3. Be alert to traffic, Contractor's equipment, and other hazards. Wear proper protective equipment.
4. Be aware and follow applicable worker safety regulations that apply to each work area and other applicable safety requirements.

NDOT Tests: See NDOT [Standard Methods of Tests](#)

1. AASHTO T265; NDOT T205 & T2835 (Soil Moisture & Density/Deflection)
2. NDOT T2, T27 & T506; AASHTO T248, T255 & T11 (Aggregate Sampling, Splitting, Moisture, and Gradations)
3. Asphalt density testing in accordance with Subsection 1028.03 and Section 1081.

Sampling Requirement/Freq.: SSHHC Subsection 1028.02 NDOT [Material Sampling Guide](#)

1. Emulsified Asphalt
 - a. Field-Diluted: Unless diluted under engineer supervision, 1-qt. plastic container from each tank car or truckload following dilution.
 - b. Supplier-Diluted & Undiluted: When requested by NDOT central lab, 1-qt. plastic container from tank car or truckload following receipt at project.
2. Performance Graded Binder
 - a. 1- 2 qt. can per liquid binder lot [200 tons (181 Mg)], or portion thereof to NDOT central lab.
3. Hydrated Lime or Type S Lime
 - a. Supplier's certification stating its compliance to the specification.

4. Recycled Asphalt Shingles
 - a. 1- 5lb. sample representing the lot submitted to NDOT central lab for review.
5. Asphalt Concrete
 - a. Density Cores: See specifications, supplemental specifications and/or project special provisions.
 - b. Mix Properties: Ensure a sample for each 500 (454 Mg) or 1,000 ton (907 Mg) sub-lot is retained by the Contractor for possible branch lab testing. In addition, for SPH & SPR Asphaltic Concretes, a sample of six TSR testing specimens from the first lot of field production and randomly selected lots thereafter are required.
6. Asphaltic Oils
 - a. When requested by NDOT central lab, 1-2 qt. can from a tank car or truckload following receipt at project.

Inspector's Field Records & Forms:

1. SiteManager Daily Work Report
2. SiteManager Sampling and Testing
3. Asphalt Laydown Record' MS Excel Workbook
4. Asphalt Plant Book' MS Excel Workbook
5. Profilograph Workbook' MS Excel Spreadsheet
6. Smoothness Incentive-Disincentive – Asphalt' MS Excel Workbook
7. Asphalt Quality Calculator' MS Excel Workbook
8. Intersection & Driveway Computations' MS Excel Workbook
9. Microsurfacing with Automated System' MS Excel Spreadsheet
10. Pavement Marking' MS Excel Spreadsheet
11. Miscellaneous FCAC MS Excel Pay Item Spreadsheets
12. NDOT471 – 'Log of Work Area Speed Zones' MS Excel Spreadsheet
13. Field Office Compliance' MS Word Form
14. Noncompliance Notice' MS Word Form
15. Miscellaneous FCAC MS Word Forms

501.00 GENERAL REQUIREMENTS

501.01 GENERAL

1. Bituminous surfacing includes coats, seals or asphaltic concrete layers.
2. Before placing bituminous surfacing, the existing surface must be thoroughly cleaned to ensure proper bonding.
3. Any damage caused by the Contractor will be repaired or replaced at their expense.

501.02 EQUIPMENT

1. Equipment must be designed and properly calibrated for the specific job at hand, as per the specifications, and care must be taken not to mar, rut or contaminate the bituminous surfacing.

502.00 ASPHALT CONCRETE PAVEMENT SMOOTHNESS

502.01 GENERAL

1. The traveling public judges an overall project by the smoothness and appearance of surface courses and pavements. The quality of the construction will determine the serviceability, durability, strength, and riding quality of the project.
2. Surface smoothness testing is to be performed by the Contractor using both a 10 ft. (3 m) straightedge and a profilograph. The State must verify the Contractor's profilograph.

502.02 EQUIPMENT

1. The Contractor is responsible for providing the profilograph. Equipment used for smoothness testing shall be a computerized non-contact inertial pavement profiler and a 10 foot (3 m) straightedge. Ensure that the tire pressure on the profilograph is maintained at the proper level.
2. Pavement surfaces to be tested for smoothness with the profiler are identified in Plans or Special Provisions.
3. For all projects, the 10-foot straightedge method may be used to identify bumps 1/8" and greater.
4. Surface correction shall be made as per *SSHC Subsections 502.02 & 502.06 and Construction Manual 502.06*.

502.03 CERTIFICATION AND INDEPENDENT ASSURANCE TESTING

1. Both the operator and the non-contact profiler must be State certified.
2. The operator must be certified at least every 5 years.
3. A dated and signed decal should be placed on the profiler certifying its acceptability for use on Nebraska Department of Transportation projects. This certification expires one year after its issue date.

502.04 PROFILOGRAPH TEST PROCEDURES

1. Use the FCAC MS Excel Spreadsheet "Profilograph Add-In" program to create "Mile Sheets" for the Contractor identifying all required test sections.
2. Provide ample notification to the Materials & Research Quality Assurance Manager for scheduling timely smoothness verification testing.
3. The intent is to check the pavement for surface smoothness as soon as possible after final rolling. The profilograph must be run no later than the next working day following placement.
4. The smoothness measurements must be performed in both wheel paths of all driving lanes.
5. Since so much money can be involved, it is very important that you make an effort to have an inspector present while the smoothness testing is being

performed. Make it very clear to the Contractors that they are to provide adequate notice of any smoothness testing so that inspection can be arranged. DO NOT accept a profilogram if you were not notified about a test and did not have an opportunity to provide inspection.

6. Make sure that the profilograph operator maintains a true course while advancing the machine down the road. Weaving, even if not done in an attempt to avoid a rough area, should not be permitted.
7. Immediately following each test, the profiler operator and the Engineer, both, sign the printed report and graph chart "trace" for authenticity verification. The trace produced by the profilograph is to be evaluated by the Contractor and then given to the State for review and retention immediately following each test.
8. If pavement smoothness is outside specification limits, it is most imperative that the Contractor determine the cause and it be corrected to ensure a smooth pavement meeting specifications.
9. If grinding is necessary, observe roadway temperatures do not become excessive. If temperatures become too hot, the equipment may pull aggregates right out of the pavement. Stop operations until the pavement has sufficiently cooled down.

502.05 EVALUATION

1. The Contractor's pavement profiler record, analyze, print and electronically transfer the test data and the Contractor must provide the Engineer a printed trace and summary providing the IRI values and identifying bumps and dips for each test section.

502.06 PAVEMENT SURFACE CORRECTION

1. All bumps, dips and test sections with an IRI exceeding 96 in/mi shall be corrected by diamond grinding.

502.07 TRAFFIC CONTROL

1. The Contractor is responsible for all traffic control associated with smoothness testing and corrective work at no cost to the State.

502.08 METHOD OF MEASUREMENT

1. The FCAC Workbook, "Smoothness Incentive - Disincentive - Asphalt", should be used to make the following incentive or disincentive computations.
2. The mass of asphaltic concrete to which the incentive/disincentive payment is to be applied shall be determined by calculating the asphalt placed in the top layer within those areas defined by the width of the driving lane (or lanes) shown on the plans and the length (or lengths) of the project subject to profiling, except that:
 - a. When a narrow shoulder is required to be laid with the adjacent lane (inside shoulder on Interstate, for example), the full lane and shoulder width shall be used.
 - b. When it is impractical to lay additional width except while laying the top lift through the laydown machine 28 foot (8.5 m) roadway, for example), the full width shall be used.

3. The thickness of the top layer used to determine the mass shall be either:
 - a. The nominal thickness shown on the plans (if shown), or
 - b. The lesser of the actual, average thickness laid or the maximum thickness allowed by the Specifications.

The mass per unit volume used to determine the total mass shall be as follows:

<u>Mass Per Unit Volume</u>	<u>Mix Type</u>
126 lb/ft ³ (2018 kg/m ³)	OGFCCRMM
135 lb/ft ³ (2162 kg/m ³)	GGCRM
139 lb/ft ³ (2227 kg/m ³)	GGCRMLV
143 lb/ft ³ (2291 kg/m ³)	SPH; SP3; SP4 Special(0.375); SP4 Special(0.5); SP4(0.5); SP5(0.5);
144 lb/ft ³ (2307 kg/m ³)	SP0, SP1, SP2
145 lb/ft ³ (2323 kg/m ³)	SLX; SPR; SPL; SP4(0.375); SP5(0.375); SRM
146 lb/ft ³ (2339 kg/m ³)	SPS

4. The mass of performance graded binder to which the incentive/disincentive payment is to be applied shall be determined by the formula:

$$[\text{Concrete mix (mass)}] (\text{Percent of Performance Graded Binder}) = \text{Mass Performance Graded Binder}$$
5. Unless revised by the Materials and Research Division, the percentage of performance graded binder to be added as shown on the Job Mix Formula (JMF) shall be used to compute the smoothness incentive/disincentive for performance graded binder.
6. When calculating the pay factor for smoothness (PF), round to the nearest hundredth.
7. The unit price for the incentives shall be calculated by the formula and entered as a "positive" dollar amount:

$$\frac{(\text{Pay Factor} - 100.00)}{100} \times \text{Contract Unit Price}$$
8. The unit price for the disincentives shall be calculated by the formula and entered as a "negative" dollar amount:

$$\frac{(100.00 - \text{Pay Factor})}{100} \times \text{Contract Unit Price}$$
9. Be reminded that the incentive/disincentives calculations are based on the bid prices for the asphaltic concrete and PG binder. Penalties or deductions determined on the Density Pay Factor summary do not enter into these calculations.
10. When making the contract modifications to place these items into the system, show "Spec. Prov." as the authority for the modification. It is also requested that you show pay factor on the same line; e.g., "Spec. Prov. 101.26%".

502.09 BASIS OF PAYMENT

1. The following standard items and standard item numbers have been established to provide incentive/disincentive payment for bumps and smoothness in conjunction with Superpave quality as computed from the 'Asphalt Quality' MS Excel Workbook:

9300.32	Incentive Payment for <i>Asphalt Quality</i>	LS
9300.34	Disincentive Payment for <i>Asphalt Quality</i>	LS

503.00 ASPHALT PAVEMENT

503.01 DESCRIPTION

1. This Subsection explains processes involved in the production and placement of asphaltic concrete and the inspection procedures required to assure quality is maintained.

503.02 MATERIAL REQUIREMENTS

1. Field Tests and Certification of Materials
 - a. Sampling and testing are required to determine whether the quality of materials and construction are in reasonably close conformance with the plans and Specifications.
 - b. Project inspectors shall monitor all materials received on a project before they are incorporated into work. Inspectors shall determine that proper inspection reports or certifications are on hand, and that no unusual alterations in characteristics of materials due to handling or other causes occurred.
 - c. Schedules in the [Materials Sampling Guide](#) contain various field tests and sampling frequencies for asphalt materials and mixtures.
 - d. The QA/QC program was started in 1993 with the goal of improving the overall quality of asphalt produced and giving the Contractor the responsibility for mix design, sampling, testing, and making mix adjustments. In other words, Contractors were given responsibility for the product they produce. If needed, most administrative questions involving asphalt paving projects can be answered by referring to the Flexible Pavement Engineer.
2. Asphalt Materials
 - a. Acceptance of asphalt materials will be on the basis of test results or certification from an approved source. Formal approval of a source is to be issued by the Materials and Research Engineer.
 - b. Each shipment invoice covering asphalt materials delivered to a project shall have a signed certification statement as to type and grade, specific gravity or mass per liter, load quantity, batch number or other identification, and project number. A copy of this invoice shall be furnished to Project Manager or project inspector for review and filing.
 - c. The Project Manager must have documentation of the following:
 - (i) Performance Graded Binder

- (ii) Aggregates
 - (iii) Asphaltic mix taken behind the paving machine but in front of the rolling operation.
 - (iv) Asphalt in-place density.
 - d. Performance graded binder suppliers are grouped into two categories (levels).
 - (i) Level-1 suppliers are certified suppliers who have submitted documentation to the Department and as part of the certification process, the Department has inspected the supplier's plant.
 - (ii) Level-2 suppliers are approved suppliers that are not certified.
 - (iii) The difference between being level-1 and 2 is that level-1 suppliers are only verified every other day while level-2 suppliers must be verified each day. This verification is between the lab and the supplier and the PM is not involved.
 - e. Hot-In-Place asphalt work may require support from the lab. Make sure you notify the lab at least 2-3 days in advance so they can plan to be on-site when the work begins.
 - f. Density of the in-place mix can be tested with the nuclear density gauge or by taking cores and measuring the density of the cores. The Engineer will provide locations for tests and re-tests from the Materials & Research generated "Random Sampling Schedule"; this schedule is to be kept confidential and in the possession of the NDOT plant inspector at all times.
- 3. Aggregates
 - a. Aggregate gradation and characteristics are covered in detail by *SSHC Section 1033*. Acceptance for quality will be based on source monitoring and test results on assurance or project samples.
- 4. Responsibility And Documenting Asphalt Mixture Proportioning Changes
 - a. SSHC Section 1028 explains how asphalt mixtures will be controlled. It establishes job mix criteria and corrective procedures to be followed when mixture characteristics are changed from the job mix formula during mix production.
 - b. The Contractor has sole responsibility for making mix changes; however, the Materials & Research Engineer and Project Manager must be kept informed and involved in these changes. Mix change decisions must be an interactive process between the Contractor and the Department.
 - c. The Project Manager must also ensure that required changes are implemented by the Contractor as soon as possible when mixture characteristics fall outside *SSHC Section 1028* limits. On each working day, the Project Manager shall determine if work for previous working day was within *SSHC* specifications. If not, immediately consult with the Contractor and find out what corrective actions have been or will be taken. Contact the Flexible Pavement Engineer if additional guidance is needed.

5. Adjusting Performance Graded Binder Contents
 - a. Job mix control is the Contractor's responsibility. The Contractor is responsible for sampling, testing, reporting results, and making appropriate mix changes.
 - b. When test results for air voids of plant produced mix are outside the limits given in *SSHC Section 1028*, the Contractor needs to contact the Project Manager and initiate changes in the asphalt mixture. The Contractor's first efforts at corrective action should be to adjust the aggregate percentages as needed. The adjusting of the performance graded binder content should not be the first step because when performance graded binder content changes are considered to adjust air voids, caution must be used to assure that adequate film thickness is maintained. Reductions in performance graded binder content must not go below the minimum allowable performance graded binder content as calculated in *SSHC Section 1028*.
 - c. Changes to the mix design will prompt the Materials & Research to issue a revised job mix formula (JMF).
6. Documenting Corrective Action for Noncomplying Air Voids Test on Specimens Taken from Constructed Pavement
 - a. The Contractor is required to report tests for field air voids on mix samples from behind the paver on the "NDOT Superpave Software" MS Excel workbook.
 - b. If conflicts develop between the Contractor's and the NDOT's field voids, then together the Contractor and the Department should concentrate on achieving proper voids and resolve the conflicts. When noncomplying tests for air voids in specimens taken from constructed pavement occur, the Project Manager will notify the NDOT Materials and Research Asphalt Lab if it cannot be corrected. The Contractor will document noncompliance in the "NDOT Superpave Software" MS Excel workbook containing the noncomplying test results.
 - c. In response, the Contractor will inform the NDOT Branch Lab and Project Manager as to what changes in mix proportions, if any, should be made. The Contractor will furnish project personnel written documentation for the decision or action taken.
7. Adjusting Aggregate Proportions
 - a. Contractor must occasionally adjust aggregate proportions to consistently comply with the contract provisions and to correct calibration errors.
 - b. Contractors shall initiate and make changes necessary to ensure compliance to *SSHC Sections 1028 and 1033*. The Contractor shall document all changes being made.
 - c. Proportion changes which exceed provisions of the contract may require a new mix design unless waived by Project Manager.
 - d. Project Managers and inspectors need to be familiar with the Contractor's QC program because it should provide many of the guidelines needed for making mix change decisions. Project Managers are expected to

- Research if needed prior to, during, and after the Contractor makes decisions concerning mix proportion changes.
- e. Proportion changes shall be documented by the Contractor in the “NDOT Superpave Software” MS Excel workbook.
8. Filler-Bitumen Ratio
- a. SSHC Section 1028 defines the filler-bitumen ratio. Filler-bitumen is the ratio of material passing the #200 (75 μ m) sieve divided by percent of performance graded binder in the mix (i.e., tank sticks, etc.).
- b. The Plant Inspector should determine if and by how much a Contractor proportion change will affect the filler-bitumen ratio. If it is necessary, contact NDOT Materials & Research Asphalt Lab for guidance.
9. Asphalt Report Forms
- a. Construction inspection personnel are responsible for monitoring/assisting in field sampling and testing in accordance with requirements of SSHC and those outlined in the [Materials Sampling Guide](#). Forms are supplied for reporting test results, submitting samples, and as inspector work sheets.
- b. Under the certified plant inspector program and quality assurance program, specific sampling and testing will be done by the Contractor's representative per SSHC Section 1028 and the [Materials Sampling Guide](#). Plant inspectors and the Contractor's quality control technicians must also be familiar with all applicable specification requirements including the sampling and testing procedures.
10. Form Identification and Use
- a. Daily plant operation, job control testing, and material placement for asphalt production are recorded in the “Daily Asphalt Plant Record” and “Daily Asphalt Laydown Record” MS Excel workbooks and SiteManager. Copies of the Contractor's reports shall be sent to Materials & Research Engineer, Branch Lab Quality Assurance Manager and the Project Manager.
- b. A SiteManager generated sample ID form must accompany all samples submitted to Materials & Research or the branch materials laboratories.
- c. A mix design letter from the Contractor and approved by the Flexible Pavement Engineer is used to define aggregate components of asphalt, to identify material sources, gradation, production limits, and proportions for the asphalt mix designs.
- d. The Contractor will use the “NDOT Superpave Software” MS Excel workbook for plotting all moving average data, various temperatures and other graphed data.
- e. Although submission of a daily report is not required, it is necessary that each day's production information be recorded in the “Daily Asphalt Plant Record” and “Daily Laydown Record” Excel Workbooks and SiteManager. It is very important that the daily placement be identified by station location, side, lift, lift thickness, and material characteristics. This type of

information becomes necessary in case of deductions or answering inquiries regarding any traffic accident occurring on the project.

503.03 EQUIPMENT

1. Asphalt Plants

Project Managers are responsible for verification, inspection and/or monitoring at asphalt plants. They should assure themselves that the Contractor's QC inspectors are qualified and have been informed about their specific duties. This should include, but not be limited to, frequency of tests, information to be recorded, and samples to be obtained and held for use by Materials & Research and Branch laboratories.

The Contractor is responsible for all plant inspections. Their duties include constant checks of stockpile handling, equipment settings, mixture appearance, and supervision of scale inspectors and assistant plant inspectors.

The Contractor shall furnish and be responsible for certified plant inspection in accord with *SSHC Section 1028*. All asphalt production, including patching, will be covered by certified plant inspection unless otherwise excluded by contract documents or when 500 tons (450 Mg) or less of asphalt are used on project. Plant monitor requirements are identified in *SSHC Section 1028*.

The Contractor's QC lab technician is responsible for meeting all sampling, testing, and documentation requirements as set forth by the current contract. For some Contractors, this person may also be responsible for certified plant QC inspector duties as well. The QC technician should maintain good communication with the NDOT inspector, Branch Lab Quality Assurance Manager and Materials & Research personnel especially on test results and mix changes.

2. SPECIAL EQUIPMENT

a. Material Transfer Vehicle

- (i) The Material Transfer Vehicle (MTV) provides mix surge capacity to allow more constant paver speed and efficient paving operations. It operates in front of or beside the paver and accepts loads of hot asphalt from delivery trucks. It provides a large surge storage bin that can continually feed the paver hopper.
- (ii) The Bridge Division will verify each bridge capability on a case-by-case basis with the following limitations.
- (iii) Any damage caused to existing surfacing shall be repaired at the Contractor's expense.
- (iv) These limitations apply for use of vehicle in a construction work zone. Contractors must obtain any necessary permits for moving this vehicle to and from project on an open highway. Do not allow Contractor to operate this equipment unless the lane in which the MTV operates is closed to traffic or is controlled by flaggers.

- b. Mat Smoothness Machine
- (i) The mat smoothness machine is an asphalt material receiving hopper and elevator that deposits hot asphalt into paver hopper. Use of this equipment allows for a more consistent paver operation by providing some surge capacity for the paver, only on a much smaller scale than the MTV.
 - (ii) Mass restrictions are not a concern with this piece of equipment.
 - (iii) Advantages for use of material transfer vehicles and mat smoothness machines include:
 - Smoother pavements due to elimination of trucks backing into paver and ability to provide a more uniform operation speed.
 - Reduction in potential for truckload interval segregation due to amount of mixing the material receives going through this equipment.
 - (iv) Even with the MTV or mat smoothness machine, the paver hopper should be kept relatively full at all times. If the hopper is allowed to drawn down too far, coarse aggregate collected in sides of paver hopper might be drawn down and create streaks of segregation in mat surface.
- c. Windrow Pick-up Equipment
- (i) With this process, hot asphalt is deposited in a windrow onto pavement surface using bottom dump trailers. A windrow pick-up elevator deposits the material into paver hopper. Again, primary advantages are Contractor efficiency and uniform speed of operation.
 - (ii) Segregation has occurred on several projects on which this equipment was used. Truckload and longitudinal strip type segregation are potential problems with this equipment.
 - (iii) All material deposited onto roadway must be picked up and put through the paver. Material left on roadway will cause surface problems following completion of project.

503.04 CONSTRUCTION METHODS

1. Unstable Subgrades And Subbases
- a. See *SSHC Sections 302, 303, and 305* for subgrade requirements.
 - b. Whenever trucks or other paving equipment cause rutting of the subbase or subgrade in asphalt placement areas, inspectors shall immediately stop construction. Construction shall not be allowed to resume until distorted subgrade or subbase is repaired (*SSHC Subsections 105.03 and 105.10*).

2. Locating Unstable Areas
 - a. Contractors and inspectors should locate by proof rolling, any questionable unstable areas in advance to avoid distortion under equipment. Wet, unstable areas must be dried out or replaced before starting placement of asphalt to avoid unanticipated and costly work shutdowns.
 - b. Locating wet or soft areas in advance can be accomplished by testing finished subgrade or subbase with a loaded truck. When the proof truck causes subgrade distortions, the subbase and subgrade must be dried out and reworked.
 - c. Construction of asphalt pavement should not proceed unless testing gives a reasonable indication that distortions will not occur during construction of overlying pavement.
3. Determining Cause
 - a. During spring and early summer, unstable subgrades caused by high moisture contents are encountered statewide. This condition is usually seasonal and tends to improve as warmer, dryer summer weather stabilizes subgrade. Additional pavement thickness is not justified to bridge over these particular soft subgrades because of their seasonal nature.
 - b. When evaluating individual cases of instability, experienced judgment is advisable because of the similarity in outward appearances between moisture in subgrade due to seasonal conditions and more serious causes such as frost boil, unsuitable material, etc.
 - c. If excess moisture is encountered, dry subgrade and re-compact.
4. Drying and Re-compaction
 - a. This treatment may be paid for as extra work provided the Project Manager authorizes it, and the work is closely monitored by the inspector and the Contractor did not cause the wet condition.
 - b. *SSHC Subsection 205.03* or special provisions require the Contractor to disc or take other action to remove moisture and then re-compact the soil at their expense. For a natural subgrade, Contractors are required, if necessary, to repair distorted areas by scarifying to a depth up to 150 mm (6 inches), aerating, and re-compacting at their expense. Over depth aeration and re-compaction below the top 6 inches (150 mm) shall be paid for as extra work (*SSHC Subsections 302.05, and 303.03*).
 - c. When repair, drying, and re-compaction are required to correct damage from Contractor's operation, all necessary repair will normally be done at the Contractor's expense. However, if the Project Manager determines that additional depth of aeration and re-compaction are needed, that should be paid as extra work (*SSHC Subsection 302.05*).

5. Special Treatments
 - a. When unusual problems are encountered with unstable subgrades or subbases, the District Construction Engineer should contact Materials & Research for assistance.
6. GRADELINE STRINGS AND EDGE ALIGNMENT
 - a. The inspector should make frequent measurements to ensure the guideline string has been correctly set and maintained. Support arms used to secure the guideline string shall be at intervals close enough to minimize chords on curves and other irregularities. Make the curve look like a curve.
 - b. Guideline strings placed on two-lane asphalt pavement should be located by measuring from redhead nails placed on centerline. Placement of a lower asphalt layer will cover redheads. For succeeding lifts, guideline string should be located by measuring from exposed nails used to hold string for each previous lift.
7. Procedures for Construction of Test Strips (*SSHC Subsection 503.04*)
 - a. *SSHC Subsection 503.04* requires the Contractor to construct a control (test) strip for all mixture types except SPS. Test strips are used to evaluate properties of asphalt mixture and identify an effective roller pattern.
 - b. The Contractor is responsible for properly constructing the test strip and providing related documentation to the NDOT inspector.
 - c. The NDOT inspector should document the procedure followed in constructing the test strip.
8. COLD WEATHER ASPHALT CONSTRUCTION
 - a. *SSHC Subsection 503.04* contains limitations for placement of asphalt and liquid bitumen under cold weather conditions. These restrictions apply to pavement surface temperature and time of year, and vary according to whether layer is surface course, lower binder, or base course, and nominal lift thickness. (*SSHC Table 503.03*)
 - b. Cold weather construction problems may show up in the form of increased roughness on profilograph, mat raveling, low density, high voids, segregation, slippage, or failure of tack coat to break. The Project Manager and inspector should be aware of other weather related conditions which may further limit placement.
 - c. After September 15, it is appropriate to require tarping and insulation of truck bodies, especially if hauls exceed 3 miles (5 km) (*SSHC Subsection 503.04*). However, if the Contractor can demonstrate that the asphalt temperature is not adversely affected by hauling, the tarp and insulation requirements should be waived.
 - d. No asphaltic concrete mixture shall be placed after October 31, unless the Contractor makes written request and the Engineer gives 'conditional' approval.

- e. Base temperature is the single greatest factor in the rate of cool down for freshly placed asphalt mat. Consequently, base temperature has direct effect on recommended minimum laydown temperature and rolling time available to obtain specified density.
 - f. Wind velocity, air temperature, and cloud cover are additional factors that affect the cooling rate of hot mix asphalt.
 - g. Cold surface temperatures cause emulsions to lose tackiness and increase breakage time resulting in higher risk of mat slippage.
 - h. For cool temperature work, the Contractor is allowed to lightly broom the unbroken' tack coat to eliminate puddling and facilitate the tack 'breaking'; also, adjusting dilution ratio and/or utilizing fast setting tack may be options to consider.
9. Use of Straightedge
- a. Pavement smoothness specification does not relieve the Contractor of responsibility for proper rolling and workmanship. Each pavement layer is to be inspected visually to ensure that surface is free of roller marks and distortion. Transverse joints are to be checked with a 10 foot (3 m) straightedge. The tolerance is 1/8 inch (3 mm).
 - b. Contractor should be encouraged to test directly behind the finish roller to allow correction of an identified 3/8 inch (10 mm) bump by re-rolling while the mixture is still hot enough to be affected.
 - c. Corrections for surface irregularities shall be made, if possible, before mixture has cooled to 150°F (65.6°C). A large percentage of irregularities can be corrected by finish rollers above this temperature.
 - d. The Contractor is not permitted to tight-blade the surface with a grader blade in hopes of minimizing any bumps, and no bonus will be allowed for any section regardless of the trace obtained if there is any evidence of such scrape marks in that section.
 - e. The inspector operating the surface checking straightedge should also observe the surface to ensure that all roller marks or roller wheel depressions are smoothed out during the finish rolling. The inspector should observe the longitudinal joints carefully to ensure that they have been smoothly rolled as the Specifications require. If surface is not being finished as Specifications require, the inspector shall stop construction until Contractor takes corrective action.
10. Checking Transverse Joints For Smoothness
- a. *SSHC Subsection 502.04* requires the use of a 10 foot (3 m) straightedge for checking transverse joints for smoothness. The Contractor should use a straightedge according to the following procedure:
 - (i) The first check with the straightedge shall be made before any saw cuts. The straightedge is used to determine where full thickness of each layer ends and tapered portion begins. The inspector shall require that saw cut be located in full thickness of layer. All of the layer extending beyond the saw cut, including tapered portion, is then removed.

While the joint is being constructed and checked, the Contractor should require the finishing machine to be stopped approximately 30 to 50 foot (10 to 15 m) from the joint. Construction shall not be permitted to continue until the checking has been completed. This permits repaving of the joint, with the finishing machine, if the straightedge indicates a poor riding surface was constructed.

- (ii) The second check with the straightedge is made after the finishing machine has constructed the new layer, but before rolling. The straightedge is used to locate irregularities in the newly constructed layer and any irregularities found that must be corrected by hand tools. When the straightedge indicates no high or low spots, compaction should be permitted with the initial roller.
- (iii) The third check with the straightedge is across the joint between cold pavement and hot mixture after compacted with initial roller. This third check indicates whether the correct amount of material has been placed. For instance, if freshly rolled layer is too high, it indicates too much material has been placed. If freshly rolled layer is too low, it indicates not enough hot mixture has been placed.

For that reason, high or low transverse joints are not usually corrected by additional rolling. Instead, corrections should be made by cutting or filling the rolled surface while the mixture is still warm and can be manipulated. If there are unusually high or low areas after rolling, paths must be shoveled through the pavement for finishing machine tracks. Finishing machine is then backed up to the joint and paving operation is started again.

- (iv) The above procedure shall be repeated as necessary until the straightedge indicates that a good riding joint has been constructed. If repeated repaving operations cause the mixture to cool to the extent that reuse becomes impractical, it should be removed and wasted.
- (v) The final procedure for insuring proper construction at transverse joints is checking for true edge alignment. Edge of the freshly rolled layer should be carefully trimmed by hand tools until it matches the alignment of adjoining cold pavement.

11. Longitudinal Joints

- a. To obtain adequate compaction at longitudinal joints, the Contractor shall place sufficient thickness of mix to compensate for 20 to 25 percent reduction in thickness that normally occurs from rolling. If thickness is insufficient prior to rolling, joint will usually be smooth in appearance but lack density because of inadequate compaction. Make sure density is checked along the joints.
- b. The vertical face of exposed, longitudinal joints must be tacked before the adjacent lane is placed. This treatment is very important to ensure a seal at the joint, general application with just the spray bar does not provide adequate coverage on the vertical edge, therefore, an additional application with the hand sprayer is necessary. Shields on distributor spray bar will help protect adjacent lanes (*SSHC Subsection 503.04*).

- c. If overlap is maintained at approximately 1 inch (25 mm) and thickness of joint is correct, brooming or raking may not be necessary to obtain a good joint. However, occasional corrections with hand tools may be necessary. When hand work is completed, excess material should be wasted as opposed to scattered on lane being constructed.
- d. True edge alignment controls the correct lap at each longitudinal joint. If insufficient lap, the joint will lack density resulting in raveling and joint deterioration. Excessive lap produces an objectionable wide scab of mixture on the surface next to the centerline joint, resulting in an unacceptable appearance.
- e. An intended lap of 1 inch (25 mm) with a variance of ½ inch (12.5 mm) will normally be the optimum overlap for longitudinal joint construction. To maintain these close variances, adjacent lane must be constructed with true edge alignment.
- f. The Contractor has the option of constructing a notched wedge joint between adjacent passes of asphaltic concrete lifts over 1 inch on pavement that will be open to traffic and contains uneven lanes.

12. Resurfacing

- a. When resurfacing two-lane PCC pavement, Contractors may locate guideline strings on shoulders along outer edges. To ensure that parallel alignment is used for an adjacent lane, the gradeline string for that lane shall be located by measuring across pavement from the first string.
- b. The finishing machine operator shall follow the guideline string exactly. If the machine goes off line for any reason, it shall be adjusted back onto the line immediately. It is incorrect to smooth out the edge alignment by coming back onto the line gradually. This results in long stretches where incorrect lap at longitudinal joint will occur. When batch trucks bump finishing machines off line on curves, movement is usually down the slope of the curve. If the machine is brought back on line gradually, an objectionable, long, straight chord will result in what is supposed to be curved edge alignment.
- c. Irregular edge alignment due to any cause, including adjustments of finishing machine, shall be corrected at once by hand tools. When corrections in edge alignment are unable to be made promptly after they occur, the inspector shall require the finishing machine to be stopped until workers catch up with making corrections.
- d. When constructing hand worked areas such as driveway returns and bridge approach tapers, edge alignment may become irregular during rolling because small, high, and low spots in hand worked surface tend to extend in width unevenly. Edge alignment of hand worked areas can be made true by first rolling the surface with a steel roller, then immediately trimming the edge with hand tools while the mixture is still hot and workable.

13. Laying Widths For Asphalt

- a. Plans for asphalt projects will show the overall dimensions of finished pavement.

- b. When spreading layers of asphalt 1 ½ inches to 2 inches (38 to 50 mm) in thickness, a typical 24-foot (7.2 m) pavement may broaden 2 to 4 inches (50 to 100 mm) in width during rolling. Therefore, laydown width before rolling might require) 3 inches (75 mm) less than final design width. An intended lap of 1 inch (25 mm) at the longitudinal joint is best for proper joint construction but seldom seen these days because the Contractor has to have someone “set up” the inch overlap. Use of a cutoff shoe when matching a longitudinal joint is not acceptable.
 - c. When using finishing machines that spread the pavement full width, the inspectors shall ensure that Contractors adjust the spreading width so the final dimensions conform to the dimensions specified in the project documents.
 - d. The finishing machine screed extensions are usually available in 6 inches (150 mm) increments. Where standard screed extensions are utilized to increase the paver width by more than 12 inches (300 mm), the paver auger must also be extended. Many new pavers are equipped with automatic screed extensions which can be adjusted to conform to the required width for most resurfacing situations. Some paver models have automatic auger extensions as well.
14. Policy for Placement of Template Correction on Overlay Projects
- a. When constructed under traffic maintained conditions and the design thickness is greater than 2 inches (50 mm) for the asphaltic concrete type and nominal aggregate size to be used on the surface layer, the asphaltic concrete shall be placed in more than one layer. The proposed compacted placement thickness of the top layer shall not exceed 2 inches (50 mm). Asphaltic concrete provided for template correction shall be placed with the lower layer or with the leveling course, if shown in the plans.
 - b. When constructed under traffic maintained conditions and the plans indicate that template correction is provided with a designed asphaltic concrete thickness if 2 inches (50 mm) or less, the total asphaltic concrete thickness, including template correction, shall be placed as a single layer.
15. Placement Rates for Hot Mix Asphalt Bases, Binder, and Surface Courses
- a. The inspector shall check contract quantities for accuracy.
 - b. In general, placement rates for hot mix asphalt shall be determined using the contract asphalt mass. (*Construction Manual 502.08*) The estimated unit mass from design standards used to calculate contract quantities will provide sufficient material for construction of design thickness for most mixtures used.
 - c. If the contract quantity is not sufficient to construct the required thickness, notify the Construction Division.
 - d. For lower layers on resurfacing projects, automatic controls should not be adjusted repeatedly based on tonnage yields taken at short intervals. Automatic controls should be allowed to correct for irregularities in underlying base without frequent adjustments. Accordingly, the placement

rate for individual truckloads will sometimes vary substantially from contract rate because of irregularities in old base. However, over longer distances, 1650 feet (500 m) or more, taking both sides of the pavement into account, inspectors should select a general spread rate that compares as closely as possible with contract quantities.

- e. For paved shoulders or other construction where dimensions are controlled by specified elevations, existing structures, or other unusual requirements, spread rates shall be adjusted as necessary.

16. Density Controls for Asphaltic Concrete Construction

- a. Specifications for asphaltic construction require each layer to be compacted to a density not less than a given percentage of the Rice voidless density.
- b. Density of pavement is determined from cores cut by the Contractor or by nuclear density gauges, normally on the working day following construction. The method of mix density determinations will be determined by the Contractor, and any disputes will be resolved with cores.
- c. One hot box sample per subplot [750 tons (680 Mg)] will be obtained from the roadway surface by the Contractor and transported to the field lab for testing. The lab will determine the voidless density. The location of the sample shall be a secret and it must be random.
- d. An average of the voidless densities for a day's production will be used to determine the degree of field density.
- e. Five samples shall be cut from each 3750 tons (3400 Mg) or use Nuclear Density Gauge to determine density.
- f. The 1,000-ton test strip (and smaller test strips in earlier contracts) is independent of the tonnage listed in the random sampling schedule provided to the PM. The random sampling schedule becomes active following the placement of the 1,000th ton of an approved test strip.
- g. The Specifications also describe a procedure for field density evaluation together with a schedule for payment adjustments when noncompliance occurs. Project inspection personnel shall observe the following:
 - The Contractor is required to take a prescribed number of samples at locations selected and marked out by the project inspector. The project inspector will witness the core sampling. A circle approximately 16 inches (400 mm) in diameter is adequate for identification of sampling location. The core should be taken from within the area identified. It is not appropriate for the Contractor to use a nuclear device to "hunt" for a particular spot to sample; coring locations are no longer random when a nuclear device is used in this fashion.
 - Sample locations are identified in the random sampling schedule which will be provided to the Project Manager by Materials & Research. Keep the location a secret. When the random location is noted as zero or the lane width (i.e., zero or 12 ft. on a 12 foot lane) the core shall be cut with the outer edge of the core barrel

no greater than 4 inches away (laterally) from the edge of the top of the mat for an unconfined edge or from the edge of the top of the hot mat (joint) for a confined edge. If using a nuclear gauge, the 4 inches would be measured to the edge of the gauge base. The percent density value at these edge of lane locations shall be adjusted upward by 2.5%, but to a value of no greater than 92.5%, and the resultant value used in determining the density pay factor." No initial value of 92.5 or greater shall be adjusted

- If the layer being sampled adheres to a lower layer, it may be necessary to sample through two or more layers or full depth. The Contractor will need to remove the extra depth by sawing the sample with a masonry saw. It may be necessary to cool the sample by refrigeration or ice to prevent damage during sawing. It is important that core drill bits be kept sharp.
- Each sample shall be inspected carefully by the Contractor and inspector prior to testing. Be sure each core sample is representative of the density of the mixture placed and not damaged. If damage is noticeable, discard without testing and take another to replace it.
- If tests indicate that density is less than the specified percentage, the sample shall be retested to ensure accuracy. The Contractor can request another random sample be taken. (See *SSHC Subsection 1028.03*)
- Tests on density samples give lower results if samples are damaged during handling. Contractors and project inspectors are advised to use extreme care when taking, transporting, and preparing cores for testing.
- Samples should be transported on hard flat surfaces to avoid loss of density by distortion. If necessary, samples should be stored in a cool place and on a hard flat surface.
- Specifications also require the Contractor to take density samples as promptly as practical. Samples should be taken no later than the working day following placement. If the Contractor is unable to comply with this timing, the project inspector shall stop construction until the Contractor is able to do so.
- NDOT personnel shall be responsible for performing density tests using the Contractor provided samples. Any failures should be reported to the Project Manager and to the Contractor on the day tests are performed.
- When rerolling is performed, ensure the area that is rerolled is the complete area of low density, not just the area of the sample.

17. Asphalt Compaction

- a. Many Superpave mixes exhibit what is called a "Tender Zone" during compaction. You will have to confirm the Contractor has determined the "Tender Zone" for the mix. Normally the "Tender Zone" is between 230° and 160°F. When the asphalt is between 230° and 160°F, stop

compaction rolling. Do the finish rolling below 160°F and make sure heavy and intense compaction rolling is done above 230°F.

18. Resolving Density - Void Conflicts
 - a. The project inspector should be aware that the field laboratory and compacted voids are to be tightly controlled. This may require more compaction effort for compliance. Become familiar with other controls by reading the [Materials Sampling Guide](#) and asking questions of Materials & Research personnel.
 - b. For the case where specified density is met, but field laboratory voids are outside designated limits for two moving average points, the production will cease. The Project Manager may allow production to start following agreement on corrective action to be taken. The Contractor will select the combination of rollers to be used and preliminary rolling pattern. Nuclear gauge readings would normally be taken after each pass or series of passes.
 - c. The inspector shall only observe and document this process. Documentation of type and amount of compaction effort shall be recorded. Inspector will then select and mark out five random core sites within the test site. Density cores taken by Contractor will be tested and results reported as soon as possible.
 - d. Cooperation between the project inspector, Materials & Research, and the Contractor is essential to reach a timely solution. If all anticipated results are not met, further experimenting with a different combination of rollers and operation should be performed. Changes in gradation may be one of the first items looked at by Materials & Research. Changes in performance graded binder content would be one of the last items. Relief from minimum laboratory voids specified may only be approved by Materials & Research.
19. Rumble Strips In Asphalt Shoulders
 - a. Rumble strips will be milled into shoulder on designated projects. Department will no longer accept rolled-in rumble strips.

20. QUALITY CONTROL MONITORING

- a. Requirements for monitoring a Contractor's quality controlled plant operation are shown below.

NDOT Monitoring Program for Asphalt Paving Plants	Quality Control Methods
<p>Before production begins, the Contractor's plant inspector and the NDOT plant monitor should discuss these duties, documentation, sampling and testing plans to ensure compliance with the contract. Any noncompliance or work quality deficiency shall be immediately reported to the Contractor's superintendent and the Project Manager. The Contractor shall be required to take corrective action. The monitoring requirements are minimum and should be increased if deficiencies occur until the problems are resolved.</p>	
Contractor's Plant Inspection/QC	NDOT Minimum Monitoring Requirement
<p>Stockpiles Observe construction of stockpiles to prevent segregation, contamination, and intermingling.</p>	<p>Inspect before construction begins and once a week thereafter.</p>
Plant Erection	
<p>Inspect material bin foundations. Assure sampling locations are safe and convenient.</p>	<p>Inspect for evidence of settlement. Inspect prior to calibration and after heavy rain.</p>
Plant Equipment	
<p>Check interlocks on aggregate feeders and performance graded binder delivery systems, screens for removal of oversize material, performance graded binder storage tank, tank stick, and general condition of all plant equipment.</p>	<p>Inspect all plant and testing equipment prior to calibration (including lab trailer).</p>
<p>Check scales for sensitivity and accuracy daily.</p>	<p>Check first day and once a week thereafter.</p>
Plant Sampling & Testing	
<p>The contract allows the contractor to test for gradations by either "cold feed" or "ignition burn-off of field sample". Determine moisture content of all aggregates including RAP. (When daily plant output is less than 750 tons); only one sample is required for every 750 tons of asphalt produced.)</p>	<p>Witness at least 1 of 4 process samples of each mix type.</p>
<p>Observe performance graded binder sampling.</p>	<p>Using proper sampling techniques, obtain 1 sample per 7500 tons for Level 1 suppliers and per 3750 tons for Level 2 suppliers and submit sample to Materials and Research Lab.</p>
<p>Obtain density cores and core thickness.</p>	<p>Identify random core locations, observe core cutting, transport to field lab, determine and record core densities, and core thickness.</p>
<p>1 of 4</p>	

NDOT Monitoring Program for Asphalt Paving Plants		Quality Control Methods
Contractor's Plant Inspection/QC	NDOT Minimum Monitoring Requirement	
<p>Documentation Prepare daily plant report.</p> <p>Document all checks, tests, and quantities in field books.</p> <p>Complete tank stick sheet.</p> <p>Check for approved sources and certifications for all materials (including material transferred from other projects) and document deliveries.</p> <p>Assure total certified quantities are sufficient for tons produced.</p> <p>Maintain file of all certified material tickets, worksheets, and forms submitted.</p>	<p>Audit entries daily.</p> <p>Audit entries daily.</p> <p>Audit daily.</p> <p>Audit once per week.</p> <p>Audit once per week.</p> <p>Obtain file at end of project.</p>	
<p>QC Maintain control charts and data sheets. Document all mix control changes. Document correlation results.</p>	<p>Monitor daily.</p>	
		2 of 4

NDOT Monitoring Program for Asphalt Paving Plants		Quality Control Methods
Contractor's Plant Inspection/QC	NDOT Minimum Monitoring Requirement	
<p>Plant Calibration Observe calibration and obtain copy of all calibration data.</p> <p>Obtain copy of job mix formula.</p> <p>Check cold feed bins for method of adjustment.</p> <p>Discuss mix designs and plant controls with Project Manager.</p>	<p>Observe calibration and review calibration data.</p> <p>Participate in check.</p> <p>Participate in discussion.</p>	
<p>Mix Control Monitor coating of aggregates and mixing time.</p> <p>Monitor and record air, performance graded binder, and mix temperatures on 2-hour intervals.</p> <p>Monitor truck loading procedures, amount of mix maintained in silo, and operation of hopper/silo gates to avoid segregation.</p> <p>Check aggregate proportions, interlocks, and cold feed bin gate settings daily.</p> <p>Inspect trucks for proper/improper use of cleaning fluids.</p> <p>Prepare containers and send to road for hot samples.</p>	<p>Observe each day of production.</p> <p>Check once each day of production.</p> <p>Observe each day.</p> <p>Check first day and weekly thereafter.</p> <p>Monitor daily.</p>	
		3 of 4

NDOT Monitoring Program for Asphalt Paving Plants		Quality Control Methods
Contractor's Plant Inspection/QC	NDOT Minimum Monitoring Requirement	
<p>Asphalt Delivery Determine quantities on hand and calculate performance graded binder added by tank stick or weighing. Compare with brodie meter daily.</p> <p>Responsible for proper and random sampling of hot asphalt mixture behind paver. Sampling frequency is one sample for each subplot 680 Mg (750 tons) produced.</p>	<p>Monitor once per day.</p> <p>Monitor daily.</p>	
		4 of 4

503.05 METHOD OF MEASUREMENT

1. *SSHC Subsection 503.03* covers equipment and procedures for measuring the mass of the asphalt materials. When automatic or semi-automatic measurement is used, continuous and direct observation of the measuring process by a scale inspector is not required. For manual measuring of loaded trucks, Project Manager may assign a scale inspector. This normally occurs only when accuracy in the measuring procedures is in question.
2. When witnessing is required, scale inspector should be positioned near Contractor's scale operator so measuring can be closely observed. Contractor's representative shall write the scale tickets and present them individually to scale inspectors for their signatures or initials before each truck leaves the plant.
3. PG Binder tank stabs must be taken daily prior to the start of production, before production of a different class of asphaltic concrete and upon completion of asphaltic concrete production for the plant and provided to the plant inspector. Any partial tanker loads of PG Binder must be weighed by the Contractor and a scale ticket and refinery information provided the plant inspector so that a 'Transfer of Asphaltic Materials' form can be completed and forwarded to the Project Manager of the subsequent project for the plant.

503.06 BASIS OF PAYMENT

1. When payment for an asphaltic concrete mixture is based on tons (megagrams), payment will also be made for performance graded binder as a separate item. Compensation will be made for all tons (megagrams) of asphalt binder incorporated into the construction within Specification tolerances. (*SSHC Subsection 503.05*)
2. Tons (megagrams) of performance graded binder paid is not deducted from tons (megagrams) of asphaltic concrete mixture measured for payment.
3. When small quantities of asphalt binder are involved, the design plan may state that performance graded binder is considered subsidiary to asphaltic concrete. Check the special provisions for this reference.
4. For specific mixes used as patching materials, or in an alternate bid situation, payment may not be made for performance graded binder.

5. Tank Measurement and Performance Graded Binder Content Determination
 - a. At batch plants, automatic or semi-automatic printouts record the actual mass of performance graded binder in each separate batch. This quantity may be used for payment.
 - b. Volume measurements will be converted to mass by computation. The amount in storage at beginning of project will be measured or estimated by the inspector and added to amount measured for payment. Asphalt binder remaining in storage at end of project and amount otherwise not used in the work will be measured or estimated by the inspector and deducted from amount measured for payment.
6. Measuring Asphalt Binder for Small Quantities
 - a. *SSHC Section 109* provides that by mutual agreement, the method of measuring asphalt binder for payment may be modified when small quantities or intermittent operations are involved.
 - b. If a recorded mass is not available, quantity may be calculated from intended asphalt binder percent with asphalt plant meter results providing further verification. For small quantities on a given day, the previous day's tank stick may be used as a check.
 - c. The project inspector should document procedure selected and reasons for doing so.
7. Asphalt Binder Quantities and Pay Adjustments
 - a. Asphalt binder contract quantities for a project are estimated based on a basic asphalt binder content identified in the Contractor's mix design.
 - b. When noncomplying viscosity or penetration tests occur, payment for asphalt binder incorporated into affected asphalt mixture is subject to price adjustment as prescribed in the *SSHC Subsection 503.06*.
8. PG Binder/RAP – Pay Adjustments
 - a. The Contractor's initiative to substitute RAP and correspondingly reduce the amount of performance graded binder should not be reason to negotiate a higher price for the binder because it is a major item of work. The Specifications will be modified to add this safeguard.
 - b. Binders from different suppliers should not be mixed.

504.00 TACK COAT

504.01 DESCRIPTION

1. Tack coat is a sprayed application of diluted emulsified asphalt to the existing surface, or a previously placed asphaltic concrete layer, which, once "broke", serves as an adhesive between that surfacing and a successive layer of surfacing.

504.02 MATERIAL REQUIREMENTS

1. SS-1, SS-1H, CSS-1, and CSS-1H grades are specified. Dilution of emulsion is required if non-uniform tack applications are experienced. Dilute at 1:1 ratio, i.e., 1-gallon (1 liter) emulsion to 1-gallon (1 liter) water.

2. Check the refinery analysis ticket that came with the shipment to determine whether the Emulsified asphalt has previously been diluted 50/50 or not.

504.03 CONSTRUCTION METHODS

1. Application Rate for Diluted Emulsion
 - a. Meet with the distributor operator prior to tack coat application to determine how the rate of application is controlled and to how the machine measures the gallons shot.
 - b. For diluted material, double the rates of undiluted material application. Example: 0.03 to 0.06 gal/yd² (0.14 to 0.28 L/m²) undiluted increased to 0.06 to 0.12 gal/yd² (.28 to .56 L/m²) dilute emulsion.
 - c. If unable to place asphaltic concrete within the same day of application, the Contractor is allowed to broom areas where traffic has tracked dirt onto the tacked surface and reapply tack coat at those locations. The project manager will decide whether or not to pay for this touch-up tack coat quantity; partially, dependent upon whether the delayed asphalt placement was beyond the contractors control or not.
2. Sample for Compliance
 - a. Sample emulsion at spray bar of distributor with bar valve in a circulating position, prior to dilution.
3. Settlement of Diluted Emulsions
 - a. Varying residue rates of diluted emulsion may be related to blending of original emulsion or settlement while in storage. To minimize this problem, the following steps are recommended:
 - Contractor emulsion delivered to storage should be gently circulated prior to pumping into distributor truck.
 - If Contractor obtains emulsion directly from terminal, the emulsion should be gently circulated prior to use each day.
 - b. Material in a storage tank can be circulated with a large diameter, slow turning propeller, or by pumping from top to bottom. Only a small amount of agitation is necessary. Forced air should not be used for agitation since it may cause the emulsion to break.

504.04 METHOD OF MEASUREMENT

1. Keep in mind, diluted emulsion as supplied normally contains 60% asphalt residue, therefore, a 1:1 field diluted emulsion will contain the minimum of 30% residue.
2. The quantity measured for payment is the net gallons (liters) of diluted emulsion applied to the surfacing from the distributor.
3. Ensure that the quantity applied meets the application rate requirement. (*SSHC Subsection 504.03*)

504.05 BASIS OF PAYMENT

1. Emulsified asphalt which falls outside the specified range (*SSHC Table 504.02*) will either be rejected or paid for at a reduced price.

505.00 ASPHALTIC CONCRETE CURB

505.01 DESCRIPTION

1. Asphalt concrete curb is curb built with the specified asphaltic concrete and to dimensions shown in the plans.

505.02 MATERIAL REQUIREMENTS

1. Asphaltic concrete used in construction of the curb will be the same type as the surface course or a commercially available asphaltic concrete approved by the Engineer.

505.03 CONSTRUCTION METHODS

1. Asphaltic concrete curb with a steeper than 45-degree face seemed to be a major consideration in a court's ruling. Since a 45-degree face is the design used on present plans, we should not be granting exceptions for any of our present or future contracts.
2. A number of Contractors have requested permission to construct asphaltic concrete curbs to a template and/or dimensions which did not conform to that shown in the plans. You do not have authority to grant such permission on projects.
3. The 'back of curb' must be staked to define where the start of the curb, the alignment and the end.
4. Tack coat will be applied to the surface where the curb is to be constructed. Heating of the surface may be required to achieve a bond with the new asphalt.
5. Care must be taken not to contaminate the asphalt with oil or gasoline leaks from the equipment or cleaning agents.
6. Once constructed, the curb and 2-foot gutter are to be sealed with tack coat.

505.04 METHOD OF MEASUREMENT

1. The curb length will be field measured for payment by the linear foot (meter).

505.05 BASIS OF PAYMENT

1. The work of constructing the curb is paid by the linear foot (meter); materials used are paid under other contract pay items.

506.00 ASPHALTIC CONCRETE ISLAND NOSES AND MEDIANS

506.01 DESCRIPTION

1. Asphaltic concrete island noses and medians are built with the specified asphaltic concrete and to dimensions shown in the plans.

506.02 MATERIAL REQUIREMENTS

1. Asphaltic concrete used in construction of the median and island nose will be the same type as the surface course or a commercially available asphaltic concrete approved by the Engineer.

506.03 CONSTRUCTION METHODS

1. Radius points defining the 'back of curb' of the median must be staked for the Contractor.

2. Tack coat will be applied to the surface where the median and island nose are to be constructed. Heating of the surface may be required to achieve a bond with the new asphalt.
3. Care must be taken not to contaminate the asphalt with oil or gasoline leaks from the equipment or cleaning agents.
4. Once the constructed, the median and island nose are to be sealed with tack coat.

506.04 METHOD OF MEASUREMENT

1. Only the work for constructing the 'island nose' is measured for payment; all work associated with the construction of the median is subsidiary to materials' contract pay items.

506.05 BASIS OF PAYMENT

1. The work of constructing the island nose is paid by the 'each'; materials used for the nose and median are paid under other contract pay items.

507.00 ASPHALTIC CONCRETE FOR STATE MAINTENANCE PATCHING

507.01 DESCRIPTION

1. The Construction Division, Final Reviewers Office, has seen estimates that were incorrectly prepared. The estimates do not split these items out from the participating items. Thus, they are not split out on the progress estimates, either.
2. Please check your projects to assure that these items are in a "State Funds Only" Section. If they are not, create a new section in SiteManager.
3. Contact Highway Coordinator Finals Supervisor if you have any questions.

507.02 METHOD OF MEASUREMENT

1. Asphaltic concrete shall be measured on certified scales and a ticket with tare weight (tons) and type of asphaltic concrete must accompany the load delivered to the State maintenance work site.

507.03 BASIS OF PAYMENT

1. Asphaltic Concrete for State Maintenance Patching and Performance Graded Binder for State Maintenance Patching are always nonparticipating items and should be paid for with State funds only.

508.00 JOINT SEALING – ASPHALTIC TO CONCRETE

508.01 DESCRIPTION

1. This work consists of sealing joints where asphaltic concrete abuts Portland cement concrete.

508.02 MATERIAL REQUIREMENTS

1. Reference the [Materials Sampling Guide](#) for material acceptance and any sampling requirements.

508.03 CONSTRUCTION METHODS

1. Clean joint and dry. Nothing above joints. Nice even flow, no bubbles.

508.04 METHOD OF MEASUREMENT

1. Longitudinal joints are field measured by the station.
2. Transverse joints are measure by the linear foot (meter).

508.05 BASIS OF PAYMENT

1. After receiving the material's test results and a deviation percentage has been calculated, the joint sealing shall be paid for at the contract unit price multiplied by the Pay Factors in *SSHC Table 508.02*.

509.00 BITUMINOUS SAND BASE COURSE

509.01 DESCRIPTION

1. This work consists of providing and incorporating aggregates, mineral filler and cut-back or emulsified asphalt into the sand roadbed and compacting this mixture to provide a stable foundation course.

509.02 MATERIAL REQUIREMENTS

1. Material shall meet the requirements of SSHC Subsection 509.02.

509.03 EQUIPMENT

1. Blade machines or traveling mixing plants are equipment suitable for mixing the materials. This equipment, as well as compaction equipment, are specified in *SSHC Subsection 509.03*.

509.04 CONSTRUCTION METHODS

1. Construction specifications and procedures are provided in *SSHC Subsection 509.04*.

509.05 METHOD OF MEASUREMENT

1. Truck boxes need to be measured to determine the volume, in cubic yards per load, of mineral aggregates and mineral filler hauled to the delivery point. The Contractor is required to strike off the material to uniform heights for accurate volume.
2. Asphaltic oil and emulsified asphaltic materials are measured for payment in gallons.
3. "Bituminous Sand Base Course" is paid by the 100-foot station and irregular areas measured in equivalent 100-foot stations.

509.06 BASIS OF PAYMENT

1. Water used during mixing operations and 'fog seal' are paid for as separate pay items.
2. When materials do not meet contract requirements, deductions will be made according to *SSHC Tables 503.01A and B*.

510.00 COLD MILLING

510.01 DESCRIPTION

1. Cold milling is the removal of a predetermined maximum depth of existing surfacing to correct elevations, slopes and surface irregularities. The different types of milling are defined in *SSHC Subsection 510.01*.

510.02 MATERIAL REQUIREMENTS

1. The millings are to pass the 2-inch (50 mm) sieve shall not be contaminated with underlying material.

510.03 EQUIPMENT

1. The milling machine shall be self-propelled with automatic controls, able to perform the work to the Engineer's satisfaction.

510.04 CONSTRUCTION METHODS

1. Before starting the cold milling operation, inspect the existing surfacing for slope. Does the slope of the roadway reflect the slope shown on the plans? If not, the cold milling operation can help to correct these slopes.
2. Keep in mind that the milling machine should never mill a greater depth than that shown on the plans.
3. In checking slopes, pay particular attention to curve superelevations and transitions. Most often, the existing curve transitions will not align with the transitions defined by the construction plans, therefore, it is advisable to follow the existing transition, for the most part, gradually making the necessary adjustments within the transitioning to the plan superelevation. (Note: If the existing curve superelevation is shallow, milling on the high side of the curve might be eliminated altogether. If the existing superelevation is steeper than plan, the low side might not require milling.) The transition inflection points need to be staked and the procedure discussed ahead of time with the milling foreman.
4. The milling machine operator will require stakes along the shoulder of the roadway and/or painted on the existing surfacing to indicate where the transition begins, transition inflections and where the transition achieves full superelevation.
5. The mill head is often wider than the lane so, in addition to depth, ensure the milling machine is not milling a greater lane width than that shown on the plans. Also make sure the Contractor is precisely following and preserving the staked centerline (CL).
6. As the cold milling operation ensues, constantly monitor the milled depth at centerline (CL), depth at the outer edge of the lane, the cross-sectional slope and the width. Any corrections made at this point will be beneficial to future overlay processes.
7. Also, inspect the milled surface directly behind the milling operation. Check the milled surface pattern for indication of missing teeth or an unusually coarse surface. If the milled surfacing is coarse, it is usually an indication that the milling operation is moving too fast; check the millings for larger chunks of asphalt unusable for RAP in asphaltic concrete. The Contractor should be advised to slow the cold milling operation if either or both of these are observed.

8. Ensure that milled material is not falling onto the surfacing ahead of the milling machine which could cause the machine to rise up on piles of millings resulting in 'bumps'.
9. When they come back to match lanes make sure there's no elevation difference at CL.
10. Once the milling operation is completed, the milled surface needs to be broomed and any milling piles removed.

510.05 METHOD OF MEASUREMENT

1. Methods of cold milling measurements are defined in *SSHC Subsection 510.05*.

510.06 BASIS OF PAYMENT

1. Basis of Payment for the cold milling types are defined in *SSHC Subsection 510.06*.

511.00 SALVAGING AND STOCKPILING BITUMINOUS MATERIAL

511.01 DESCRIPTION

1. This work consists of salvaging, by cold milling, the existing bituminous surfacing and hauling, and stockpiling the material to specified locations for the Department.

511.02 MATERIAL REQUIREMENTS

1. The material shall be pulverized until it passes the 2 inch (50 mm) sieve and be free of underlying material.

511.03 EQUIPMENT

1. Cold milling equipment is described in *SSHC 510.03 & Construction Manual 510.03*.

511.04 CONSTRUCTION METHODS

1. Each District remains responsible for specifying the disposition of millings.
2. Specifications and special provisions need to specify which millings are available and at what cost.
3. Pre-letting information should only be released through the Final Plans Coordinator so that no relevant bidding information is withheld from any possible bidder.

511.05 METHOD OF MEASUREMENT 1. Salvaging and stockpiling of bituminous material is field measured by ton (Megagram) of material placed in stockpile.

511.06 BASIS OF PAYMENT

1. Basis of payment is defined in *SSHC Subsection 511.06*.

512.00 BITUMINOUS SURFACE COURSE

512.01 DESCRIPTION

1. This work consists of constructing a surface course composed of milled or pulverized bituminous material, as per contract.

512.02 MATERIAL REQUIREMENTS

1. The bituminous material is to be pulverized until it will pass the 2-inch sieve.

512.03 CONSTRUCTION METHODS

1. Ensure that the Contractor has removed all vegetation and has graded the area properly on which the material is to be placed.
2. The Contractor will, then, place and compact the bituminous material as shown in the contract.

512.04 METHOD OF MEASUREMENT

1. The bituminous surface course is measured for payment by the square yard (square meter).

512.05 BASIS OF PAYMENT

1. The payment for item, 'Bituminous Surface Course' is full compensation for all work described in this section.

513.00 FOG SEAL

513.01 DESCRIPTION

1. A fog coat or fog seal is a single shot of asphalt material in a very light application, generally 0.10 gal./yd. 2 (0.45 L/m²) or less without a sand cover. This seal is used in the preparation for heavier applications of asphalt and cover material where the pavement surface has deteriorated to the extent that too much asphalt would be absorbed by the dry pavement and cause failure of the final seal coat. It is also used to provide a seal on a permeable pavement where a regular seal coat is not always desirable. It has been used to seal the surface of plant mix pavements constructed late in the fall where inadequate compaction is sometimes responsible for a slight raveling during the following winter.
2. Fog seals must be used with discretion and caution. They are used only to correct defects in existing pavements. Application of fog seals consists mainly of careful control of the distributor. Verify that the distributor does not exceed 35 mph (50 km/hr). Application rate should be based on the amount of asphalt that will readily penetrate the mat without leaving an excess on the surface. Surface voids should be sealed but not filled, since this would cause slick or fat spots. Generally, the surface texture of the mat should show little change after application. The initial visual effect should be that of a light paint job. The rate of application should be determined by short test sections. More asphalt may be required for open textured or dry old pavements. Diluted emulsion resin runs about 0.10 to 0.12 gal./yd 2 (0.45 to 0.54 L/m²).

513.02 MATERIAL REQUIREMENTS

1. Materials specifications and dilution instructions are found in *SSHC Subsection 513.02*.

513.03 CONSTRUCTION METHODS

1. Construction methods are found in *SSHC Subsection 513.03*.

513.04 METHOD OF MEASUREMENT

1. Fog seal is measured in diluted gallons (kiloliter). Sand is not measured for payment.

513.05 BASIS OF PAYMENT

1. Emulsified asphalt which falls outside the specified range (*SSHC Table 513.01*) will either be rejected or paid for at a reduced price.

514.00 MICROSURFACING

514.01 DESCRIPTION

1. Microsurfacing is a slurry seal consisting of a mixture of a polymer modified emulsion, fine graded blend of crushed aggregate and filler, additives and water.
2. Rut boxes are used to fill deep ruts and scratch course for minimal rutting, then final lift full width.
3. It is a hard wearing surfacing seal which extends the life of the pavement by filling ruts and restoring surface profile, additionally, waterproofing and providing a skid resistant surface.

514.02 MATERIAL REQUIREMENTS

1. It is very important to get aggregate and chat samples and run gradation tests prior to production.
2. The Contractor will submit a mix design using the FCAC "MICROSURFACING – Job Mix Design" MS Excel Workbook.

514.03 EQUIPMENT

1. Equipment requirements are found in *SSHC Subsection 514.03*.

514.04 CALIBRATION METHODS

1. The laydown machine/mixing unit must be calibrated and note initial readings prior to production. (FCAC "Microsurfacing" or "Microsurfacing with automated system" MS Excel Workbooks)

514.05 CONSTRUCTION METHODS

1. Take readings for pay items from machine at the beginning and end of the production day.
2. Count bags of cement used at the end of the day. Some machines keep track.
3. Make sure surfacing is clean. Sweep.
4. Watch that there are no overlaps.
5. Keep traffic off fresh mat.

514.06 METHOD OF MEASUREMENT

1. The inspector will document field records in the FCAC "Microsurfacing" or "Microsurfacing with automated system" MS Excel Workbooks and SiteManager.

514.07 BASIS OF PAYMENT

1. Water used for prewetting the roadway surface and microsurfacing additives are not measured for payment but are considered subsidiary to other pay items.
2. Emulsified asphalt which is outside the specified range (*SSHC Table 514.03*) will either be rejected or paid for at a reduced price.

515.00 ARMOR COAT OR CHIP SEAL

515.01 DESCRIPTION

1. Armor Coat and Chip Seal are pavement surface treatments where the existing surfacing is sprayed with emulsified asphalt and, subsequently, a layer of fine aggregate is spread evenly over it.
2. The asphalt serves to adhere the aggregate to the existing surface thus resulting in a hard wearing surfacing seal which extends the life of the pavement by waterproofing and providing a skid resistant surface.

515.02 MATERIAL REQUIREMENTS

1. The aggregate must meet the gradation requirements of *SSHC Table 515.01, 515.02 or 515.03*, depending upon the chip seal or armor coat specified.

515.03 CONSTRUCTION METHODS

1. It is important to be alert to ambient air temperatures dropping below 60°F (16°C) and any precipitation in the weather forecast. The existing surface must be free of any standing water.
2. Emulsified asphaltic material application rates are specified in *SSHC Subsection 515.03*.
3. Before beginning work, the Contractor must demonstrate the ability to distribute a uniform coat of emulsified asphalt and aggregate by providing a 10-foot test strip on tar paper or other suitable material.
4. The emulsified asphalt application shall commence with a running start on a strip of tar paper and stop the run in the same way to ensure a straight, seamless, transverse construction joint.

The cover aggregate must be applied within 1 minute of the emulsified asphalt application and rolling within 15 minutes of the aggregate cover.

5. A minimum of 3 self-propelled, multiple-wheel, pneumatic-tired rollers must be used.
6. Sweeping must be conducted only during daylight hours. Care must be taken not to sweep aggregates toward nor cause conditions of poor visibility for vehicles traveling through the work zone.

515.04 METHOD OF MEASUREMENT

1. Emulsified asphalt is measured by gallons (liters) and aggregates by cubic yards (cubic meters).

515.05 BASIS OF PAYMENT

1. Aggregates not meeting the gradation requirements of *SSHC Table 515.01, 515.02 or 515.03* will not be accepted for payment.

2. Emulsified asphalt which falls outside the specified range (*SSHC Table 515.04*) will either be rejected or paid for at a reduced price. Emulsified asphalt used in the test strip are subject to these same payment adjustments.

516.00 BITUMINOUS PAVEMENT PATCHING

516.01 DESCRIPTION

1. Bituminous pavement patching includes removing and disposing of surfacing, correcting faulty subgrade and compacting of asphaltic concrete patching material.

516.02 MATERIAL REQUIREMENTS

1. Guidance for material requirements is provided in *SSHC Table 516.01*.

516.03 EQUIPMENT

1. In the past, a backhoe has been used but a skidsteer with a milling head attachment has proven to be more effective for removing the existing bituminous surfacing for patching.

516.04 CONSTRUCTION METHODS

1. Once the bituminous material has been removed and the underlying material stable and uniformly compacted, apply tack coat as directed in *SSHC Subsection 516.04*.

516.05 METHOD OF MEASUREMENT

1. Methods of measurement for payment are specified in *SSHC Subsection 516.05* and/or special provisions.

516.06 BASIS OF PAYMENT

1. Specifications for basis of payment are found in *SSHC Subsection 516.06* and/or special provisions.

517.00 PRIME COAT

517.01 DESCRIPTION

517.02 MATERIAL REQUIREMENTS

517.03 CONSTRUCTION METHODS

517.04 METHOD OF MEASUREMENT

517.05 BASIS OF PAYMENT

518.00 FABRIC REINFORCEMENT

518.01 DESCRIPTION

518.02 MATERIAL REQUIREMENTS

518.03 CONSTRUCTION METHODS

518.04 METHOD OF MEASUREMENT

518.05 BASIS OF PAYMENT

519.00 CRACK SEALING BITUMINOUS SURFACING

519.01 DESCRIPTION

1. This work consists of preparing and sealing cracks in bituminous surfacing.

519.02 MATERIAL REQUIREMENTS

1. Reference the [Materials Sampling Guide](#) for material acceptance and required samples.

519.03 CONSTRUCTION METHODS

1. It is imperative that cracks be clean and dry and that a hot lance be used to warm the sidewalls of the crack prior to applying sealant. If the crack is 3/8" or less, the crack must be widened, as per *SSHC Subsection 519.03 a*.
2. The crack is to be slightly overfilled from the bottom up and squeegeed to surface level leaving a 2 to 4-inch width sealant over the crack. Closely monitor sealant temperatures ensuring that they stay within specification limits.
3. As a safety reminder, be especially aware of your surroundings and traffic entering the work zone.

519.04 METHOD OF MEASUREMENT

1. The work of crack sealing bituminous surfacing is measured by the linear foot of cracks sealed.

519.05 BASIS OF PAYMENT

1. After receiving the material's test results and a deviation percentage has been calculated, the crack sealing shall be paid for at the contract unit price multiplied by the Pay Factors in *SSHC Table 519.03*.

520.00 BITUMINOUS PATCHING OF CONCRETE PAVEMENT

520.01 DESCRIPTION

520.02 MATERIAL REQUIREMENTS

520.03 CONSTRUCTION METHODS

520.04 METHOD OF MEASUREMENT

520.05 BASIS OF PAYMENT

520.06 TARGET VALUES FOR ASPHALTIC CONCRETE PRODUCED

1. The tolerances specified for asphaltic concrete are provided for reasonable variances only. Whenever regular and repeated variances from target values occur, the Project Manager shall insist on quick and corrective action by Contractor to secure target values, not simply within tolerance.
2. The above comments are addressed to asphalt binder content, aggregate tolerance and specifically to air voids and VMA values.

DIVISION 600

PORTLAND CEMENT CONCRETE PAVEMENT

**DIVISION 600
PORTLAND CEMENT CONCRETE PAVEMENT**

600.00 CONCRETE PAVEMENT CHECKLISTS

600.01 CHECKLISTS

SSHC References:

Section 600 Portland Cement Concrete Pavements

Section 603 Concrete Pavement

Section 1002 Portland Cement Concrete

Section 1010 White Opaque Polyethylene Film and White Burlap--Polyethylene Sheeting For Curing Concrete

Section 1011 Burlap For Curing Concrete

Section 1012 Liquid Membrane-Forming Compound For Curing Concrete

Section 1014 Joint Sealing Filler

Section 1015 Preformed Joint Filler

Section 1033 Aggregates

Inspection Crew:

Placement Inspector

Certified Plant Inspector173536850020

Inspection Equipment:

Slump Cone (recommended but not required)

Air Meter (pressure)

Thermometer

Cylinder Molds and Lids

Rod

Mallet

Strike Off Bar

Ruler

10 foot (3 m) straightedge

Subgrade Template

Placement Procedures:

1. Preplacement check of equipment. Verify vibratory, paver and all other equipment are operational.
2. Check subgrade. Use LWD to check stiffness.
3. Check base or foundation course. Use LWD to check stiffness.
4. Check placement of steel if present.

5. Check Form setting and alignment, if used.
6. Slab thickness and crown should be checked 3 times a day.
7. Have contractor wet grade before concrete placement.
8. Keep track of time from placement on grade to machine finishing.
9. Test concrete for air content and make cylinders when the consistency of the concrete appears different and as a minimum according to the Materials Sampling Guide.
10. Watch concrete placement for compliance with specifications.
11. Check machine installation of steel.
12. Should not use water as a finishing aid; may use an orchard sprayer gingerly or an approved chemical finishing aid/evaporation retardants are also authorized.
13. Check surface with straightedge. Remove depressions and irregularities.
14. Check tining for conformance to specification.
15. Stamp station numbers in the plastic concrete.
16. Check application of spray curing compound.
17. Inspect prepared joints prior to sealing.
18. Inspect sealed joints.
19. Observe contractor's performance of pavement smoothness testing.
20. Notify coring crew of placement.
21. Each day prepare NDOT Form 85, Pavement Laid Report.
22. Reset section corner markers.
23. Check tickets for volume and proportioning per Contractors mix design and specifications.
24. Keep tickets in project file. Generate Proportion report in SiteManager daily.

Construction Critical Area:

1. Maintain a uniform roll, of about 4 inches (100 mm), of concrete ahead of the front screed and a minimum of a 2 inches (50 mm) roll ahead of the rear screed.
2. Placement of tie bars and key ways.
3. Verify string line is tight and in correct position.
4. Verify layout will place longitudinal joints at correct locations. (Usually should coincide with lane lines.)
5. Verify Contractor uses a 10 foot (3 m) straightedge behind paver to check smoothness.
6. The time the concrete is in the truck and the time it sits on the grade should not exceed the specifications limits.
7. Trucks that segregate concrete or have cement balls must not be used.
8. The timing of cure application and even coverage.

9. Record the timing of joint sawing. This is the Contractor's responsibility to determining the schedule.

Safety Areas:

NDOT Tests:

1. ASTM C 31 Making and Curing concrete test specimens.
2. ASTM C 143/C 143M Slump of Portland Cement Concrete.
3. ASTM C 172 Sampling of Fresh Concrete.
4. ASTM C 231 Air Content of Freshly Mixed Concrete by the Pressure Method.

600.02 CONCRETE PLANT CHECKLIST

*SSHC References: Section 603 Concrete Pavement
Section 1002 Portland Cement Concrete
Section 1004 Portland Cement
Section 1005 Water for Concrete
Section 1006 Calcium Chloride
Section 1007 Concrete Admixtures
Section 1008 Fly Ash
Section 1009 Silica Fume
Section 1033 Aggregates*

Inspection Crew: Certified Plant Inspector. Verify Contractor's or Producer's personnel is Certified Plant Inspector. Batch weight equipment in list below to be utilized by contractor personnel

Inspection Equipment: Large balance or Dunagan buoyancy apparatus (5 kg)
Small balance (2 kg)
Set of gram weights, 2 kilogram weights
Set of coarse aggregate sieves and a set of fine aggregate sieves
Mechanical shaker
2 burner gas or electric stove
Sampling bags and containers
Security seals for aggregate samples
Slump Cone
Air Meter (pressure)
Cylinder Molds and Lids
Thermometers
Rod
Mallet
Strike Off Bar

Ruler

Water Bottle

Plant Procedures:

1. Check Plant Certification Checklist before production begins. This may be accompanied with a check of the equipment.
2. Check cement and admixtures in accordance with the APL and mix design before production begins and when new materials arrive.
3. Check aggregate piles for segregation and contamination. (SSHC Subsection 1033.03)
4. Obtain materials samples as required by the Contract.
5. Observe testing of materials as required by the Contract.
6. Each day check the batching operation as needed.
7. Collect Proportioning Reports daily.
8. Check truck ticket for correct volume as necessary.
9. Report Proportioning Reports in SiteManager daily. Keep truck tickets in project file.

Construction Critical Areas:

1. Cementitious material bins must be watertight and prevent contamination.
2. Coarse aggregate stockpiles must be watered.
3. Admixtures need to be protected from freezing.
4. Delivery trucks need to be checked for wash water before batching each load of concrete.

Safety Areas:

NDOT Tests:

1. ASTM C 31 Making and Curing concrete test specimens.
2. ASTM C 143/C 143M Slump of Portland Cement Concrete.
3. ASTM C 172 Sampling of Fresh Concrete.
4. ASTM C 23 Air Content of Freshly Mixed Concrete by the Pressure Method.
5. NDOT T 27 sieve Analysis of Fine and Coarse Aggregates
6. AASHTO T 248 Reducing Field Samples of Aggregate to Testing Size
7. NDOT T 506 Determination of the Free Moisture Content of Aggregates
8. NDOT T 504 Determination of Clay Lumps, Shale, and Soft Particles in Coarse Aggregate and of Clay Lumps in Fine Aggregate and Sand and Gravel Aggregates
9. AASHTO T 255 Total Moisture Content of Aggregates by Drying

600.03 CONCRETE PAVEMENT REPAIR CHECKLIST

*SSHHC References: Section 600 Portland Cement Concrete Pavements
Section 605 Concrete Pavement Repair
Section 1002 Portland Cement Concrete
Section 1012 Liquid Membrane-forming Compound For Curing Concrete
Section 1013 Bituminous Liquid Compound For Curing Concrete
Section 1014 Joint Sealing Filler*

Inspection Crew: Pavement inspector
Certified Plant Inspector

Inspection Equipment: Slump Cone
Air Meter (pressure)
Cylinder Molds and Lids
Rod
Mallet
Strike Off Bar
Ruler
10 foot (3 m) straightedge
Stringline (Subgrade Checking)
Water Bottle

Patching Procedures:

1. Mark areas of pavement removal.
2. Preplacement check of the equipment.
3. Check subgrade.
4. Check base or foundation course.
5. Check placement of steel.
6. Check Form setting and alignment, if used.
7. Have contractor wet grade before concrete placement.
8. Test concrete for air content and make cylinders when the consistency of the concrete appears different and as a minimum according to the Materials Sampling Guide.
9. Watch concrete placement for compliance with specifications.
10. Should not use water as a finishing aid; may use an orchard sprayer gingerly or an approved chemical finishing aid/evaporation retardants are also authorized.
11. Check tining for conformance to specification.
12. Watch curing operation for conformance to specifications.
13. Keep track of ambient temperature during curing period.

Construction Critical Area:

1. Specified mixing is required to insure uniform dispersion of admixtures.
2. Proper cure procedures are critical to insure the early strength is achieved.

Safety Areas:

NDOT Tests:

1. ASTM C 31 Making and Curing concrete test specimens.
2. ASTM C 143/C 143M Slump of Portland Cement Concrete.
3. ASTM C 172 Sampling of Fresh Concrete.
4. ASTM C 231 Air Content of Freshly Mixed Concrete by the Pressure Method.

601.00 GENERAL REQUIREMENTS

601.01 GENERAL

601.02 EQUIPMENT

1. General
 - a. All equipment to be used on the project should be thoroughly inspected and measuring equipment should be carefully calibrated before the start of production. All calibration data should be recorded by the Contractor and the report stored in OnBase®. These notes should include a description of each piece of equipment such as make, model number, etc.
 - b. Repeated breakdown of a piece of paving equipment is sufficient reason to suspend paving operations until the machine is repaired and brought into proper operating condition or replaced. (*SSHC Subsection 105.01*)
2. Batching Equipment
 - a. Batching equipment should be certified with the National Ready Mixed Concrete Association (NRMCA) Quality Control Manual - Section 3 - Plant Certification. (See *SSHC Subsection 1002.03*)
3. Cement Bulk Handling Equipment
 - a. The principal concern with regard to handling cement is moisture. Contact between cement and water prior to entering the mixer must be positively prevented.
4. Scales
 - a. Scales shall be in compliance with National Ready Mixed Concrete Association, Quality Control Manual, Section 3, Plant Certification.
5. Concrete Mixers
 - a. General - Equipment for handling and mixing concrete shall conform to the requirements of *SSHC Sections 601, 603, and 1002*.
 - b. The inspector should be familiar with the mixing drum, water meter, timing device, and Air Entraining Admixture (AEA) dispenser. Check the inside of the drums for worn pick-up or throw-over blades. The contractor is required to provide information making it possible to check the wear accurately. The blades should not be worn more than 10 percent of the

- original height. Check the capacity plate for size of batch and manufacturer's recommendation for speed of rotation of the mixing drum.
- c. The mixer must be equipped with a timing device which locks the discharge lever in the closed position until the end of the full mixing time. Set the timing device for the specified mixing time after all materials are in the drum. After paving operations begin, the mixing time should be checked with the mixer operating under load. The door of the timing box shall be kept closed and locked except during repair or adjustment.
 - d. Water Measuring Devices - The water tank should be inspected and the accuracy of the gauge checked. Using a 55 gallon drum and a platform scale furnished by the contractor, the tank should be calibrated for each gauge setting through the operating range. The measuring device shall have an accuracy of 1.0 percent of the metered volume.
 - e. Make at least two trials for each setting of the dial to insure consistency in the measuring device. Record the calibration in the inspector's notebook. Check the valves to see that no water dribbles into the mixer drum when the tank is shut off.
 - f. Admixture Dispensers - When an admixture is to be added to the mix it should be arranged to enter the drum with the mixing water. The volume graduations on the AEA dispenser should be checked by measuring the amount released at each setting and the results recorded. The amount dispensed should be accurate within 3 percent of the quantity specified for each batch.
 - g. Mixer Performance Tests - A decrease in mixing time can be made under certain conditions, including the use of interlocked automatic batching. The basis for permissible reduction of mixing time is the contractor's mixer performance test.
 - h. Specific sampling and testing procedures, equipment list and method of reporting are included under the Materials & Research [Materials Sampling Guide](#), [Standard Methods of Tests](#), and SiteManager.
6. Hauling Equipment (*SSHC Subsection 603.03*)
- a. May be one of two different types, depending on the setup at the plant:
 - (i) Trucks which have drums or containers (dump trucks) in which central mixed concrete is delivered to the project. (30 minute limit till discharged.)
 - (ii) Trucks which have a concrete mixer mounted on the truck bed to provide complete mixing of concrete ingredients after they have been batched or blended at the central mixing plant. (90-minute limit till discharged.)
 - b. Trucks and Mixers - Each vehicle shall have a metal plate attached and listing:
 - (i) Designed use.
 - (ii) Concrete capacity
 - (iii) Rotation (RPMs) of the mixing drum or blades.

- original height. Check the capacity plate for size of batch and manufacturer's recommendation for speed of rotation of the mixing drum.
- c. The mixer must be equipped with a timing device which locks the discharge lever in the closed position until the end of the full mixing time. Set the timing device for the specified mixing time after all materials are in the drum. After paving operations begin, the mixing time should be checked with the mixer operating under load. The door of the timing box shall be kept closed and locked except during repair or adjustment.
 - d. Water Measuring Devices - The water tank should be inspected and the accuracy of the gauge checked. Using a 55 gallon drum and a platform scale furnished by the contractor, the tank should be calibrated for each gauge setting through the operating range. The measuring device shall have an accuracy of 1.0 percent of the metered volume.
 - e. Make at least two trials for each setting of the dial to insure consistency in the measuring device. Record the calibration in the inspector's notebook. Check the valves to see that no water dribbles into the mixer drum when the tank is shut off.
 - f. Admixture Dispensers - When an admixture is to be added to the mix it should be arranged to enter the drum with the mixing water. The volume graduations on the AEA dispenser should be checked by measuring the amount released at each setting and the results recorded. The amount dispensed should be accurate within 3 percent of the quantity specified for each batch.
 - g. Mixer Performance Tests - A decrease in mixing time can be made under certain conditions, including the use of interlocked automatic batching. The basis for permissible reduction of mixing time is the contractor's mixer performance test.
 - h. Specific sampling and testing procedures, equipment list and method of reporting are included under the Materials & Research [Materials Sampling Guide](#), [Standard Methods of Tests](#), and SiteManager.
6. Hauling Equipment (*SSHC Subsection 603.03*)
- a. May be one of two different types, depending on the setup at the plant:
 - (i) Trucks which have drums or containers (dump trucks) in which central mixed concrete is delivered to the project. (30 minute limit till discharged.)
 - (ii) Trucks which have a concrete mixer mounted on the truck bed to provide complete mixing of concrete ingredients after they have been batched or blended at the central mixing plant. (90-minute limit till discharged.)
 - b. Trucks and Mixers - Each vehicle shall have a metal plate attached and listing:
 - (i) Designed use.
 - (ii) Concrete capacity
 - (iii) Rotation (RPMs) of the mixing drum or blades.

- c. Mixers and agitators shall be operated within the limits of capacity and speed of rotation designed by the manufacturer of the equipment. When used as a mixer, it is important for the inspector to make sure that the equipment is not loaded beyond its capacity. Blade wear should be checked against the manufacturer's design. Blade height should be at least 90 percent of original height. There should be no appreciable accumulation of hardened concrete. Control and measurement of water added should be clearly inspected. Revolution counters should be checked.
- 7. Subgrade Trimmer (*SSHC Subsection 302.03*)
 - a. Check the setting of the cutting blades to secure the exact subgrade crown and elevation. The subgrade trimmer, if used, should operate at least 300 to 500 feet (90 m to 150 m) ahead of the concrete placement operation. Usually, the segment that is to be paved will be trimmed at least one day prior to concrete being placed on the job.
- 8. Concrete Spreader (*SSHC Subsection 601.02*)
 - a. The spreader or mechanical strike-off must be self-propelled and equipped with:
 - (i) A power-driven spreading device.
 - (ii) An adjustable strike-off blade capable of striking off the concrete at any required elevation within the forms. This requirement anticipates the construction of reinforced concrete pavement in two courses. The strike-off should be adjusted so that some concrete will be carried in front of the blade.
 - (iii) Vibrators, either internal or surface type, capable of consolidating the pavement to its full width and depth. These should be checked for frequency of vibration with a contractor supplied tachometer.
- 9. Finishing Equipment
 - a. *SSHC Subsection 601.02* provides for use of various types of concrete pavement finishing machines. Mainline paving is intended to be placed with a finishing machine designed for concrete paving. Approval may be given for alternate types of finishing equipment based on satisfactory field performance. Should a new machine be brought on the job and contractor's staff are not experienced with its operation, a qualified manufacturer's representative should be present until equipment is in proper adjustment and functioning as intended.
 - b. Equipment normally associated and approved for hand methods shall not be substituted for a finishing machine on mainline paving. Bridge deck finishing machines are not approved for placement of standard paving when a finishing machine is required, due to their lack of adequate consolidation equipment.
 - c. The finishing machine must be self-propelled and equipped with:
 - (i) Two independently operating screeds constructed with end wings to prevent concrete spillage over the forms.
 - (ii) A pan-type finisher-float for each paving train.

- d. If the screeds are the conventional reciprocating type which ride on the forms, check the end shoes for a worn surface. A poor slab surface with a valley along the form will result from worn end shoes.
 - e. A crown check of the screeds and pan-type finisher-float should be made by the contractor and in the presence of the inspector or project manager before the start of paving operation. To check the crown, raise the screed or float and stretch a 20-gauge piano wire or strong fish line across the bottom about 1 inch (25 mm) from the front face. Place a similar wire about 1 inch (25 mm) from the back face. Lower the screed or float down to the forms or to hardwood blocks and check the distance from the wire to the screed or float surface at every 12 inches (300 mm) across the roadway. The crown elevation at centerline on the back screed and float should be set about 1/8 inch (3 mm) high to allow for subsidence and shrinkage during setting of the concrete. This 1/8 inch (3 mm) may then be worked out to a normal crown in the 5 feet (1.5 m) each side of centerline. The front screed should be set slightly higher than the back so that concrete will be available for manipulation by the back screed.
 - f. *SSHC Subsection 601.02* provides that all spreading and finishing equipment in the paving train shall be equipped with scrapers or be constructed in such a manner as to keep the top of the paving form free of concrete.
10. Slip Form Paving Equipment
- a. Requirements are given in *SSHC Subsections 601.02* and *603.03*. The principal requirements is that the equipment be "capable of spreading, consolidating, striking off, shaping and float finishing the freshly placed concrete to the desired line, grade, and thickness in one continuous passage in such a manner that a minimum of finishing by hand methods will be required". This is a performance specification and the approval of the equipment depends on the end result on the current project or an earlier project. Appropriate equipment to provide internal vibration is very important. Automated electronically controlled subgrade machines are also required. The subgrade equipment must perform "in conjunction" with a taut reference line erected and maintained by the contractor.
11. Saws Used on New Pavement & Unbonded PCC Overlays
- a. *SSHC Subsection 603.03*, Paragraph 12 says sawing may begin when the contractor can accomplish the sawing without causing the concrete to ravel.
 - b. Sawing equipment heavier than 2000 lb (905 kg) will not be allowed on pavement with less than 18 hours age regardless of pavement thickness. Span saws with a mass of 8000 lb (3620 kg) or greater are not to be used on pavements of 175 mm or less design thickness without approval of the Project Manager and Construction Division. Span saws can be utilized on pavements greater than 7 inches (175 mm) design thickness after pavement has a minimum age of 18 hours.
 - c. The contractor shall provide sufficient sawing equipment to produce the sawing schedule required in the specifications or special provisions.

Standby saws should be provided. If the sawing schedule is not maintained, uncontrolled cracking of the slab will occur.

12. Miscellaneous Equipment

- a. Master Straightedge - The contractor is required to furnish and keep in a convenient place a master straightedge, made of 150 mm (6 inches) steel channel at least 10 feet (3 m) in length for the purpose of checking the straightedges at any time during the progress of the work. A sufficient number of straightedges shall be kept in readiness so as not to delay the paving operations.
- b. Water Supply Equipment - Check over the water supply equipment with the contractor's superintendent. Be sure that it is adequate.
- c. Forms - Forms shall be of metal and of a depth equal to the edge thickness of the pavement. Visually inspect the forms. Forms which are bent enough to produce uneven alignment or a poor riding surface should not be used until straightened. Flexible metal or wood forms should be used on curves having a radii of less than 100 feet (30.0 m). See *SSHC Subsection 603.03*.

13. Accumulation of Materials in Transporting Vehicles

- a. The contractor should periodically clean and flush all transporting equipment such as transit mixers, agitators, and wet batch trucks, to prevent accumulation of hardened concrete in any compartment. This also includes central plant mixing equipment. Frequent inspection of transporting vehicles and hoppers should help assure prevention of accumulation and build-up of hardened concrete.

602.00 PORTLAND CEMENT CONCRETE PAVEMENT SMOOTHNESS

602.01 GENERAL

602.02 EQUIPMENT

602.03 CERTIFICATION AND INDEPENDENT ASSURANCE TESTING

602.04 PROFILOGRAPH TEST PROCEDURES

- 1. See *SSHC Section 602* for profilograph procedures.
- 2. When the contract Special Provisions require the smoothness of the concrete pavement to be tested by measurement with the profilograph, it is necessary and a requirement of the Provision that the thickness cores be taken after to any surface correction (grinding) by the contractor.
- 3. Since the thickness cores are taken by personnel from the Materials and Research Division (Lincoln), it is necessary they be kept posted as far in advance as possible when the coring must be done. It is generally preferable to do the coring prior to opening the pavement (segments in some cases) to traffic. Accordingly, prior planning is necessary and shall be accomplished by the Project Manager. Contact the Materials & Research Quality Assurance Section.

602.05 EVALUATION

602.06 PAVEMENT SURFACE CORRECTION

602.07 TRAFFIC CONTROL

602.08 METHOD OF MEASUREMENT

602.09 BASIS OF PAYMENT

603.00 CONCRETE PAVEMENT

603.01 DESCRIPTION

1. Concrete pavement is a surface course composed of Portland cement concrete. It may be constructed on a prepared subgrade, a stabilized fill or a granular foundation course.
2. The production of high quality concrete pavement requires a very close control of all phases of the work. The Project Manager and inspectors assigned to concrete pavement projects should become thoroughly familiar with the construction details outlined in *SSHC Subsection 603*, and the material details given in *Sections 1002 to 1027*.
3. The essentials to observe in this type of pavement construction are:
 - a. Certified Plant Technician is available. Accurate proportioning and control of water, aggregate, cement and admixtures in accordance with the approved mix design.
 - b. Accurate control of the mixing time of the mix.
 - c. Prevention of segregation in the concrete.
 - d. Adequate amount and proper spacing of finishing equipment.
 - e. Properly trained equipment operators and finishers.
 - f. Proper curing.
 - g. Timely sawing of joints.
4. PCC Pavement Pre-concreting Conference
 - a. On all projects involving PCC pavement, the Project Manager and inspectors should meet with appropriate contractor and supplier personnel to discuss concrete production and pavement placement quality issues before any materials are placed. When ready mix concrete is used, the ready mix producer should also attend.
 - b. For the various types of work, the following items should be covered:
 - (i) Approvals and required quantities of aggregate and cement, class of mix, time and rate of delivery, percent of air, slump, batch weights, volume per truck, total quantity required, preparation of delivery tickets, testing arrangements, procedures in case of load rejection (air can be increased), responsibility for setting batch weights and amount of admixtures, placing, finishing and curing arrangements, and personnel work assignments.
 - (ii) Adverse (cold or hot) weather plan of action.
 - (iii) Settings and condition of paving equipment, dust control, subgrade treatment, procedure for checking steel placement, utility and street return box outs, heading-up equipment, joint sawing and cleaning, joint sealing, rain damage prevention, and cold weather protection.

- c. Only one preconcreting conference is considered necessary for thoroughly discussing the work and responsibilities and duties of all involved in the project. On small projects it may be possible to include a preconcreting conference with preconstruction conference.

603.02 MATERIAL REQUIREMENTS

- 1. Composition of Concrete (*SSHC Section 1002*)
 - a. The plans or special provisions may offer the contractor a choice of various classes of concrete. *SSHC Section 1002* lists the classes of concrete used in Nebraska road construction. If a choice is allowed, the contractor is required to advise the Project Manager of the class of concrete to be used. This notification must be given prior to construction. The Materials and Research Division should be consulted in regard to problems of concrete composition. Table 1002.02 shows authorized mix proportions for the classes of concrete.
 - b. Material Inspection - The production of a high quality concrete requires careful control over concrete materials at the batch plant. The inspector must be prompt and accurate to insure quality concrete.
 - c. *SSHC Sections 601, 602, and 603* contains requirements for concrete pavement construction. The Project Manager and inspectors must familiarize themselves with these requirements and insist that materials be tested and approved before being incorporated in the work. The frequency of sampling, testing or submitting of material samples to the Central Laboratory and the procedures to be followed are covered by the Materials & Research [*Materials Sampling Guide*](#).
 - d. Field Testing Laboratory - *SSHC Subsection 105.03* requires the contractor to furnish a field laboratory building meeting certain specific requirements for the type required in the contract. The Project Manager should document compliance for the laboratory's condition in the FCAC Form, Field Lab Compliance, and notify Contractor of any problems.
 - e. Admixtures - *SSHC Section 1002* states that "only admixtures authorized by the contract documents will be permitted for use in Portland cement concrete". Since the various materials constituting admixtures can have a profound effect on the characteristics of the hardened concrete, extreme caution is justified. (See *SSHC Section 1007* for more information on admixtures.)
- 2. Concrete Strength
 - a. The random coring program is the primary strength acceptance criteria for concrete pavement, with the exception of small independent placements. The strength criteria for the small independent placements will be based on cylinders. At a minimum, two cylinders are required for strength acceptance of the small placements. However, it is strongly recommended to make six additional cylinders.
 - b. Cylinders for opening strength are required of all pavements. A minimum of eight cylinders should be made. These test cylinders are then tested at ages of 7, 10, 14, and 28 days. However, the Contractor may make requests for opening strength breaks at ages less than 7 days. Once the

minimum required strength is achieved, that value can be used for acceptance (provided the test age is less than 28 days) and remaining cylinders discarded.

- c. If minimum required strength is not achieved during the opening strength testing, (prior to 28 days) a set of two cylinders must be saved for the 28 day compressive test for acceptance.

3. Concrete Sampling Locations

- a. Concrete samples shall be collected from at least three different portions of a batch after it is discharged, whether mixed on site or central mixed. Sample location point shall be after plastic concrete has been placed on the grade, either by direct depositing from a batch truck or by use of a placer/spreader machine. On slipform paving projects, optimum sample location is between placer/spreader and slipform paver machines. Care should be taken to avoid sampling concrete that has been vibrated manually or mechanically. Samples should be taken at locations within the batch that appear to be representative.

4. Testing Procedures

- a. When making test specimens, sample should consist of about 1 ft³ (0.03 cubic meters) and should be remixed a minimum amount by use of a shovel to ensure uniformity. For routine air and slump tests, smaller samples may be used.

5. Air Entrainment in Plastic Concrete

- a. *SSHC Table 1002.02* shows the required percent of entrained air needed in concrete paving mixes.
- b. Slipform paving equipment can sometimes cause a loss of entrained air. If a contractor is consistently running near the required minimum air content, the contractor should be advised to increase amount of air entraining admixture that is supplied to the mix at the paving plant.

6. Ready Mix Concrete

- a. Each truck load of concrete for a paving project must be identified by plant ticket.
- b. Required Information:
 - (i) The ticket must show plant name, contractor, project number, date, quantity, class, and time batched, water in all aggregates, water added, and total allowable water and water/cement ratio calculation.
 - (ii) Any water added other than at the plant to the mix must be documented. Aggregate moisture tests must be made frequently to insure uniformity in concrete consistency. The field staff should advocate to the contractor to take into consideration temperature changes, wind, production rates, deliveries, stockpile management, etc.

7. Concrete Discharge Times
 - a. To insure that quality concrete is incorporated into pavement maximum discharge times have been included in *SSHC Subsection 1002.03* for both continuous agitation (agitator trucks) and non-agitated trucks (dump trucks).
 - b. These discharge times should be verified at least once during each day of normal paving. These verifications should be recorded in project field books. During hot, dry, windy weather, maximum time limitations listed in specifications are critical limits set to insure that quality concrete is being placed and incorporated into project.
 - c. The nomograph in *SSHC Figure 711.01* can be used as a guide to determine the current evaporation rate.
8. Miscellaneous Material Requirements
 - a. Concrete with a low air content shall not be incorporated into work. Only one addition of air entraining admixture is allowed at the site. (See *SSHC Subsection 1007.03*)
 - b. Concrete with a high air content should not be allowed to be incorporated into work except under extreme circumstances. If low compressive strengths result, the concrete may be required to be removed and replaced.

603.03 CONSTRUCTION METHODS

1. Subgrade General
 - a. Make sure that the grade is always drained. There should be no areas where water can pool.
2. Preparation of Subgrade
 - a. Compaction Requirements - The subgrade compaction requirements will be shown in the plans. When a granular foundation course is not to be constructed, the upper 6 inches (150mm) of subgrade shall be compacted to at least 3 feet (900 mm) beyond the edge of the proposed pavement and this should be shown in the Plans. The crown and elevation of the subgrade will be established by means of trimming, as described in *SSHC Subsection 302.03*.
 - b. Subgrade Cross Sections - After completion of the Subgrade preparation items, cross-sections should be taken and recorded on a data collector.
3. Foundation Course
 - a. Construction Requirements - Foundation course, when required in the plans, is to be constructed according to *SSHC Section 307*.
 - b. Protection of Foundation Course - The contractor should be advised that the protection of the foundation course from rainwater is one of the most important features connected with concrete pavement. Ahead of the placing operation, holes should be opened beneath the pavement forms to drain the water off the subgrade. Trenches should also be cut through any shoulder dirt outside the form line to carry the water away. In case of

- rain, such precautions will protect the foundation course and earth subgrade from standing water and may prevent saturation of the material.
- c. Behind the finisher, protection of the foundation course beneath the previously laid slab is even more critical. During rains, water running off the pavement works under the bottom edge of the slab and washes out the foundation course. Even on very slight grades the force of the water soon becomes strong enough to wash out the entire depth of the foundation course from beneath the edge of the pavement. This may be in a strip of variable width, and may amount to as much as 3 feet (1 m).
 - d. To prevent this damage to the foundation course, the contractor may push an earth windrow against the edge of the slab sometime after the curing compound has been applied. Washing away of the foundation course is not usually a problem on slab which still have the side forms in place. However, it will occur on steeper grades unless the water is diverted over the shoulder by dikes at frequent intervals.
 - e. Immediately after any rain, inspect the foundation course along the slab edges.
 - f. Cross Sections and Thickness Measurements - Cross Sections should be taken on the completed subgrade and later, on the completed foundation course.
 - g. Thickness measurements should be made at the time of testing for density.
4. Grades on Drives in Cities
- a. An attempt is made to standardize grades for residential drives constructed in conjunction with urban paving projects. Standardization reduces property owner complaints about their cars dragging when using their drives. A special design will be shown on plans for commercial drives such as filling station drives. The Design Office uses a standard design detail for driveways as well as a typical automobile template to check driveway cross sections.
 - b. If field conditions necessitate a change in driveway grades, vehicle clearances should be checked using typical automobile template dimensions. This can be accomplished by using a scale model template to check plotted grades for new driveways. Keep in mind that there are exceptions to all rules and there may be cases when more clearance may be required than indicated by template. In critical locations it may be necessary to contact the Roadway Design Division for help in determining a revised driveway design.
5. Protection of Pavement (*SSHC Subsection 601.02*)
- a. Wheels of finishing equipment operating on previously placed pavement shall be rubber faced. Track propelled equipment should be equipped with rubber protective pads on crawler tracks or tracks shall travel on cushions of wood or belting. The near edge of wheels or tracks shall not be closer than 3 inches (75 mm) from edge of pavement. Provisions must also be made to prevent the screed from damaging the edge of existing pavement surface.

6. Operating Finishing Equipment on Previously Placed Concrete in Multiple-Lane Construction (*SSHC Subsection 603.03*)
 - a. Concrete pavement finishing equipment may be permitted to travel on an adjacent lane after 14 days or when concrete test cylinders indicate that the pavement has attained a compression strength of 3000 psi (21 MPa).
7. Surface Cleaning
 - a. When placing a lane adjacent to completed pavement any spillage or flow of concrete slurry on the surface of existing pavement must be broomed off prior to hardening. This helps prevent the transverse groove from being filled with concrete which would reduce the effectiveness of the texture.
8. Material Inspections
 - a. *SSHC Subsection 603.04* explains how materials for concrete pavement shall be measured. Check in SiteManager that the plant has a current certification and Policy 7 of the [Materials Sampling Guide](#).
 - b. The following is a discussion of measuring and handling concrete materials as set forth in *SSHC Section 1002* and [Materials Sampling Guide](#).
 - c. Stockpiles - It is the contractor's responsibility to avoid harmful contamination, segregation or excessive degradation in placing or removing aggregates from the stockpile. Although the specifications do not specify the methods to be used by the contractor in stockpiling aggregates, the Project Manager should be aware of the method to be used and should alert the contractor when chosen methods may produce unsatisfactory results. All aggregates are to be stockpiled separately. (*SSHC Section 1033*)
 - d. If a bulkhead is used in separating the individual aggregates it should be high enough to prevent intermingling of the aggregates. Aggregates which become intermixed shall not be used. Building a stockpile properly in horizontal layers tends to reduce the tendency to segregate. If the material is being dropped from a considerable height, the stacker should be equipped with a rock ladder or tremie to reduce the falling impact and prevent segregation. A brisk wind blowing through the falling aggregates will deposit the fines on the lee side of the pile while the larger particles remain on the opposite side. It is the contractor's responsibility to provide the specified gradation of the aggregate entering the mix. When crawler tractors are used on gravel stockpiles, the contractor must clean all caked dirt and mud from the track ways and from beneath the machine before running it on the pile. Crawler equipped dozers or end loaders must not be allowed to damage aggregates in the stockpiling areas.
 - e. If the aggregates are hauled to the project in railroad cars, burlap and boards used to chink cracks in these cars become mixed with the material. A grizzly with a maximum of 6 inches (150 mm) square openings should be placed on top of the aggregate bins to catch foreign material previously missed. They should be cleaned at least twice daily to prevent forcing the foreign material through the grizzly openings and into the batch.

9. Batching Inspections

- a. General - The importance of proper batching inspection cannot be over-emphasized since proper proportioning of materials is one of the major steps in obtaining a satisfactory pavement. The plant inspector and their assistants carry out the inspection at the batching plant. The following items should be closely inspected during the progress of the work:
- (i) Be familiar with the physical characteristics of aggregates, design mix proportions, the method of determining batch quantities, scales operation, yield, effective water, cement factor and the procedure for adjusting proportions and yield when using air entrainment.
 - (ii) Calibration of scales and measuring devices, and the systematic and regular checking of scale settings for batches to assure proper quantities are being dispensed. (Scale settings are not to be made by the inspector since this is the contractor's responsibility.) The NRMCA, Quality Control Manual, Section 3, Plant Certification, outlines the steps required of the contractor in calibrating the scales and checking their sensitivities.
 - (iii) Sampling and testing is as indicated by the Materials & Research [Materials Sampling Guide](#).
 - (iv) Water of doubtful quality must be tested and accepted prior to incorporating in the mix. The intake end of the pipe or hose used in pumping mixing water from a stream or standing body of water should be covered with wire mesh and located so that no foreign matter will enter. Hauling of mixing water should be done in clean, covered containers. Assurance of using acceptable water is the responsibility of the plant inspector for central or ready mixing and the responsibility of the slab inspector for on-the-job mixing.
 - (v) Some scale bins do not always empty themselves after each batching cycle. The inspector should check the cement and aggregate bins for cleaning frequently at the beginning of the job. If the cement becomes packed in the corners of the scale bin, the correct mass will be shown on the scale but something less than the full mass will actually reach the batch. This condition can be corrected by rounding out such dead areas in the bin design or by means of vibrators attached to the bin sides.
 - (vi) When changing scale weights for batch correction in the aggregates, be sure that the set screws, holding the counterweights in position on the beam arms, are firmly tightened by the operators. Constant vibration around the plant tends to move these weights, causing an incorrect amount of aggregate to enter the batch.
 - (vii) If rain comes at any time while the aggregate bins are loaded, the water will collect in the material at the bottom of the bins. Two or three truckloads of each size aggregate should be taken from the bins and hauled back into the stockpiles before batching begins. When this is not done, the moisture content of the first few

batches will be excessive and sloppy concrete will result at the mixer. Many contractors allow the bins to empty at the end of the day for the above reason.

- (viii) All working parts, particularly the knife edges, should be in good condition, free from friction, readily accessible for inspection and cleaning, and protected from falling or adhering material. Dash pots should be clean, regularly inspected and filled, and free from friction. Elements of the lever system must not rub against other elements or framework of the plant. All nuts that might work loose in operation should be protected by locking devices. The scale container and closing devices should be tight against leakage and the plant should be carefully leveled and on a firm foundation.
- (ix) At least once each shift the scale should be checked by halting the measuring cycle with a normally measured batch in the scale hopper and noting the precise scale reading. The addition of four standard 50 lb (25 Kg) weights to the hopper should result in an exact indication of an additional 200 lb (100 Kg) on the scale dial or beam balance. Erratic measurement due to binding scales can be detected in this manner.
- (x) Require that central-mixed concrete be hauled in vehicles meeting specification requirements and in a manner to avoid segregation and be delivered at the site with proper consistency and workability before the concrete starts to take its initial set. Require agitating type trucks if batch is to be held in trucks more than 30 minutes.
- (xi) When the yield is found to vary considerably for no apparent reason, check accuracy of the scale. In addition to the methods of checking described above a quick method is to measure a loaded and tared batch truck on platform scales. Erratic measurement due to binding scales can also be detected in this manner.

10. Cement Hauling Inspections

- a. The inspector will observe the measurement of all batches and see that the beams balance after the discharge of each batch. If a springless, dial-type scale is used, the pointer must return to zero.
- b. The inspector must also keep a complete, accurate record of all cement received, used and wasted. This record will be used to determine the cement factor being obtained and to verify the correct proportions of cement to aggregates. The record is kept in the "cement notebook" and should consist of:
 - (i) A complete index
 - (ii) Scale calibration record
 - (iii) Daily cement record
 - (iv) Cement car record
- c. The cement car record consists of statistical information concerning every car of cement used on the project. The railroad net mass of each car may

be obtained from the freight office or from the contractor's freight bills. The remainder of the information is a record of the use of the cement on the project.

- d. The cement used at the plant shall be checked against the cement required by the total number of batches or cubic meters mixed. These checks are to be made during the progress of the work in accordance with the procedures outlined herein. The first or initial check of cement used against the cement required should be made at or near the close of the first or second full day's paving operation, and at least before unloading the 11th carload of cement. The initial and successive cement checks should be made between carloads and with cement silo and storage or service bins completely empty.
- e. If the initial check shows that less than 99 percent of required cement was used, the calibration and operation of all measurement and proportioning equipment, and the proportioning of aggregates and cement should be immediately and thoroughly checked. A second "empty bin" check of cement used should then be made at or near the close of the first or second full day's paving operation following and before unloading the 11th carload of cement used after the initial check.
- f. If the initial check or succeeding checks of cement used show more than 99 percent but less than 100 percent of required cement used, a succeeding "empty bin" check shall be made at or near the close of a day's paving operations or not later than the 50th carload of cement used after the previous check, whichever involves the greater quantity of cement. The contractor can make "empty bin" cement checks at more frequent intervals if they so desires and our Project Managers should lend their full cooperation in making such checks.
- g. It is realized that in the case of paving projects obtaining concrete proportioned at commercial ready-mixed plants, it is usually impossible to make accurate, "empty bin" checks of the cement used. Accordingly, it is extremely important that the project manager and the paving plant inspector make certain that the inspection of the measuring and proportioning is full time and fully adequate; that the scales measuring the aggregates and cement are accurate; and that the procedures are conducted in a careful and precise manner so as to insure the correct proportioning of aggregates and cement.
- h. In the inspection of the cement measuring operations at either commercial ready-mixed concrete plants or proportioning plants, the Project Manager and the plant inspector should make certain that air pressure in the cement delivery and storage system is not affecting the cement scale and cement measuring operation. It has been found that in certain proportioning plants, if the service bin and the scale hopper for cement are not adequately vented, air pressure buildup in the scale hopper will cause some under measurement of the cement. This can be positively checked by introducing cement into the hopper until the scale indicates the correct amount for a batch and then hold up the operation with the scale fully loaded for a short period of time sufficient to void any air pressure in the cement weighing hopper. If the cement scale is functioning properly, the scale beam and dial indicator will remain

stable. If air pressure is affecting the measuring operation, the cement scale beam and dial indicator will indicate a decreased mass of cement as the air pressure dissipates. It is important that this item be checked periodically on all proportioning plants using air pressure to transfer or move cement within the plant.

i. Checking the Interlocked Automatic Batching Controls

- (1) During regular batching operations, compare the dial reading at cut off with the cut off settings.
- (2) During a measuring cycle with the plant in automatic operation ask the operator to move the control lever from charge position to discharge position. If the discharge gates open before the weighing cycle is complete, the system is not functioning in a proper manner.
- (3) During the discharge cycle, before the discharge gate is closed, place or suspend 50 lb (25 Kg) on the hopper. If the discharge gate can be closed and the bin gates opened automatically at the end of the discharge cycle, with the 50 lb (25 Kg) mass still in place, the interlock system is not functioning properly.
- (4) During a normal batching cycle, ask the operator to set one bin gate for manual control, closing it early so that less than normal mass is drawn from that bin. Then ask the operator to return to operation by automatic control, with the light mass batch in the hopper. If the discharge gate opens, the controls are not functioning properly. Repeat this operation with the bin gates for each of the ingredients of the batch.

11. Mixing and Hauling

- a. Methods - Several combinations of methods for mixing and hauling of concrete for pavement construction can be used:
- b. Since the procedures to be used by the contractor may vary, the Project Manager on each project should assign definite division of responsibility to the plant inspector and the slab inspector before paving operations are started.
- c. Inspection - The following paragraphs include important mixing and hauling inspections:
 - (i) Check the time on the mixer at least twice daily.
 - (ii) Check for uniformity of batch consistency. Non-uniformity may be caused by any of the following:
 - (1) Leaky mixer valves. Indications of this condition are wet batches when mixed for periods longer than the normal interval.
 - (2) Double pulling of water valve. Watch the mixer operator for correction of this condition.

- (3) Moisture change in the aggregate. Loader operator may be dipping into aggregate stockpile which has not drained sufficiently.
 - (4) Empty AEA supply container or partially clogged supply tube to mixer drum. Another indication of the failure of the AEA supply is free water on the finished slab. The plant foreman should be made responsible for delegating a reliable man to fill the AEA supply tank each day or as often as necessary. A leaking valve on the AEA dispenser will also cause trouble, producing a batch with too much slump and too high an air content.
- (iii) Wash water in transit-mix trucks, if being used, should be completely discharged. Quality concrete work is dependent on the uniform consistency of the concrete mixture being used and will only result when good control of the water-cement ratio is maintained. Our specifications do permit the use of wash water as a portion of the mixing water when accurately measured and taken into account in determining the quantity of water to be added. However, it is very difficult, if not impossible, to accurately measure wash water remaining in the drum, and this procedure should always be discouraged.
 - (iv) Mixing is controlled either by a specified time, or number of revolutions at a specified revolutions per minute. Regardless of the method used for controlling proper mixing, it shall begin after all ingredients are in the mixer, including water. Close cooperation is required between plant and road inspectors to assure proper mixing time or number of revolution is being observed and that concrete is placed within the designated time limit.
 - (v) Truck mixers should be checked to assure that there is no leakage from the water tank into the mixer.
 - (vi) Concrete, when it leaves the chute of a truck mixer or truck agitator, tends to segregate. Segregation can be corrected by providing a baffle at the end of the chute to cause the concrete to drop vertically.
 - (vii) A satisfactory method of extending the actual haul in transit-mix operations is to add the cement, not at the batching plant, but a point closer to the work. During the haul between the batching plant and the point at which the cement is added the mixer should not be revolving as otherwise the aggregate would be subjected to unnecessary grinding action.
 - (viii) The specifications provide that the truck mixer or agitator shall be capable of delivering and discharging the concrete in a thoroughly mixed and uniform condition. According to ASTM, concrete that has not been thoroughly mixed will have a slump test value that differs by more than 2 inches (50 mm) when taken at approximately the 1/4 and 3/4 discharge points.

- (ix) *SSHC Subsection 1002.03* requires the contractor to have a procedure to issue a ticket to the driver of each load of concrete delivered to the project. In addition to the requirements shown in the specifications, the concrete ticket handling procedure shall include the following:
 - (1) The concrete ticket for the first load of concrete each day will indicate the number of gallons of water that can be added without exceeding the maximum specified. The maximum number of liters will be indicated on subsequent tickets as changes occur.
 - (2) Any additional water added to the mixer, at the site of work, will be recorded in gallons on the ticket by the driver. If additional mixing water is required, a minimum of 20 revolutions of the truck mixer drum at mixing speed shall be required before discharge of any concrete.
- (x) Truck mixers shall be randomly checked against ASTM C 94. The concrete shall be mixed for not less than 50 nor more than 100 revolutions at mixing speed. It is further required that additional mixing in excess of 100 revolutions be at agitating speed and the change from mixing to agitating speed shall be done by the truck mixer operator at an intermediate station established at a point along the route by the Project Manager. Random checks are to be made often enough to assure compliance, and in general should consist of from one to four checks daily based on the quantity of concrete produced. These random checks shall include the following:
 - (1) Field personnel shall check that the Contractor sets the zero setting of the revolution counter after charging of batch and the proper drum mixing speed.
 - (2) Placement inspection personnel shall check the number of revolutions recorded on the counter for compliance with the specifications.
 - (3) The random checks shall be recorded in the field notebooks.
- (xi) The temperature controls in SSHC Section 1002 should be strictly enforced.
- (xii) Regardless of whether concrete is mixed in site mixers, stationary mixers, or truck mixers it is the responsibility of the slab inspector to assure that it is properly mixed and meets the requirements in regard to slump, air content, uniformity, and desired workability when delivered to the subgrade. Wet and dry batches should be avoided and the slump held to within very narrow limits, normally not exceeding ½ inch (12.5 mm) variation.
- (xiii) The schedule of delivery of ready-mixed concrete is sometimes a problem due to the long haul and the interference of other commercial traffic. The Project Manager should check this matter carefully with the contractor's superintendent. Sufficient hauling

units should be provided to assure a minimum time lag between the arrival of batches at the site of the work. In no case should this be longer than 30 minutes.

- (xiv) The two main faults with truck mixers and agitators is their inability to discharge low slump concrete and their tendency to hold back too much of the coarse aggregate until the last few cubic feet of the batch are discharged. Nothing can be done about the first of these faults, the second can be partially corrected by depositing the last increment of the batch at a point where it can be mixed into other concrete.
- (xv) Haul time and stand-by time frequently has an adverse effect on the consistency of truck-mixed or truck-agitated concrete. The batch becomes progressively stiffer as the time increases. The rate of stiffening is affected by the characteristics of the cement and aggregates, and by temperature. The 1 1/2 hours maximum mixing and agitating time allowed in *SSHC Subsection 1002.04* shall be reduced if undue stiffening is apparent. The stiffening process may be reversed by adding extra water either at the start or at the point of delivery. In either case the end result is the same, a higher water-cement ratio and lower quality concrete. Caution should be used in employing this method of retarding stiffening, and in no case should the total amount of the water per batch exceed the total allowed by the specifications.
- (xvi) In transit-mixed concrete, the inspector should examine the batch for cement balls. These usually are the result of the method of charging the water. If sufficient water, about 40 percent, enters the drum ahead of the aggregates and cement, cement balls will not usually occur. Most of the remainder of the water should enter with the cement and aggregates and the mixer should be rotating during the charging period.
- (xvii) When discharging transit mixers at the site of the work, the rate of discharge should be regulated by the speed of rotation of the drum and not by the size of the discharge opening.
- (xviii) Truck mixers shall be examined periodically for accumulation of hardened concrete. Any truck mixers showing such accretions or excessively worn pickup and mixing blade shall not be used.

12. Forms (Usually small paved areas.) (*SSHC Subsection 603.03*)

- a. Form Setting - After the foundation course has been properly compacted, the forms may be set. If the foundation course is low along the form line, additional material shall be placed and compacted before setting the forms in place. Forms shall be tamped mechanically. Form pins shall be long enough to penetrate the earth grade below the foundation course a sufficient depth to hold the form rigidly in place. If the project is in town, or in curb sections where drainage is a factor, form elevations should be checked with an instrument after the forms are set and tamped.
- b. Form Alignment Ahead of Paver - All forms should be inspected for alignment, elevation and adequacy of tamping immediately ahead of the

paver. This should be done far enough in advance to allow for correction of high and low joints or additional tamping if necessary. A smooth form line is an important factor in the riding quality of the finished pavement and should always be checked before placing concrete between the forms. Forms should be oiled to prevent sticking to the concrete.

- c. Check forms as necessary to verify they have not settled.
 - d. Form Removal - Forms should not be removed sooner than 12 hours after concrete has been placed. Care is to be exercised in this operation to see that the edges of the slab are not broken or otherwise damaged. The sides of the pavement slab should be covered with the curing compound within 30 minutes after removal of the forms.
13. Placing Reinforcing Steel (*SSHC Subsection 603.03*)
- a. Steel reinforcing bars and dowel bars are often supported by metal chairs or units of approved design but the use of mechanical placers (for dowels and tie bars) or a jig (for tie bar) is allowed. It is the contractor's responsibility to get approval prior to construction of dowel baskets of a type not shown in the plans or described in the special provisions.
 - b. The specifications allow machine placement of the longitudinal deformed tie bars in lieu of being supported by metal chairs. Tie bars must be installed at the spacing ($\pm 4"$) shown in the contract. The tie bar inserter must be located in the paving train so as to place tie bars prior to the placement of the wire mesh on reinforced concrete pavement, or prior to the passage of the first finishing machine on non-reinforced concrete pavement.
14. Tie-Bar Steel Inspection (*SSHC Subsection 603.03*)
- a. All paving contractors should place joint tie steel according to details in the plans. The following tie-bar steel inspection procedures will be required on all Portland cement concrete paving projects where centerline or lane line tie-bar steel in plastic concrete:
 - (i) Manually check location and depth of tie-bar steel in the plastic concrete behind slipform paver each day.
 - (ii) Using a magnetic locator (pin finder), verify location of tie-bar steel in hardened concrete every day.
 - (iii) Mechanically inserted tie bars (or tie bars installed using a jig) must be installed in a quick continuous movement to avoid creating a void behind the bar.
 - b. To insure compliance with proper joint design parameters, use the following minimum frequencies when checking rebar location:
 - (i) Once in morning and once in afternoon for tangent roadway sections check the location.
 - (ii) In at least three locations within all horizontal curve sections. These locations generally would be at the beginning transition, in the middle of the curve, and at the ending transition.

- (iii) For each inspection, at least two tie-bar steel locations within a panel should be checked.
 - (iv) Checks of any area with out-of-tolerance tie-bar steel (such as missing tie bars or tie bars installed too close to transverse joints) should be expanded so that extent of problem area is identified for retrofit correction. These areas should be determined on hardened concrete.
 - c. The checked areas of hardened concrete should not overlap previously checked plastic concrete areas.
 - d. Project inspector should document tie-bar steel inspection results in the Daily Work Report.
 - e. Minimum placement tolerances are as follows:
 - (i) Depth: $D/2 + 1$ inch (shallower), $- 1.5$ inch (deeper) ($D/2+25$ mm, -37 mm).
 - f. Angle: Minor variations are not critical as long as at least an effective length of 12 inches (300 mm) of tie-bar steel extends across joint.
 - (i) Lateral position, number of bars shall be as shown in the plans.
 - (ii) Joint deficiencies in lateral position and number should be evaluated by the Construction Division.
 - g. If previously mentioned inspection procedures discover out-of-tolerance tie-bar steel, the contractor has the following options to remedy the problem:
 - (i) Contractor may substitute a longer bar to better ensure an adequate length across joint.
 - (ii) Contractor may place additional uniformly spaced bars across joint.
 - (iii) Contractor may move the bar inserter uphill on the paver.
- 15. Inlet and Utility Accesses
 - a. Inlet standards show a portion of slab, or a portion of curb and gutter unit blocked out at the time of construction which is to be filled in later when the inlets are built. Since the inlets are usually sublet by paving contractor, the question of including this insert section as a part of the inlet has been brought up frequently.
 - b. When computing the quantity of pavement, designers consider all concrete work between the curb edges of pavement.
 - c. No deduction is made for insert sections which are blocked out and then formed when the inlet is built. These insert sections are blocked out to facilitate construction of inlet. Other areas of pavement or curb and gutter may be blocked out to prevent slowdowns of the paving crew because of special shaping requirements. Insert sections and areas requiring special shaping will be paid for as part of the pavement or curb and gutter quantities.

16. Box-Outs for Utility Accesses
 - a. Standard Road Plans provide for boxing out utility accesses in pavement. Clearance of the manhole ring below pavement grade shall generally be $\frac{1}{4}$ inch (6 mm). Care must be taken during paving process to avoid disturbance of the ring. The concrete roll in front of the screed as it passes over the ring should be removed and used to pack around the ring. This should prevent movement.
 - b. Box-out for utility accesses occurring in the form line should be three-sided with the end sections at 60 degrees with form and center section parallel with form. All three sides should be about 12 inches (300 mm) from the upper edge of the ring.
 - c. The ring should be set to the required grade and concreted-in when an adjacent slab is being placed. Special procedures may be necessary when incorporating some old utility accesses into new pavement as to whether a box-out is used or not. Particular attention should be paid if bearing support of the old structure is questionable.
17. Box-Outs on Slip-Form Paving
 - a. Contractors when slip-forming urban projects sometimes fill the inside area of box-outs for utility accesses and intakes with soil. This is to help keep the forms from moving and reduce the volume of concrete mix that is wasted during passage of paver over box-outs.
 - b. In some cases, the box-out is filled to a greater height than forms and soil becomes intermixed with concrete as paver passes over these areas. This results in contaminated mix being incorporated in pavement. To insure that the concrete mix will not be contaminated, the height of the fill inside box-out area should be 3 inches (75 mm) or more below top of the forms or a sheet of plywood may be placed over opening of box-out areas.
18. Placing and Spreading (*SSHC Subsection 603.03*)
 - a. General - The slab inspector normally has the responsibility for inspecting the placement and spreading of the plastic concrete in such a manner as to provide a structurally sound pavement with smooth riding qualities and to see that this work and the finishing is accomplished as required by the contract documents.
 - b. The paver, truck mixer or truck agitator should distribute the concrete evenly on the subgrade without displacement of reinforcing steel or joint material. Concrete dumped in piles can cause roughness. Do not overload one side of the spreader as the extra weight on one side of the machine may cause it to displace the forms. Centerline tie bars shall be placed carefully so that the centerline splits the bar. When expansion joints are encountered, concrete should be banked around both sides of all joint material by hand prior to spreading near the joint with the machine. The slab inspector shall see that none of the dowel assemblies or joint material is displaced during the placing and vibrating of the concrete.

- c. The quantity of concrete used should be checked by comparing the number of batches used with the number of cubic yards (cubic meters) required. These checks should be made at shutdown, mid-shift breaks and at other points providing a distinct check on batches used and such checks should be entered in the NDOT Form 85 "slab report". If measurements (such as subgrade, form settlement, slab thickness, and crown measurements) indicate the possibility of thin pavement, checks on the concrete quantities used should be made more often. When the pavement is placed in two layers, concrete quantity checks are difficult to make. However, using a little forethought and exercising good judgment, a fairly accurate check can be made without "evening up".
 - d. Batch volume underruns may be due to any of the following reasons and should be investigated immediately:
 - (i) High subgrade
 - (ii) Form settlement
 - (iii) Low crown
 - (iv) Excess mass from aggregate scale operator
 - (v) Wrong scale setting or slipping of counter weight at aggregate scale
 - e. Slab thickness and crown checks should be performed a minimum of three times each day. The slab thickness check shall be made by placing a thin piece of plywood or other suitable material of approximately 8" x 8" (200 x 200 mm) size at existing subgrade or foundation course level at three points along the transverse section, such as at the two one-quarter points and at centerline. After the finishing machine has passed over the selected location the thickness of the slab shall be measured at the three predetermined points. Crown checks shall be made directly back of finishing machine by the use of a taut line over blocks placed on the edge of the slab. The blocks should be of the same thickness as the height of the crown. The line should be drawn taut and lowered to the blocks and then moved back and forth in a sawing action. If the crown is correct, the taut line will leave a mark of approximately 18 to 36 inches (0.5 to 1 m) in length at the center of the slab. Generally, the contractor makes similar checks and these checks can be made in conjunction with their checking. All checks are to be made a matter of record in a field notebook.
19. Slip-Form Construction (*SSHC Subsection 603.03*)
- a. The pavement may be constructed by means of slip-form equipment conforming to the requirements of the *Standard Specifications*. Fixed form methods of construction are used on irregular or variable width sections which are not adaptable to slip-form construction; however, the use of a slip-form paver in conjunction with fixed forms is allowed.
 - b. The adequacy of the finished pavement constructed by the slip-form method is highly dependent upon proper setup of machine controls, , well maintained equipment and inspection procedures. The Inspector should be present when the Contractor performs their initial check of the

- hydraulic systems, vibrators, electronic readouts and drives. This should be done prior to each days paving.
- c. The paver is equipped with side forms to support the concrete laterally for a sufficient length of time during placement to produce pavement of the required cross section.
 - d. Smooth pavement begins with a uniformly stable subgrade and foundation course which have been constructed, trimmed and maintained at true line and grade during the time prior to the passage of the slip-form paver. These courses shall be constructed to conform to the typical cross sections shown on the plans and of sufficient width to include the trackways for the subgrade machine or machines and the slip-form paver.
 - e. Vigilant inspection is required of all construction operations to insure that they are in accordance with the requirements of the specifications. Various factors essential to production of sound, smooth and durable slip-form pavement are listed below:
 - (i) Use of aggregates meeting the gradation production tolerances listed in the Contractor's approved mix design.
 - (ii) Accurate accounting of the batch proportions (by the producer) with adjustments for moisture content of aggregate.
 - (iii) Use of the proper quantity of mixing water required to produce a plastic, workable concrete mix of uniform consistency that prevents edge slumping.
 - (iv) Introduction of air entraining admixtures into mix to create the required air content within the prescribed limits.
 - (v) Thorough mixing for required minimum length of time.
 - (vi) Proper placing and consolidation of the concrete.
 - (vii) Correct placement of steel reinforcement and dowel joint assemblies.
 - (viii) Strict compliance with required curing methods.
 - (ix) Timely sawing of transverse contraction joints.
 - (x) Restriction of loads on pavement until it has gained the required strength.
 - f. Control of line and grade for both the subgrade and foundation course work is accomplished by using a reference line set from the offset hub line. It is supported and tensioned to prevent any measurable sag or transverse movement. The machines have sensors which use the reference line for alignment and automatic grade control. The use of these automatic controls is analogous to the form line in the conventional method. The maintenance of the cross-section of the subgrade or foundation course to the plan elevation, controls the thickness of the finished pavement. Once the subgrade or foundation course has been completed to plan requirements of line, grade and stiffness, it is extremely important that it be protected, particularly the tracking path area, until the passage of the slip-form paver.

- g. For slip form paving using string-less technology the reference line is virtual and is contained in the 3-D model. It is good practice to obtain (from the Contract's 3-D model) the profile elevations at key locations (such as existing pavement or bridge deck match points (tie ins), vertical curves, inlets, block-out forms, etc...). The installation of paving hubs can be a valuable tool if key location are more than 500 feet apart.
 - h. The concrete is delivered to the paver in any conventional manner. When possible, keep concrete trucks off the subgrade. The fresh concrete is deposited on the subgrade, by uniform distribution of batches, just ahead of the paver. The uniform distribution of the batches is very important in slip-form paving. For the purpose of metering the correct amount of concrete for the full paving width to the main screed, pavers of this type are normally equipped with an initial strike-off blade provided with power travel fore and aft independent of the forward travel of the paver. Some pavers are equipped with augers which effectively meter the fresh concrete to the main screed. The forward speed of the paver shall be adjusted to the average progress of the concrete production and delivery in order that operations shall be as continuous and uninterrupted as possible.
 - i. Because of physical limitations as to the mass of the machine and of the relatively large screed area, the importance of using concrete of proper consistency and uniform distribution is extremely critical. Large piles of concrete or dry batches will cause the paver to "float" or lift above the true grade and result in a high area or bump. Wet batches cause low spots and edge slump and irregularity.
 - j. The concrete, for the full paving width, shall be effectively consolidated by internal vibration with transverse vibrating units of a series of longitudinal vibrating units. The paver extrusion plate or screed shall extrude the concrete under load, properly shaping and compacting the concrete into a dense, stable mass to assure that the concrete remains stable, with a minimum amount of slumping after the passage of the paver. Some pavers may have more than one device for the screeding operation.
 - k. The finishing and curing shall be in accordance with *SSHC Subsection 603.03*, Paragraphs 8 and 11. The requirements for surface texturing and curing may be accomplished by accessories mounted on the self-propelled float finisher.
20. Surface Finishing
- a. General - The traveling public judges your pavement job by its riding qualities. Careful inspection of the finishing operation will assure a surface which will receive public approval.
 - b. The intention of the specifications is that manipulation of the concrete during finishing should be held to a minimum. Overworking tends to bring water to the top. This is detrimental to the wearing surface and to the strength of the concrete. Hand finishing, unless allowed by the special provisions, can be used only in cases of emergency on normal width pavement or on narrow or variable width sections where mechanical methods are impractical.

- c. Machine Finishing (*SSHC Subsection 601.02*) - The minimum requirement of mechanical finishing equipment prescribed by the specifications is:
 - (i) Self-propelled concrete spreader
 - (ii) Self-propelled finishing machine equipped with a pan-type finisher-float
- d. On high production pavement projects [over 150 feet (45 m)] of pavement per hour or when more than one concrete mixer is used), an additional finishing-machine without the pan-type finisher-float is recommended. The goal of this paving train is to adjust the forward speed of the final finishing machine (equipped with the pan-type finisher-float) to the concrete production, so as to provide an uninterrupted strike-off operation. The combination float-finisher is designed for a one-pass operation. Concrete should be accurately metered to this machine. The spreader of the auxiliary finisher (if required) should leave enough concrete for a uniform roll of approximately 4 inches (100 mm) for the front screed. This screed in-turn should be tilted enough to allow 2 to 3 inches (50 to 75 mm) roll for the rear screed. The pavement surface is then trimmed to the desired grade and crown by the rear screed. The pan float will normally be set almost flat longitudinally with the roadway and should just make contact with the pavement surface.
- e. Transitions - Some pavements are designed with a tangent crown, which shall be removed gradually for superelevated curves. The distance in which the crown is to be removed will be shown on the standard or special plans. This will require adjustments on both the spreader and the finish machine or machines. The operation of this equipment should be synchronized so that the same amount of crown is being removed, or replaced, by each machine at any given point in the transition.
- f. The transverse finishers in use usually have a single adjustment point at one end of the screeds and pan float which permits running the crown in and out on superelevated curve transitions.
- g. The distance in which the crown is removed may be increased or decreased over the distance given on the standard plan, if the Project Manager determines a change is beneficial. The crown is removed in the transition distance in equal increments. The number of increments to be used should be divided into the transition distance to obtain the length between each crown change. Set a stake in the shoulder along the form line at each of these points, where it will be visible to the machine operators. The pavement foreman should delegate experienced personnel to "crank out" the crown on the screeds and float.
- h. Straight edging (*SSHC Subsection 603.03*) - After completion of the mechanical finishing and while the concrete is still plastic, laitance and surplus water shall be removed and the surface shall be made true and smooth with approved 10 foot (3 m) straightedges supplemented by such floating as is necessary to eliminate all depressions and irregularities. Straightedges shall be set parallel to centerline and shall be lapped 1/2 their length in each successive position. High areas shall be removed and depressions shall be filled with fresh concrete and consolidated by

floating with approved hand floats. Straightedge testing shall be continued as necessary until all irregularities have been found to be satisfactorily corrected. Straightedges should be checked against a straight steel channel as needed. When using slip form construction, straight edging will generally only be required at the beginning and ending of the daily placement. (Also see *SSHC Section 601 Paragraph 10.*)

- i. At longitudinal contraction joints along old pavement or companion lanes, care must be taken to prevent the newly finished surface overhanging the top of the adjacent slab. This can be accomplished by the flat finishers "dragging off" the excess concrete with a straightedge pulled longitudinally along the joint after the initial subsidence of the fresh concrete. This "pushing up" of the fresh concrete against the previously laid slab is especially noticeable when the crown elevation of the fresh concrete is higher than that of the lane already in place. (This also channels water into the joint and shall be avoided.) If this is not corrected, it will be very annoying to traffic when changing lanes and may even become a traffic hazard. Edgers must not depress this joint. Competent workers shall be detailed to the finishing and edging of this part of the work.
- j. Drag Finish - The surface of the pavement shall be given a final finish by means of a wet burlap, carpet or canvas drawn in the longitudinal direction. The drag should be of sufficient width so that the entire slab can be textured in one operation. It is required to be supported from a mandrel which is often attached to the rear of the belting machine or the self-propelled float finisher when slip forming.
- k. Expansion joints, if any, should be edged at this time taking care to remove all concrete from the top of the joint leaving a full 1 inch (25 mm) wide opening. Workers should be cautioned not to bear down on the edger as this will depress the concrete and leave a rough joint. Edger marks at the joints and the edge of the slab should be removed with a small piece of wet burlap, leaving the surface with a uniform texture and appearance. Straightedge all joints after edging.

21. Use of Water in Finishing Concrete

- a. *SSHC Subsection 603.03* does not allow concrete finishers to apply water to surface of pavement to aid in finishing of concrete except limited amounts with an orchard sprayer. Any additional water added to surface of fresh concrete increases water/cement ratio of mortar and adversely affects air content. This results in a less durable matrix and concrete surface is more prone to early scaling and general surface deterioration.
- b. Chemical finishing aids and evaporation retarders may be approved by the Project Manager.
- c. Should a voided surface occur during finishing and finishers experience difficulty in closing an open pavement surface, fresh mix or mortar should be obtained from in front of paving train and added to surface to facilitate finishing and produce a tight, closed pavement surface.

22. Tining (*SSHC Subsection 603.03*)

- a. The plans indicate those pavements that shall receive tining.

- b. Tining impressions are made in plastic concrete while grooves are made once concrete has hardened.
- c. The Department has changed tining requirements. Mainline pavement will now be longitudinally tined instead of transversely tined. Transverse tining shall be done with a rake, not a bull float. Ramps and other irregular areas that cannot be properly tined longitudinally shall be transverse tined.
- d. Mainline pavement tined surface longitudinally is the primary goal to reduce noise levels.
- e. Proper tining is critical. Longitudinal or transverse tining of the surface too early may result in grooves filling up with mortar or surface tearing. Tining too late results in a reduced groove depth.
- f. To obtain a uniform transversely grooved pavement inspector should check the following items:
 - (i) Texture machine operating properly and all control devices functioning correctly.
 - (ii) Pad line maintained in smooth and stable condition.
 - (iii) Tining rake carrier rails set to pavement crown, so uniform down pressure on tines maintained as comb sweeps down across the slab.
 - (iv) Four springs attached to carrier frame and to broom channel with a tension adjusting chain are identical and adjusted to obtain proper groove depth.
 - (v) Tines of comb parallel. A bent tine, which narrows spacing at tips, undercuts adjoining groove.
 - (vi) No build up of dry mortar near tips of tines. A build up of mortar widens groove at surface and may cause tearing or displacement of larger aggregate particles.
 - (vii) Steel tines not worn and comb in good condition, to ensure sufficient groove depth.
- g. Should an unsatisfactory tined surface result for any reason, stop the paving operation and do not allow resumption until the problem is corrected.
- h. Tine Determination
 - (i) Depth of the grooves may be determined by using a standard commercial tire tread depth gauge, but normally a visual inspection without measurements is adequate.

- i. Guidelines for Tining Concrete Pavement
 - (i) Tine mainline pavement longitudinally.
 - (ii) Ramps and small irregular areas can be transverse tined with a tining rake.
 - (iii) Tine all concrete pavements where posted speed limit will be 40 mph or greater. When a mainline is tined, include tining in intersections, acceleration lanes, deceleration lanes, left-turn lanes and ramps.
 - (iv) Do not tine concrete shoulders.
 - (v) On pavement built without curb, stop tining 6 inches (150 mm) from edge of pavement (for edge of pavement painted line.)
 - (vi) On pavement built with curb, stop tining 2 feet (600 mm) from back of curb.

- 23. Pavement Depression
 - a. A pavement depression prevents proper drainage of slab during periods of rain and may cause maintenance problems during the winter. This may be due to one or more of the following reasons:
 - (i) Screed not set correctly
 - (ii) Poor workmanship by finishers in manipulating straightedge
 - (iii) Improper tension between ends of trailing forms
 - (iv) Improper adjustment of edges attached to trailing forms
 - b. Check this deficiency by placing a 10 ft (3 m) straightedge or 4 ft (1.2 m) carpenter's level transversely on pavement surface and noting trueness of surface with bottom of straightedge.

- 24. Protection and Curing
 - a. The slab inspector in charge of curing should study the requirements for the method proposed for use by the contractor. If the method of cure involves the use of "blanket-type" coverings, these should be inspected and sampled, if necessary, prior to pavement production. Impervious coating material proposed for use must be tested before use. Although its application rate will not be less than 1.5 gal/22 yd² (0.3 L/m²) for tined surfaces and 1.0 gal/22 yd² (0.2 L/m²) for all other finishes, the rate of application may be increased depending on the moisture retention qualities of the impervious coating.
 - b. White pigmented curing compound that is approved for use is shown on the [Approved Products List](#). The Materials and Research Division should be advised as to the quantity and lot numbers involved. Reports will then be issued to the project. Curing compound not from tested stock must be sampled and tested prior to being used. We do not accept curing compounds by certificate of compliance or Project Manager's certification.
 - c. One method of curing is the use of "wet burlap and impervious coatings". When this method is used, the initial curing with wet burlap is very important as it prevents evaporation of the mixing water at the time when

hydration is most rapid. The wet burlap should be applied as soon as the fingertips can be gently touched to the concrete without becoming sticky. If hair checking develops during hot weather, the wet burlap should be applied immediately behind the finishing operations. Hair checks are much more objectionable than burlap marks. If the burlap is applied with care, and with the seams up, burlap marks will be held to a minimum. Water for curing takes priority over all other pavement operations. Impervious coatings are then applied after the first 20 hours of initial curing. The testing laboratory will test each lot of impervious materials received and will designate the quantity per square yard to be applied. A daily record of the gallons (liters) used and the amount applied per square yard (meter) shall be kept in the slab inspector's notebook. It will be the inspector's duty to see that the coating materials are applied uniformly and in an amount at least equal to the amount designated by the laboratory. The vertical edges of the slab shall be coated with the same quantity per square yard (meter) as the surface. Keep the material from coating any joint areas to which joint-sealing filler is to be applied.

(i) When curing with burlap, at times keeping the burlap in place and continuously in a dampened condition is an endless task. However, since proper curing is essential to good quality in the concrete, the curing requirements for the particular work should be reviewed and discussed with the contractor. It is the responsibility of the Project Manager to ensure that the contractor carries out the curing requirements as specified.

d. When hot dry and windy conditions prevail, the application or placement of curing material becomes extremely important.

25. Prevention of Rain Damage to Plastic Concrete

a. SSHC Sections 603 and 1002 require contractors to produce a quality product and have materials for proper protection of edges and surface of concrete available near work site. Contractor must protect pavement from damage due to rain. Failure to properly protect concrete may constitute cause for removal and replacement of defective pavement. At the preconstruction conference, it is important to emphasize that protective coverings and temporary forms must be available and that protection of fresh pavement from rain damage is the contractor's responsibility. The contractor should be advised to follow the weather forecasts closely to prevent being caught unprepared in case of rain. Plastic film is preferred for surface and edge protection, since burlap alone in a heavy rain is insufficient to prevent access of water and subsequent pavement surface erosion.

(i) Prior to start of paving operations the inspector should be assured that the contractor has sufficient material on hand, such as burlap, polyethylene sheeting or other approved material, to properly protect the pavement surface in case of rain. Sudden showers which might occur during paving operations or immediately after finishing operations require the exposed surface of the fresh concrete to be covered to prevent washing cement from the surface. Mixing and placing of concrete should cease immediately in the event of rain.

- b. The District Engineer and the Construction Division should be notified when pavements are damaged by rain so an evaluation of the damage can be made. Acceptance or rejection of damaged portions of pavement will be based on the extent of damage incurred as determined by the Project Manager. Repair of damaged edges and surface may be considered, but extensively damaged pavement may require removal and replacement.
26. Joints (*SSHC Subsection 603.03*)
- a. Joints are sawed in PCC pavements to eliminate random cracking and to provide areas for pavement to expand and contract. These control joints are then cleaned and sealed with various types of sealants to keep out water and incompressibles such as soil, sand, and gravel.
 - b. Transverse Construction Joints - The header board used to form the construction joint at the end of the day's run should be cut from 2 inch (50 mm) material and approximately 1 ½ inch (37.5 mm) shorter than the width of the pavement. Holes bored in the board to receive the load transfer dowels should be at least 1/4 inch (6 mm) larger in diameter than the dowel bars.
 - (i) When due to breakdowns, construction joints are necessary during the day, and work is resumed after a short delay, great care must be used in removing the header board from the green concrete. Any pressure or lift on the dowel bars will break the bond with concrete and cause the joint to spall at some future date.
 - (ii) Generally, header boards should be set 1/8 inch (3 mm) below normal crown at centerline. Observe the straightedging of the header joint the next morning and adjust the setting of the next header board, accordingly. When paving down steep grades (4 to 6 percent), set the header board 1/4 inch (6 mm) below crown elevation. When paving up steep grades, set the board exactly to crown elevation. Boards should be set at right angles to the pavement grade with dowel bars parallel to the subgrade.
 - (iii) Concrete pavement failures on the "morning" side of transverse construction joints have sometimes been noted. This is normally caused by unconsolidated concrete. Machine vibration should be observed at this point and if not considered adequate, hand vibrations for a few feet out from the header should be required.
 - (iv) Dowel bars on all joints shall be greased as shown in the plans.
 - c. Transverse Expansion Joints - The joint materials should be set at right angles to the pavement grade with dowel bars parallel to the subgrade and to the centerline of the pavement. Tilted or skewed dowels will "blow up" the joint at some future date when the pavement expands. The joint material must touch the subgrade throughout its entire length and there should be no gaps between the mastic sections. Concrete plugs form in such gaps and defeat the purpose of the joint. Make certain that the expansion tubes are not driven on past the stop lugs or the joint will fail to function. The 1 inch (25 mm) temporary filler between the ends of the

expansion material and the side form should be removed before placing the hot-poured joint material. If the temporary filler is composed of unyielding material, it should be removed the day after the pavement is poured to prevent spalling the corners of the concrete slab when the pavement expands.

- (i) The strike bar on the spreader and the screeds of the finishing machine should be raised slightly when making their trip over the joint. Machines pushing a heavy roll of concrete tend to tilt the mastic, and shovelers should be employed to transfer such rolls across the joint. The inspector shall check all joints for position behind the finishing machine by inserting a thin wood stake about 30 inches (0.8 m) long in the concrete alongside and in contact with the joint material. If the stake contacts the joint material all the way to the subgrade and appears to be plumb, the joint will function properly. Tilted joints should be dug out and reset.
- d. Contraction Joints - The specifications provide that plane of weakness joints shall be sawed. Great care and attention should be given to the planning of sawing joints. Sawing at the wrong time or sawing alongside of a crack already formed can be the cause of extensive maintenance work. The cutting of transverse-control joints to relieve early shrinkage stresses may be necessary depending on the type of slab, the atmosphere conditions and the amount of shrinkage inherent in the concrete. No exact time can be given as to when sawing of transverse-control joints should start, and it will be necessary to prepare a sawing sequence for each project.
- (i) The plans should be carefully checked to determine the location and depth of sawing required. Usually the specified depth of cut is different for transverse and longitudinal joints. The depth of cut should be checked as soon as possible so that the contractor may seal the joints.
 - (ii) On Reinforced Concrete Pavement, with transverse contraction joints at 46.5 ft (14.17 m), it probably won't be necessary to cut control joints except in very hot weather periods. It is recommended that on the first day of concrete paving, sawing of the transverse joints begin as soon as possible without excessive raveling or tearing. The time at which this sawing should start may vary from 6 hours on warm days to 20 hours in cold, cloudy weather. Sawing of these joints should continue progressively at the plan spacing until concrete is encountered that is so green that it cannot be sawed without tearing. Some slight raveling of the concrete must be expected. If a sharp edge joint is being obtained, it is quite likely that the concrete may have hardened sufficiently to result in uncontrolled cracking. This would indicate that sawing should be earlier or control joints should be made.
 - (iii) The first joint following the previous day's construction joint should always be sawed as a control joint. The older concrete will place sufficient stress on the newly placed concrete to produce an uncontrolled crack near the header if a plane of weakness is not provided at this point.

- (iv) *SSHC Subsection 603.03*, Paragraph 7 should be thoroughly reviewed and understood by both the inspector and contractor. Transverse joints near cracks developing before sawing should be skipped, the crack routed and filled with joint material. Sawing shall be discontinued when a crack develops ahead of the saw. If a joint is sawed where a crack exists or develops during sawing, the sawed joint or portion considered to not be the working joint shall be cleaned and epoxied.
 - (v) In the multilane pavement, for the companion lanes, those joints that are open and working should be sawed as control joints. Volume change stresses from the initial lane are transmitted through the tie bars and edge friction to the second lane. A matching plane of weakness must be sawed in the second lane to prevent formation of an uncontrolled crack.
 - (vi) Uncontrolled cracks in the initial lane must be matched with a control joint in the companion lane. In laying out joints, blocks of concrete should always be 10 feet (3 m) or more in length.
 - (vii) Instances have been noted where the depth of the sawed joint through the curb section was insufficient on concrete pavement construction requiring integral curb. The depth through the curb section is variable and is to be sawed as shown on the plans. This should be brought to the attention of the contractor and your assigned inspector.
- e. Longitudinal Joints - The time for sawing the longitudinal center joint is not critical. The concrete shall have hardened sufficiently to permit the sawing of a sharp-edged, clean cut joint.
- f. Sealing Joints
- (i) Sealing should not occur until the concrete has met strength to allow the Contractor on the slab. Ensure that sealant manufacturer's procedures are followed. Check for moisture, contaminants, and incompressibles in the joint before the sealant is applied.
 - (ii) Hot Poured Sealants
 - (1) Joints required to be sealed shall be filled immediately after they have been cleaned and dried, and checked for proper depth. A hot poured joint sealer must be applied with the use of a pressure-type applicator equipped with a nozzle which will fit into the sawed groove.
 - (2) The sealant material must be installed in a manner to allow the sealant to flow to the bottom of the saw cut and down into the underlying crack without causing settlement of the sealant at the surface of the joint. Placement of joint sealer should be done in a neat, workmanlike manner striving to eliminate any smearing of sealer on the pavement.
 - (3) The Project Manager should obtain the manufacturers recommendations for temperature control of the joint

sealer, and frequent measurements of the actual temperatures should be made to insure compliance with those recommendations.

- (4) If curing compound is applied on a slab with open joints the contractor should lay a rope or belt along the length of the joint to exclude the cure from the opening. If curing compound has been permitted to enter a joint, the contractor should be required to re-saw the joint.
 - (5) All joints to be sealed shall be cleaned with a jet of compressed air, flushed out with water under high pressure and diked before pouring the joint sealing filler.
 - (6) We have experienced some problems in the past regarding hot pour joint sealer and white pigmented curing compound. The problem stems from the fact that the manufacturer is supplying their distributor, or the contractor, with a certificate of compliance stating that the material meets Nebraska Department of Roads' specifications as well as the applicable ASTM and AASHTO specifications. In one instance, the certification also stated the material was pre-tested. However, this has since been corrected by the manufacturer.
 - (7) We want to emphasize that if hot pour joint sealer is from tested and approved stock, this material can then be used upon delivery to the project. The lot number will appear on the NDOT [Approved Products List](#) for approved stock. The Materials and Research Division should be notified as to the lot numbers and quantity delivered. If the lot number is not on the NDOT [Approved Products List](#), then the joint sealer must be tested and approved before it is used. We do not accept joint sealer by certificate of compliance or by a Project Manager's certification, unless this is the rubber modified asphalt compound consisting of an asphalt cement containing a minimum of 22 percent of new or reclaimed, synthetic or natural rubber. This material is accepted by a certificate of compliance furnished by the supplier per the Special Provisions.
 - (8) The foregoing instructions concerning tested and approved stock also applies to cold poured joint sealer, preformed joint filler, and pressure relief joint filler.
- (iii) *Preformed Polychloroprene Elastomeric Type (SSHC Section 1016)*
- (1) The construction procedures in *SSHC Subsection 603.03, Paragraph 7* are quite detailed and close adherence to these instructions is important to insure the proper performance of the seals. Important points to emphasize in this type of construction follow:

- Installation should result in less than 5 percent elongation of the performed seal.
 - Sawed joint dimensions should be of correct size - neither too large nor too small.
 - Sawed joints should be inspected closely for cleanliness at the time of installation.
 - Spalls should be repaired as indicated in the specifications.
 - Certification as indicated in Specification Subsection 1016 should be in the Project Manager's files before installation.
 - Excessive adhesive has been known to accumulate on the top of the seal, preventing proper expansion of the seal.
 - Hot dry weather can produce a condition of premature set to the adhesive and this can be the cause of seal popping.
 - The seals be placed at the specified depth. If placed too high, attrition will take its toll.
- (iv) Silicone Sealants (*SSHC Section 1014*)
- (1) For construction of the contraction joints, using only a saw cut (no well) silicone sealants are not allowed. Silicone sealants may be used by contract if a contraction joint with a well is allowed. However, they have fallen out of favor and currently not included in the NDOT Approved Products List. Silicone sealants would need to be added by permission. Silicone sealants shall meet requirements in SSHC Section 1014 and shall be installed in accordance with the manufacturer's recommended procedures.
- (v) Mastic Sealants
- (1) Mastic sealants are considered as temporary sealants and their composition is not tested. The contractor must submit a letter from the manufacturer certifying materials comply with AASHTO M 213 requirements for non-extruding and resilient bituminous, filter type, preformed joint filler or AASHTO M 33 for bituminous type (asphalt type) preformed joint filler.
- g. Cleaning Joints
- (i) The Project Manager must ensure adequate inspection of joint cleaning operations prior to sealing. *SSHC Subsection 603.03* discusses the required method of cleaning joints.
- (ii) In order for the joint sealant materials to adhere properly to joint edge, joint edges need to be properly cleaned. All re-cemented sawing residue from the initial saw cut operation must be removed

immediately after cut is made. If these joint faces are not properly cleaned, sealer will prematurely fail. This will start deterioration of pavement and will eventually result in spalled or faulted pavement due to water intrusion into joint.

- (iii) The sandblast wand should have a means to positively guide the nozzle along actual joint line. This is to insure that sandblast passage does not miss any of the joint face. This can be seen when sandblast nozzle passage shows as a wavy line on the pavement surface.
- (iv) Air compressors shall have suitable traps to remove moisture and oil.
- h. Sealing Sawed Joints
 - (i) The plans identify the joint sealant material to be used. All joints are to be sealed before any traffic is permitted on the pavement. If the Contractor elects to not seal the joints prior to their equipment operation on the pavement, special attention must be made to ensure incompressibles are removed.
- i. Joint Filling (*SSHC Subsection 603.03*)
 - (i) Hot poured asphaltic or any flowable joint material may flow out of the joint leaving an opening below the pavement surface which allows entrance of incompressibles into the joint opening. This will cause spalling of joint edges when pavement expands. To ensure a properly filled joint across the entire pavement width, it is good practice for the contractor to close the joint opening at pavement edge. This helps to prevent sealant from flowing out of the joint opening.
 - (ii) All joint sealant materials should be placed so that the top edge from 1/4 inch (6 mm) to 5/8 inch below pavement's surface. See paving details or manufacturer's instructions for exact elevation. Excessive filling of transverse and longitudinal joints can result in excessive sealant material being forced out of the joint and soiling the pavement surface. Excess sealant material should be removed from pavement surface prior to project acceptance.
- j. Sealing Equipment
 - (i) Hot poured asphaltic joint material may be overheated in hot pour kettles. An overheated sealant has lost its elasticity and will prematurely fail. Thermometers on hot pour kettles need to be checked and replaced if necessary. Calibrated thermometers are available from Quality Assurance Manager to use in checking contractor's thermometers.
- k. Backer Rod
 - (i) Backer rod is currently not being use with our current contraction joint design.
- l. Doweled Support Assemblies (*SSHC Subsection 603.03*)

- (i) To ensure that a doweled contraction joint will function as designed, it is critical that assembly be properly installed. Dowel bars provide load transfer across the joint without prohibiting the opening and closing of the joint during pavement temperature changes.
- (ii) Dowel Tolerances
 - (1) To permit pavement slabs to move longitudinally on the subgrade during expansion and contraction, dowels must be parallel to both centerline and surface of pavement. The plans show the dowel placement tolerances. Dowel assemblies should not be permitted to remain in place if wire supports cannot hold dowels in correct alignment. Position of outside dowel bar to edge of pavement slab shall be within plus or minus 1 inch (25 mm). The dowel bars shall be placed with a tolerance of 1/4" in both horizontal and vertical planes.
- (iii) Dowel Assembly Placement
 - (1) When placing assemblies on subgrade, contractors use bottom support wires of assembly as a guide for bar alignment. This is not objectionable provided bars are fabricated at proper angle to wire supports. Assemblies should be inspected for proper fabrication when delivered to project.
 - (2) Contractors shall not be permitted to block up or support the assemblies on bricks to obtain proper height of dowel bars. When paving project has two different slab thicknesses requiring load transfer devices, the contractor shall furnish correct height basket dowel assemblies specifically fabricated to position bars at mid-depth in slab for each slab thickness.
 - (3) Check for movement of assemblies during passage of slipform paver. If properly set, the side forms of the paver should not come in contact with the ends of wire bar supports. Check to ensure vibrators on paver or finishing equipment are set to proper height so vibrators do not touch steel during passage over assemblies.
 - (4) Workers who position steel and vibrate concrete must not step on joint assemblies. Assemblies must be firmly anchored to subgrade or subbase with a minimum of eight stakes per 12 feet (3.6 m) width to resist horizontal and vertical movement during concrete placement and subsequent finishing operations.

m. Marking Joint Locations

- (i) Prior to paving, dowel midpoint must be marked on the subgrade or granular foundation course so an accurate saw cut location can be made on cured pavement. A narrow band of paint can be applied to the subgrade at midpoint of dowels in same direction as proposed saw cut. This band of paint must be kept as narrow as possible to minimize chance of error in correctly locating saw cut. An alternate method would be to place a dowel basket staking pin on either side of pad line.
- (ii) Dowel midpoint markings should then be transferred to PCC concrete surface. This may be accomplished with a string line marking plastic concrete or by use of a chalk line after concrete has hardened. This should insure that the transverse joint will be sawn over the center of the dowel bar basket assembly. Do not permit the saw operator to eyeball joint sawing from one edge of the slab to the other.

n. Longitudinal Joint Design

- (i) The standard plans show joint layout details. The joint layout designs for paving plans have specific requirements for certain type joints which consider traffic movements during and after construction and the effect of the joint type on these traffic movements.
- (ii) Joints should be constructed as shown in the plans, unless the Standard Road Plans allow for alternates. Any requests by the contractor for joint substitution shall be submitted to the Construction Division for review.

o. Curing of Keyed and Doweled Joints

- (i) The vertical sides of pavement in areas where joints are constructed, must be cured with the use of a liquid curing compound is an acceptable method of curing this portion of the slab.
- (ii) Generally, little or no bond is obtained or expected between vertical faces of adjacent concrete. Deformation on tie bars provide adequate lateral support.

27. Integral Curb Placement

- a. Integral curb may be placed simultaneously with the pavement placement, directly behind the pavement finishing operation, or at some later date. When placed directly behind the finishing operation, the specifications require placement within 30 minutes from the time of placement of the pavement and that the curb be placed on a roughened surface. Both of these requirements are important to insure an adequate bond to the slab. If the integral curb is to be placed at a later date, reinforcing steel, as indicated in the plans, shall be placed during the construction of the slab.
- b. Two important items to note during the inspection of constructing curb is proper consolidation of the concrete and configuration of the finished

curb. Proper consolidation will eliminate voids on the backside. Should voids be present they are to be filled with a mortar, immediately if slip-form methods are being used or in the case of forms immediately upon removal of the forms. Configuration should be checked for conformance with dimensions shown in the plans. If hand methods are being used a "mule" type float of the proper configuration should be used in the construction of the curb.

28. Pavement Station Stamping

- a. Station location of all PCC pavement shall be stamped in plastic concrete at every station (100 ft/100 m) by the NDOT inspector.
- b. Permanent Station Numbers - Each station number shall be marked permanently in the surface of the concrete slab by the use of metal dies furnished by the department. The numbers should be stamped neatly in the concrete just before it takes its initial set. They should be placed about 6 inches (150 mm) in from the right-hand edge of the slab so that they can be read from the right roadway shoulder.
 - (i) On interstate concrete pavement, station numbers should be stamped on the outside edge of both roadways (sides: away from the median). These numbers will also be 6 inches (150 mm) in from the slab edge and facing so that they can be read from the outside asphalt shoulder. Placement of station numbers on all ramps, loops, "S" roads, etc., should be made in conformity with the first paragraph of this section.
 - (ii) On concrete slabs having integral curbs, the location of station numbers will vary between projects according to desires of parties most likely to use them in the future. The city engineer and/or District Engineer should be consulted on this matter prior to construction.

29. Repair of Deficient Pavement

- a. Pavements damaged by rain and deficiencies caused by poor workmanship may be repaired or restored to an acceptable condition without complete removal and replacement of damaged areas.
- b. Rain damage varies considerably depending on rainfall intensity, duration, and protective measures taken by contractor. Covering and side forms placed by the contractor afford sufficient protection to unhardened concrete in some cases. In other cases, surface and edges may erode to such a degree that removal and replacement of slab is the only solution.
- c. Guidelines follow for corrective measures that may be taken or used to restore damaged pavement to an acceptable condition. This instruction is not intended to cover the whole spectrum of correcting deficiencies that may occur on a paving project during construction. Other proposed procedures or methods suggested by the contractor may be considered.

d. Recommended Repair Method (*SSHC Subsection 108.05*)

(i) Rain Damage and Excessive Edge Slump

(1) On plastic concrete:

- Pavement surfaces which have slight surface damage due to placement of protective covering or sandy appearance may be retextured provided concrete is still plastic and in workable condition.
- Pavement surface which has texture removed and coarse aggregate exposed may be reworked by adding fresh concrete (same mix as pavement) to surface, rescreeding, texturing, and curing. Areas reworked must also meet specified smoothness requirements.
- Eroded edges may be repaired by setting side forms and replacing eroded concrete with fresh mix.
- Excessive edge slump may be corrected by setting side forms of proper height along slumped edge and refinishing to the correct elevation.

(2) After concrete has cured and hardened:

- Pavement surfaces that have lost transverse groove texture without affecting surface profile shall have transverse or longitudinal grooves reestablished.
- Pavement surfaces which have been severely eroded require reprofiling by diamond grinding equipment and subsequent reestablishment of transverse grooving.
- Minor edge erosion and edge slump with a key and doweled joint and adjacent slab need to be butted to existing pavement. Establish a new edge, not to exceed 3 inch (75 mm) in from previous edge, by sawing to the top of the tie bar, remove concrete and replace when new adjacent pavement is poured. If necessary to go more than 3 inch (75 mm) from edge of pavement to correct eroded or slumped edge, the edge shall be repaired by using pavement patching methods prior to pouring adjacent slab.
- Excessive edge slump may be repaired by using pavement patching methods.
- Edges or panels that have been severely eroded may require all or a section of lane to be removed or replaced. If determined that a section of lane more than 2 ft (600 mm) in width should be

removed, then entire lane or panel shall be removed and replaced with new concrete. Areas less than 2 ft (600 mm) in width shall require full depth repair with holes drilled and tie bars installed to anchor new concrete to remaining concrete.

- For areas with extreme severely eroded surface and edges, contractor should be required to place a bonded PCC overlay.

(ii) Vehicle Traffic on Plastic Concrete

- Remove and replace sections where rutting is severe.
- Minor wheel track rutting may be repaired by using pavement patching methods.

(iii) Shrinkage Cracks

- Remove and replace affected areas with new pavement in severe cases.
- Minor cracks may be filled with pressure injected epoxy or repaired using pavement patching methods.

(iv) Rough Pavement Sections

- Surface variations which exceed specification smoothness requirements require correction by the contractor. Surface correction shall be accomplished with approved diamond grinding equipment. Use of milling machines, Roto Mill, Galion Scarifier, or other impact devices shall not be permitted. Reestablishing transverse grooving of corrected areas is not required but longitudinal grooves must be established. Equipment for regrooving shall be specifically designed for grooving concrete with a cutting head fitted with diamond blades. Use of hand held equipment is not permitted.

(v) Limitations

- (1) Necessary corrective measures on hardened concrete shall only be made after concrete attains age and strength requirements in *SSHC Section 603*.
- (2) All required corrective measures shall be completed prior to coring for pavement thickness measurements.
- (3) Approval of the Construction Division is required before placing a bonded PCC overlay.

30 Mud Ball Repair

- a. Occasionally mud balls appear in the surface on new concrete pavements. These usually are due to clay balls from a quarry or mud thrown into dump trucks from portable batch plant located at a wet site.
- b. Correction of any discovered mud balls in pavement surface shall be as follows:

- Any thin concrete skin around perimeter of mud ball should be removed so that nearly vertical void walls remain.
 - Each void shall be cleaned by a high pressure washer, followed by air blasting to dry void.
 - Voids shall be filled with an approved grout. This material shall be used according to manufacturer's recommendations.
 - Surface of filled voids shall be given the same texture as surrounding pavement.
 - Void shall be given proper cure time recommended by manufacturer prior to opening roadway to normal traffic.
- c. If a severe problem with mud balls is suspected and the suspicions have been document, then formal acceptance by Project Manager should be delayed until the following spring. This will allow the winter freeze-thaw cycles and snowplowing activities to expose additional mud balls located adjacent to pavement surface. These newly discovered mud ball areas will then also require corrective measures as stated above. The Project Manager may also elect to have the contractor use a high pressure sprayer (1200 psi) to locate mud balls and allow the project to be finalized immediately after any repairs are made.
31. Cold Weather Paving and Plant Operations
- a. Cold Weather Pavement Protection
- (i) During cold weather, *SSHC Subsections 601.01, 603.03 and 1002.02* requires that newly placed paving be protected against freezing temperatures. This protection is necessary to allow the hydration process of the curing concrete to continue in cold weather. Adequate protection of concrete allows for paving to be placed later in the cold seasons.
 - (ii) Materials that may produce acceptable insulation include:
 - 3 layers of Burlap.
 - 1 layer of Fast Track Blankets.
 - 1 layer of 1/2 inch (12 mm) extruded polystyrene, must be weighted down.
 - 2 layers of 1/4 inch (6 mm) air celled polyethylene.
 - 1 layer of 1/2 inch (12 mm) air celled polyethylene.
 - (iii) Do not advise contractor regarding cold weather protection.
 - (iv) When cold weather protection is required, the contractor will not be reimbursed for whatever protection is used.
- b. Cold Weather Plant Operation
- (i) *SSHC Subsection 603.03* states that concrete mixing and placement may be started when air temperature is at least 40° F (5°C) and rising. In the late fall season before the subgrade begins to freeze and soil temperatures are still relatively warm, it is

permissible to allow paving plant operations to begin below 40° F (5°C) providing a warming weather forecast is predicted. Paving plant operations basically self-regulate during these conditions.

- (ii) The intent is to maximize the remaining good paving weather still available in the fall. This provision is not intended to make a paving day out of one that is not but to allow for as much concrete pavement placement as possible during good weather.
- (iii) After the subgrade begins to freeze, the above provisions should be halted and the Specifications strictly enforced.

603.04 METHOD OF MEASUREMENT

- 1. Requirements for Thickness
 - a. *SSHC Subsection 603.05* indicates the thickness requirements and includes a table of payments to be made for concrete of less than plan thickness. The table is based on the premise that a pay deduction should be proportioned to the reductions in service resulting from thin pavement. Thus the reductions in payment are quite severe.
- 2. Material Quantities
 - a. Concrete pavement is measured for payment in square yards (meters) in place and accepted, minus deductions. The reinforcing steel and dowel bars required by the Plans and Special Provisions will be considered subsidiary to the other pay items in concrete pavement construction.
 - b. *SSHC Subsection 603.04* states that the quantity of concrete pavement will be measured by the square yard (meter). This is interpreted by the Construction Division to mean that when the plans, stakes, etc., order a nominal width of pavement and the Project Manager determines that this nominal width requirement is met or exceeded, the nominal width will be used to compute the quantity for the concrete pavement item, i.e., the contractor should not be permitted to increase their compensation by purposely or inadvertently constructing the pavement to a width greater than the nominal width.
 - c. Base course, foundation course, and subgrade preparation are not measured quantities. They are established quantities that are based on the paved area.
- 3. Concrete Driveways
 - a. *SSHC Subsection 609.04* states that concrete driveways will be measured by the square yard (meter). This is interpreted by the Construction Division to mean that when the Project Survey Crew stakes the driveway for certain dimensions these are the dimensions that will be used to compute the area for payments.
- 4. Records and Reports
 - a. Daily Report of Concrete Pavement Laid (NDOT Form 85) should be prepared daily. The cylinder data for the day covered by the report should be written at the bottom of the form. Reports should be delivered to the plant inspector as early as possible so they may complete their records for the day reported.

- b. When reporting multilane pavement, or when paving one lane on 2-lane pavement always report the lane being paved. Identification of the lane on multilane pavement should be positive - such as: 12' lane, 12'-24' Rt. of centerline. Lack of this information may result in confusion and delay in preparing the pattern of cores for the core drill. Sketches of irregular areas should be shown on the reverse side of the slab report NDOT Form 85, or prints of intersections and other unusual layouts may be ordered from the Lincoln Office for the purpose of logging daily pour information and should be turned in with the slab report which substantially completes the area involved. Sketches need not be elaborate but should clearly identify the area placed with any necessary dimensions. A diary record is also required.
- c. Section corners falling within the area of the concrete pavement may be perpetuated by a registered land surveyor who will take a core as described in *CM Section 1300.03*, "Perpetuating Section Corner Markers". In many instances it may be possible to set the section corner while the concrete is plastic and cores need not be taken. If cores are needed to set the section corners, a list of the corners to be so perpetuated should be submitted to the Materials and Research Division as early as possible prior to the time that the pavement is to be cored. This list should include the station location and distance right or left of centerline of each section corner to be cored.

603.05	BASIS OF PAYMENT
604.00	CONCRETE BASE COURSE
604.01	DESCRIPTION
604.02	MATERIAL REQUIREMENTS
604.03	EQUIPMENT
604.04	CONSTRUCTION METHODS
604.05	METHOD OF MEASUREMENT
604.06	BASIS OF PAYMENT
605.00	CONCRETE PAVEMENT REPAIR
605.01	DESCRIPTION

- 1. Full Depth PCC Patches
 - a. The plans show the details for full depth patches for PCC pavement or resurfaced PCC pavement. Each of these details identify the required depth of concrete for the patch. There are six pages of details that describe pavement repairs that will not receive an overlay and four pages of details that describe pavement repairs that will receive an overlay. However, only those details that are applicable are included in any set of plans. In general, if the length of the repair is 4' to 9' (1.2 m to 2.7 m), then it is considered "Joint Repair." If the repair is over 9' (2.7 m), then it is called "Pavement (Panel) Repair."
 - b. The transverse and longitudinal faces of the pavement around the repair receive different treatments. The surface in the transverse (width of

pavement) direction will either receive dowel bars or have the surface beveled to wedge the patch so it will not settle below the existing roadway surface. The longitudinal surface will be vertical and may have tie bars (see plans for details).

- c. The details also show how to remove the pavement. The detail for beveling the transverse ledge includes both a full depth saw cut and a 2-inch + ¼ inch (50 mm + 6 mm) deep saw cut. The full depth saw cut is usually performed with a wheel saw. These saw cuts are intended to sever the pavement totally so the existing pavement can be completely removed. The breakout area between the full depth cut and the 2-inch (50 mm) depth cut should create a beveled ledge that will wedge the patch in place and prevent it from slipping below the roadway surface.

605.02 MATERIAL REQUIREMENTS

605.03 EQUIPMENT

605.04 CONSTRUCTION METHODS

1. Saw Cuts In Full Depth PCC Patches

- a. Some contractors have delayed saw cuts for joints in full depth PCC patches until after minimum 5-hour cure period (on two-lane roadways). Due to rapid setting concrete used for these patches, random cracks often appear when joints are not sawn quick enough. Any joints in full-depth patches shall be sawn as soon as possible as long as raveling of saw cut edges does not happen. This early sawing will require temporary removal and replacement of required insulation boards in cold weather.
- b. Any random cracks that appear due to a delay of the saw cut operation shall be repaired by the contractor. Repair will consist of routing random cracks with a crack saw and sealing with hot pour sealant. These repairs will be at the expense of the contractor.

605.05 METHOD OF MEASUREMENT

1. Low Strength Deductions

- a. Materials and Research will make the recommendations for the deductions for concrete pavement because they establish the strength --- from cores which they have taken --- used to determine the basis of payment. The District will apply the deductions to the contract.
- b. Payment for PR concrete, unlike pavement, is based upon cylinder strengths or maturity method rather than from core strengths. Accordingly, the Project Manager should make the calculations and deduction when PR concrete for patching does not make the required strength. The deduction should be based on the 24-hour break strength of a cylinder using the deduction factors shown in Table 603.03.
- c. If the contractor elects to open the repairs to traffic before they have acquired the required strength, the repairs are non-compliant. The field staff should contact the Construction Office for guidance on removal or acceptance at a reduced price.

605.06	BASIS OF PAYMENT
606.00	CONCRETE CURB AND CONCRETE GUTTER
606.01	DESCRIPTION
606.02	MATERIAL REQUIREMENTS
606.03	CONSTRUCTION METHODS
606.04	METHOD OF MEASUREMENT
606.05	BASIS OF PAYMENT
607.00	CONCRETE SIDEWALKS, BIKEWAYS, AND MEDIAN SURFACING
607.01	DESCRIPTION
607.02	MATERIAL REQUIREMENTS
607.03	CONSTRUCTION METHODS
	ADA REQUIREMENTS
607.04	METHOD OF MEASUREMENT
607.05	BASIS OF PAYMENT
608.00	CONCRETE ISLAND NOSE
608.01	DESCRIPTION
608.02	MATERIAL REQUIREMENTS
608.03	CONSTRUCTION METHODS
608.04	METHOD OF MEASUREMENT
608.05	BASIS OF PAYMENT
609.00	CONCRETE DRIVEWAYS
609.01	DESCRIPTION
609.02	MATERIAL REQUIREMENTS
609.03	CONSTRUCTION METHODS
609.04	METHOD OF MEASUREMENT
609.05	BASIS OF PAYMENT
610.00	CONCRETE MEDIAN BARRIERS
610.01	DESCRIPTION
610.02	MATERIAL REQUIREMENTS
610.03	CONSTRUCTION METHODS
610.04	METHOD OF MEASUREMENT
610.05	BASIS OF PAYMENT
611.00	SEALING TRANSVERSE AND LONGITUDINAL CRACKS
611.01	DESCRIPTION

611.02	MATERIAL REQUIREMENTS
611.03	CONSTRUCTION METHODS
611.04	METHOD OF MEASUREMENT
611.05	BASIS OF PAYMENT
612.00	SEALING TRANSVERSE AND LONGITUDINAL JOINTS
612.01	DESCRIPTION
612.02	MATERIAL REQUIREMENTS
612.03	CONSTRUCTION METHODS
612.04	METHOD OF MEASUREMENT
612.05	BASIS OF PAYMENT

DIVISION 700

BRIDGES, CULVERTS, AND RELATED CONSTRUCTION

**DIVISION 700
BRIDGES, CULVERTS, AND RELATED CONSTRUCTION**

701.00 GENERAL REQUIREMENTS

701.01 DESCRIPTION

701.02 GENERAL PROCEDURES

701.03 EQUIPMENT

702.00 EXCAVATION FOR STRUCTURES

702.01 DESCRIPTION

1. All excavation should be done as shown in the plans. .
2. Inspector should be present when an area is being backfilled. The inspector should check to see that the backfill materials are as specified. The materials shall be placed as prescribed in the *SSHC Subsection 205.03 or 702.03* as appropriate.
3. Structure excavation includes all excavation, removal of obstruction, bailing, draining, pumping, sheathing, construction and removal of cofferdams, backfilling, compacting and disposal of any excess material necessary to construct the structure in question.

702.02 MATERIAL REQUIREMENTS

1. Unsuitable Material Excavation (*SSHC Subsection 702.05*)
 - a. When unstable material is encountered it shall be removed and backfilled with approved material. The material shall be measured in cubic yds. (meters) before it is placed. Payment for the extra work material and all work involved will be paid for in accordance with *SSHC Subsection 104.02 para 5*. The inspector should make an inspection of all structure footings as they are being excavated by the contractor.
 - b. Pier footings should not be constructed on unsuitable material. It is true that if the footing is supported by piles, the rock placed at the bottom of the footing serves no structural purpose. The Contractor should provide for a solid base to hold the concrete in the forms. However, the contractor is not entitled to a rock surface on which to work at the Department's expense.

702.03 CONSTRUCTION METHODS

1. Culvert Excavation (*SSHC Subsection 702.03*)
 - a. All culverts should be constructed with a minimum of approximately 12 inches (300 mm) of cover exclusive of surfacing. An accepted method for obtaining specified bedding for these culverts is to require the contractor to furnish a template conforming to the dimensions of the culvert pipe. This template is then used for shaping the trench to the specified depth. (see Standard Plan 411)
 - b. Never allow any part of a pipe culvert to rest on rock or other unyielding materials. When rock is encountered in the bottom of the trench, it shall

be removed to a depth of at least 6 inches (150 mm) below the subgrade and back filled with suitable earth or sand.

- c. The Specifications provide that where unstable subgrades are encountered under pipes or pipe-arch culverts, the unsuitable material shall be removed and the excavated area refilled with gravel, crushed rock, or other suitable material. When crushed rock is used, care should be taken to place the fine rock immediately beneath all metal pipes to prevent abrasion of the galvanized coating. When gravel or crushed rock is used in place of unsuitable material, it will be measured in cubic meters before it is placed. If "Granular Backfill" is not included on the project, payment for furnishing, hauling and placing this material will be made per SSHC Subsection 104.02 para 5. (*SSHC Subsection 702.05*)
 - d. The backfill near a pipe or box culvert is more expensive than excavation in the surrounding area. Therefore, in the *SSHC Subsection 702.05 paragraph 7. b.*, limits are placed on the quantities "Excavation for Box Culvert" and "Excavation for Pipe, Pipe-Arch Culverts, and Headwalls."
2. General Structure Backfilling (*SSHC Subsection 702.03*)
- a. This operation may involve *SSHC Sections 205, 702, and Table 702.01*. The inspector should insure that all applicable sections are followed. The compaction of backfill material close to structures must be given special attention. Mechanical tampers should be operated carefully in such a manner as to obtain the required density without damaging the structure.
 - b. Before any material is placed, the area to be backfilled should be inspected for trash or perishable matter. The materials to be used for backfill should be given careful consideration. Only those that will produce a dense, well-compacted backfill should be used. Granular materials are desirable as much less effort is needed to compact them than clay.
 - c. When abutments are tied to an anchor or deadman by means of tie rods, care should be taken in the back filling operation. The backfill should be placed in layers, starting at the anchor or deadman and working toward the abutment. Hand tamping may be required around the tie rods, abutment and anchors.
 - d. Backfilling must not be started without the permission of the Project Manager and in the case of concrete structures not until test cylinders show a minimum strength of at least 70% of the design compressive strength.
 - e. Backfill should be brought up evenly to the elevation shown in the plans. Granular material must be placed in not more than 6 inches (200 mm) layers (lifts) and should have sufficient moisture to facilitate compaction. Do not allow dumping of granular material directly from the truck into the excavation if this will result in lifts/layers greater than 6 inches.
 - f. Special attention should be given to culvert wingwalls and flumes to insure proper compaction to prevent erosion and possible washout. The soil should be brought up even with these walls so the surface water will flow over these walls and not along them. Heavy equipment should be kept 3 feet (1 m) or more away from these wingwalls. Compaction within

3 ft (1 m) of the wingwall shall be with pneumatic hand tampers or small hand operated vibratory plate compactors.

- g. Backfill for Bridges - Moisture and density requirements for backfill which is to provide support for subsequent construction will be shown in the plans. Backfill which is not to support later construction shall be compacted to 95% of maximum density without definite moisture limits.
 - h. Backfill for Culverts - When backfilling pipe culverts, the lifts shall be deposited and compacted alternately on opposite sides of the pipe to avoid lateral displacement. The inspector should also watch for vertical displacement. This may occur when tamping adjacent to the lowest 90 degrees of the pipe and should be checked from the grade stakes as backfilling progresses. The pipe should be tied down if any uplift is noted.
 - i. Necessary precautions should be taken against washing under the pipe in case of rain. Compacted dikes or temporary earth headwalls at the inlet end will often save removing and relaying the pipe after a heavy rain. All drainage structures in the process of construction should be carefully inspected for washouts at the sides and beneath the structures after rains.
 - j. Flowable fill is sometimes included in the plans for backfilling culverts. The plans will identify the locations and show the details for using the flowable fill. *SSHC Section 1003* defines Flowable Fill requirements.
3. Concrete Seal Course (*SSHC Subsection 702.03*)
- a. When it is impossible to dewater the foundation bed or box culvert footing or if live springs develop within the area, a seal course should be constructed below the elevation of the bottom of the footing. Concrete for seals constructed underwater shall contain 10% excess cement and be placed in accordance with *SSHC Subsection 704.03*. The concrete shall be allowed to harden a minimum of 72 hours after completing the final pour before dewatering and continuing work on the structure. Seepage through inadequate or poorly constructed cofferdams shall not be justification for placing a seal course.
4. Foundations
- a. Staking and Checking Locations of Structures - - Check and Double Check
 - (i) All measurements and skew angles must be independently checked. From past practice, "independently checked" meant having a second survey party come in, setup, and completely resurvey (verify) original staking. If GPS and Level Rod are being used to determine structure locations and elevations, it is always good to check in at the beginning and end of the survey with known control points to verify your equipment is properly calibrated.
 - (ii) Stakes used should be substantial and protected from disturbance. Offset stakes for each pier and abutment must be placed outside the area of contemplated work. Be sure to use appropriate and consistent markings when conveying information

on stakes to the contractor. (Station, offset, from CL or edge of structure, etc.) Work with the contractor on the project to establish expectations, at the beginning of construction.

- (iii) Any checks suggested by the contractor should be considered, since the site superintendent usually has a good idea of the structure layout in relation to existing features such as trees, old structures, etc. Each stake must be clearly marked to denote its function. Pier numbers must correspond with plan designations.

b. Documentation

- (i) A staking diagram for each structure must be recorded in a permanent survey field book (data file). This sketch must show the exact location of each hub and the markings made on each guard stake. IT IS NOT COMPLETE UNLESS IT SHOWS THE MEASUREMENTS MADE AS CHECKS ON THE ACCURACY OF THE STAKING LAYOUT. Names of those in the staking party should be entered as well as the date, design and project numbers, location, type of structure, and any other pertinent information.

5. Common Survey Errors to Avoid

- a. Turning the wrong skew angle.
- b. Errors in measuring from piers to abutments (This should be detected by an overall check from abutment to abutment.)
- c. The centerline of the bridge is not always on centerline of the road (This is quite common on interstate bridges.) A bridge with a sidewalk may not be centered on its pier(s).
- d. False readings using GPS equipment. Be familiar with the current equipment that your office uses prior to staking out project features. Utilize the “independently checked” system until you are familiar with the equipment. Insure that your equipment is properly connected to satellites, base units, etc., depending on the control you are using.

6. Encountering Old Substructures (*SSHC Subsection 104.06*)

- a. *SSHC Section 203* describes the removal requirements when structures interfere with the new work. Existing substructures are usually shown on the plans. If the designer intended to miss some of these old substructures and the contractor later encounters them, payment will be made to the contractor by change order to remove that portion in conflict. Payment will not be made if plans indicate the new substructure would hit the old structure. See *SSHC Subsection 104.05* for a list of approved unforeseen obstructions.

7. Bridge Deck Removal

- a. Contractors generally can be expected to be able to remove the deck without damaging the girders. However, the contractor must use some caution. The contractor cannot use the same force directly over a girder as would be applied over the “free/open” space between girders.

- b. Sometimes a contractor will start the removal work properly with heavy blows only in the “free” space. However, either from impatience, changes to the equipment operator or for some other reason, we have seen the contractor at some point begin to apply too much force directly over the girders. This may damage the girders.
- c. Forewarn the contractor and monitor their operation to make sure girders are not damaged. This is covered in the contract but is still important to monitor in the field.

702.04 METHOD OF MEASUREMENT

702.05 BASIS OF PAYMENT

703.00 PILES AND PILE DRIVING (SSHC Section 703)

703.01 Description

- 1. SSHC References
 - a. Section 703 Piles and Pile Driving
 - b. Section 705 Precast/Prestressed Concrete Structural Units
 - c. Section 1002 Portland Cement Concrete
 - d. Section 1004 Portland Cement
 - e. Section 1025 Steel Wire for Prestressed Concrete Units
- 2. Inspection Crew
 - a. Project Manager (PM)
 - b. Construction Technician
- 3. Equipment
 - a. Saximeter
- 4. Material Procedures
 - a. Check that all piling is acceptable for driving.
 - b. Material certifications or reports should be given to Project Manager and evaluated before use. For steel pile, the heat numbers of the pile and their location in the structure should be recorded. The Pile Driving Application is a good location to record this information.
- 5. Steel Piling
 - a. Steel bearing and sheet piling must be stored on suitable skids [6 inch (150 mm)] ground clearance recommended) and should be kept clean. Don't allow weeds and foreign material in storage sites.
- 6. Pre-cast Piling
 - a. Piling must be adequately supported when stored and handled to prevent excess deflection. The surface finish of concrete piling that will be exposed at the completion of driving (bent piles in concrete slab bridges) shall not be damaged or discolored.

7. Cast-in-Place Concrete Piles Procedures
 - a. Check shells immediately before placing any concrete (shape and accumulation of water). Use a drop cord.
8. Pile Driving Procedures
 - a. The contractor should build a frame (sometimes called a checkerboard) to hold each pile in the exact position for driving. The contractor may also mark the exact location of each pile instead of using a frame.
 - b. Before driving any piles, the inspector should perform the following duties:
 - (i) Verify that piles will be driven exactly as shown in the plan pile layout.
 - (ii) Check pile spacing, and record heat numbers (steel pile), code identification (concrete pile) and other pertinent information. Document points and splices.
 - (iii) Verify cut-off elevations against a permanent reference.
 - c. Confirm that the Project Manager, inspector and contractor understand:
 - (i) How to check penetration depth at any point.
 - (ii) How to take and record bearing tests data with saximeter.
 - (iii) How to determine the cut-off elevation for individual piles.
 - d. SSHC Subsection 703.03, Paragraph 2. allows bearing piling to be driven with a gravity hammer for the first half of the penetration when bearing does not exceed one-third of the design bearing.
 - e. Concrete sheet piling shall be driven with a preapproved hammer.
 - f. Do not allow augured pilot holes or preliminary jetting to be greater than 30% of the below-ground pile length.
 - g. Gravity hammers used to drive piling to final cut-off elevation shall be preapproved. The fall of gravity hammers shall be regulated so as to avoid damage to the piles. Hammer fall shall not exceed 15 ft (5 m) for steel bearing piles, or 8 ft (2.4 m) for precast concrete piles and shells for cast-in-place piles.
 - h. Do not allow hammer fall to damage piles.
 - i. Leads are required on all driven piles. Leads shall be held in proper alignment.
 - j. Swinging leads are permitted with steam, air or diesel hammers.
 - k. Guyed, braced, or fixed leads are required with gravity hammers.
9. Bearing and Sheet Piles Procedures
 - a. Frequently check the pile for plumbness or for required batter. Do not allow a variation of more than 1/4 inch/ per foot (6 mm per 300 mm) of pile during driving.
 - b. Tops shall not be out of line more than 2 inches (50 mm).
 - c. Adjacent sheets shall be in line within a 0.4 inch (10 mm) tolerance.

- d. The inspector should observe the pile carefully while it is being driven. A sudden increase in the penetration may indicate a broken or collapsed pile.
 - e. Remove and replace all broken, split, or misplaced piles. If removal is impractical, contact the Construction Division for instructions on the procedure to be followed.
 - f. Lead with the tongue or ball end of sheet piles to keep the groove or socket clean.
 - g. The options when a pile is at cut-off elevation, and not at design bearing are:
 - (i) If less than 10% of the piles in any group fail to reach bearing, the average pile bearing may be adequate to support the structure.
 - (ii) Additional piling may be added to the group.
 - (iii) Extend the piling and drive to obtain design bearing.
 - (iv) Determine a soil set up factor and then drive to cut-off elevation.
 - (v) Use pile-driving analyzer to determine bearing.
 - (vi) Run a load test to check if bearing capacity is obtained.
 - h. Notify the Construction Division when two or three consecutive piling do not attain design bearing.
 - (i) Record pile data in the Pile Application.
 - (ii) E-mail a copy of the “.pil” file and a PDF to Materials & Research and to Construction Division.
 - (iii) Do not use contractor provided charts to determine bearing.
10. Soil Setup Factor
- a. Two representative piles shall be driven to 2 ft (600 mm) above cut-off elevation (see SSHC 703.03). One pile will be used to warm the hammer and the other will be used to determine the setup factor. Always use the pile with the lowest bearing capacity to determine the soil setup factor.
 - b. The piling at cut-off plus 2 ft (600 mm), will be rested for 36 hours and then driven to cut-off elevation with a "warm" hammer.
 - c. The Project Manager will record the penetration for each ten blows of the hammer until cut-off is reached. When doing a setup test, it is very important that the first 10 blows are recorded.
 - d. Record data and call it in to the Geotechnical Section.
 - e. The factor and a decision on what action to take will be sent back to the Project Manager.
 - f. Geotechnical Section recommendations shall be recorded under the Remarks Section of the pile driving record.

11. Bearing Capacity Procedure
 - a. Determine bearing at or just prior to the pile reaching final penetration. Always use the last 10 blows to determine the final bearing capacity.
 - b. When determining bearing, the inspector shall be certain that all of the following conditions exist:
 - (i) For single action, the hammer shall have a free fall.
 - (ii) The head of the pile shall be free from crushed or broomed fibers.
 - (iii) The penetration of the pile shall be at a reasonably quick and uniform rate.
 - (iv) There is not excessive bounce of the hammer. Deduct twice the height of the bounce from "H" pile for gravity or stream hammers. No deduction is made for diesel hammers.
 - (v) If the driving is stopped for more than 2 hours, the pile shall be driven at least 1 ft (300 mm) before the bearing capacity is determined.
 - (vi) For battered piles driven with gravity hammers, see *SSHC Subsection 703.03*, Paragraph 4 for bearing determination.
 - c. The energy values for common diesel hammers presently in use are listed in *SSHC Subsection 703.03*, Paragraph 4. If the contractor intends to use a hammer not listed, the Geotechnical Section should be contacted to obtain the appropriate energy value.
 - d. For bearing capacity computations the mass of the driving cap may be taken from the manufacturer's freight bill or measured. The mass of the pile shall be determined as follows:
 - (i) Steel "H": Mass per foot (meter) times length at time bearing is determined.
 - (ii) Concrete: Volume times 150 lb/ft³ (2400 kg/m³).
12. Reference Points
 - a. The reference point should be an object with a fixed elevation or horizontal distance from the pile. Mark the point where the reference intersects the pile. After the required number of blows, mark another line at reference intersection and the distance between the two lines is penetration. Average penetrations can be computed from several measurements.
13. Pile Driving Analyzer (PDA) Procedures
 - a. Contact the Geotechnical Section to schedule personnel and equipment. If test piles are shown on the plans, PDA testing is required.
14. Static Pile Load Test Procedures
 - a. The Department will furnish the equipment and personnel for conducting the test. The contractor shall unload, erect, dismantle and reload the testing equipment. Payment for this work shall be by the each for each test.

- b. If a temporary anchor pile is required. It will be paid for as extra work.

15. Method of Measurement Procedures

- a. If required bearing is obtained at minimum penetration and this is shorter than the order length, the contractor should be encouraged to continue driving until the order length has been driven. Usually they will want to drive this extra length to avoid payment deduction. Discontinue driving beyond minimum penetration when:
 - (i) Practical refusal is reached.
 - (ii) Further driving may result in damage to the pile.
- b. If practical refusal is reached before minimum penetration, discontinue driving and notify the Geotechnical Section and do not cut off the pile without their approval.
- c. No payment will be made for pile length driven beyond the order length without PM approval.
- d. When steel "H" pile and steel pipe pile are driven to the exact cut-off elevation without crimping or damage to the top of the pile, they do not need to be cut off. Length of pile cut-off (measured as provided in SSHC Subsection 703.05) shall be paid at 60% of the piles unit price.
- e. It will be necessary to pay for pile cut-off only under the following conditions:
 - (i) When practical refusal is reached before minimum penetration and the pile cannot be driven or jetted further.
 - (ii) The contractor elects to stop driving after reaching bearing and minimum penetration but before the order length is driven.

16. Mass For Prestressed Concrete Bearing Pile

For computing bearing capacity required on the Pile Application.

Pile Type	Constant Section	
	Mass Per Meter of Pile Kg/m	Weight Per Foot of Pile Lb/ft
I	220	148
II	298	200
Iv	392	263

17. Critical Construction Areas

- a. Proper placement and length.
- b. Permanent reference point.
- c. Removal of broken/collapsed piles.
- d. Achieving design bearing capacity.

18. NDOT Tests

- a. Test pile.

- b. Bearing capacity.
 - c. Pile Driving Analyzer.
19. Inspector's Records and Forms
- a. Pile Application
 - b. Hammer Data Sheet

703.02 MATERIAL REQUIREMENTS

- 1.. The Department's Geotechnical Section in the Materials and Research Division provides guidance and geotechnical designs for our projects. Some county bridge projects are completely designed by consultants including pile foundations. When a consultant design fails, i.e., bearing cannot be achieved, the Construction Division should be the first point of contact to determine how to correct a failed design.

703.03 EQUIPMENT

1. Diesel Hammers
- a. Generally, single acting diesel hammers are the mainstay of contractors for pile driving. Occasionally however, a contractor will request the use of an "air" or "hydraulic" operated hammer. In addition, there are a few "double acting" hammers in use. A wave equation analysis will be required for approval of all hammers.
 - b. One manufacturer of hammers uses one size hammer barrel and places different sized rams inside. Therefore, the MKT "DE" series hammers need to be field verified for ram mass (weight). A check is accomplished by having the contractor stand the hammer upright (in the driving position) and measuring down from top of the barrel to top of the ram. Verify the ram mass (weight) shown on the Hammer Data sheet as follows:

Ram Mass (kg)	Ram Distance (meter)	Ram Mass (tons)	Ram Distance (ft)
907	1.9	1	6.25
1270	1.2	1.4	4.0
1497	0.7	1.65	2.3
1814	180 mm	2.0	0.6

2. Bearing and Penetration
- a. Penetration Requirements
 - (i) Design pile length is a calculated value based on design bearing and soil conditions. One factor which enters into the calculation is the potential for scour. Obviously, any soil which is eroded during a flood event represents a loss in bearing capacity and foundation stability. **For this reason "minimum penetration" is extremely important.**
 - (ii) A depth of expected scour is typically shown on the Bridge Geology sheet in the plans. In general, streams with large drainage areas and sand or gravel stream beds are quite

susceptible to scour while streams with small drainage areas and heavy clay stream beds are less susceptible to scour.

- (iii) When doubt exists concerning the amount of probable scour or minimum pile penetration required, the Construction Division should be consulted. If greater penetration is required, it will be achieved by boring holes to receive the piles, jetting or using a different hammer. If penetration achieved is satisfactory, piles will be cut off.

3. Dynamic Pile Analyzer

- a. The Materials & Research Division has a pile analyzer available for driving evaluations. The pile analyzer will evaluate the bearing, based on energy delivered to a pile as it is being driven.
- b. There are two situations where the analyzer should be used:
 - Case 1. Contract documents require pile to be driven with the analyzer.
 - Case 2. Pile do not achieve bearing and there are unresolvable questions or conditions observed during driving.

703.04 MATERIAL REQUIREMENTS

703.05 CONSTRUCTION METHODS

1. Pile Driving Constraints

- a. Piles shall not be driven within 25 ft (15 m) of freshly placed concrete. Normally piles may not be driven near new concrete until three days after the concrete was placed.

2. Splicing Pile--Welding Steel Pile

- a. *SSHC Section 708* requires that all welds conform to the Structural Welding Code ANSI/AASHTO/AWS D1.5 of the American Welding Society.
- b. Only Shielded Metal Arc Welding (SMAW) will be permitted for welding steel piles.

3. Steel Pile Cutoffs

- a. If the contractor feels the cutoff is long enough that they may use it on some future project, the Heat number should be placed on the cutoff and a number to indicate the project it came from.

4. Pile Groups/Categories

- a. Selecting the type of pile to be used and estimating its necessary length are fairly difficult tasks that require good judgment.

- b. Piles can be divided into two major groups, depending on their length and the mechanisms of load transfer to the soil:
 - (i) End Bearing Piles
 - (1) If a strong soil stratum is within a reasonable depth, then piles can be extended to the stratum and achieve the ultimate bearing capacity.
 - (ii) Friction Piles
 - (1) The ultimate bearing capacity is achieved through the skin friction. The length of friction piles depends on the shear strength of the soil, the applied load and pile size. In clayey soils, the resistance to applied load is caused by adhesion.

- c. Piles are also divided into two different categories depending on their interaction with the soil:
 - (i) Displacement Pile:
 - (1) The effect of displacement pile on the soil is, it increases the lateral ground stress. It displaces cohesion-less soils, remolds and weakens cohesive soils temporarily. If displacement piles are used for cohesive soil, setup time in sensitive clays may be up to six months.
 - (2) Typical types of displacement piles are closed end steel pipe pile and concrete pile.
 - (ii) Non-displacement Pile:
 - (1) Opposite of the displacement pile, it minimizes disturbance to the soil.
 - (2) Typical types of non-displacement piles are open-end steel pipe pile and steel H pile. It should be mentioned open steel pipe is not suited for friction piles in coarse granular soils.

Weights of Prestressed Concrete Bearing Piling

For computing bearing capacity required on Materials & Research Pile Record spreadsheet

Pile Type	Constant Section	Tapered Section
	Wt. per Lin. Ft. (Pounds)	Total Weight (Pounds)
I	148	None
II	200	None
III	173	None
IV	212	None
V	124	1740
VI	169	2500
VII	221	2950

This table is based on and is for use only with Standard Plan 1720-C-R2.

Steel Pipe Pile Data

	ARMCO		Union Metal
Size O.D. (ins)	12	12 ³ / ₄	12 (Nominal)
Wall T. (ins.)	0.188	0.188	7 Ga.
Wt. per Lin. Ft. (lbs.)	23.72	25.16	25.3
Conc. per Lin. Ft. (C.Y.)	0.0273	0.0309	0.0255
Union Metal 30' tapered Sec. Type F Total Wt. 589 Lbs. Conc. 0.55 Cu. Yd.			
Size O.D. (ins)	14		14 (Nominal)
Wall T. (ins.)	0.188		7 Ga.
Wt. per Lin. Ft. (lbs.)	27.66		29.5
Conc. per Lin. Ft. (C.Y.)	0.0375		0.0350
Union Metal 40 foot tapered Sec. Type F Total Wt. 895 Lbs. Conc. 0.95 Cu. Yd.			
For Raymond step tapered pile, contact Geotechnical Section, Materials & Research.			

- d. The following guidelines for Single Acting Diesel Hammer are provided to assist you. If there is a need for a different type of hammer inspection guideline, please contact the Geotechnical Section.
 - e. It is very important to field check the hammer systems provided by the contractor to the hammer data sheets after they are approved by the Geotechnical Section. Prior to pile driving, please verify cap weight and size and condition of the hammer cushion material as shown on the hammer data sheets.
5. Inspection of Piles Prior to and During Installation
- a. The inspection will be different for each type of pile. Shop plans are required for sheet piles, but usually are not required for H-piles, concrete-piles or pipe-piles.
 - b. When MSE walls are being constructed, at times the soil conditions may require additional considerations. A note is sometimes included on our plans that states the MSE Wall Must Be Built Before Piles Are Driven. This note is usually applicable when the embankment behind the MSE wall is constructed as a fill. The note also usually specifies that the MSE wall cannot be constructed until the embankment has reached 95+% of its anticipated settlement. The concern here is that the granular backfill material will settle further and the embankment is also able to settle some additional amount due to the granular backfill load. The combined effect on the piling is to cause a downward load on the piling that will reduce the piling's capacity to resist the live and dead loads from the roadway.
 - c. Battered piles are driven at 1 ft. offset per 12 ft. of length or 3.33 ft. offset in 40 ft.
6. Precast Concrete Piles
- a. The following is a list of items for prestressed concrete piles to be inspected at the construction site:
 - (i) The piles should be of the specified length and section. The inspector must be assured that a minimum concrete strength has been obtained. If the piles are to be spliced on the site, the splices should meet the specified requirements (type, alignment, etc.).

- (ii) Piles should be inspected for cracks or spalling. There should be no evidence that any pile has been damaged during shipping to the site, or during unloading of piles at the site. Lifting hooks are generally cast into the piling at pick-up points. Piles should be unloaded by properly sized and tensioned slings attached to each lifting hook.
- (iii) The piles should be stored properly. When piles are being placed in storage, they should be stored above ground on adequate blocking in a manner which keeps them straight and prevents undue bending stresses.
- (iv) The contractor should lift the piles into the leads properly and safely. Cables looped around the pile are satisfactory for lifting. Chain slings should never be permitted. Cables should be of sufficient strength and be in good condition. Frayed cables are unacceptable and should be replaced. For shorter piles, a single pick-up point may be acceptable. The pick-up point locations should be as specified by the casting yard. For longer piles, two or more pick-up points at designated locations may be required.
- (v) The pile should be free to twist and move laterally in the helmet.
- (vi) Piles should have no noticeable cracks when placed in leads or during installation. Spalling of the concrete at the top or near splices should not be evident.

7. Steel H-Piles

- a. The following is a list of items for steel piles should be inspected at the construction site:
 - (i) The piles being driven must be oriented with flanges in the correct direction as shown on the plans. Because the lateral resistance to bending of H-piles is considerably more in the direction perpendicular to flanges, the correct orientation of H-piles is very important.
 - (ii) The piles should be of the specified steel grade, length, or section/weight.
 - (iii) Pile points, if required for pile toe protection, should be as specified.
 - (iv) Splices should be either proprietary splices or full penetration groove welds as specified. The top and bottom pile sections should be in good alignment before splicing.
 - (v) Pile point attachments and splices must be welded properly.
 - (vi) There should be no observable pile damage, including deformations at the pile head.

8. Steel Pipe Piles
 - a. The following should be inspected at the construction site:
 - (i) The piles should be of specified steel grade, length, or minimum section/weight (wall thickness) and either seamless or spiral welded as specified.
 - (ii) Piles should be driven either open-ended or closed-ended. Closed-ended pipe piles should have bottom closure plates or conical points of the correct size (diameter and thickness) and be welded on properly, as specified. Open-end pipe piles should have cutting shoes that are welded on properly.
 - (iii) The top and bottom pile sections should be in good alignment before splicing. Splices or full penetration groove welds should be installed as specified.
 - (iv) There should be no observable pile damage, including deformations at the pile head. After installation, closed-end pipes should be visually inspected for damage or water prior to filling with concrete.
9. Steel Sheet Piles
 - a. The sheet piles must meet thickness, section models, steel grade, length and width requirements as shown in our plans.
 - b. Sheet pile length should be measured so that analysis of obstructions to driving can be properly accomplished.
 - c. Sheet piles should be driven plumb or at the angle shown in the plans.
10. Inspection of Driving Equipment
 - a. A typical driving system consists of crane, leads, hammer, hammer cushion, helmet, and in the case of concrete piles, a pile cushion. Each component of the drive system has a specific function and plays an important role in the pile installation. The project plans and specifications may specify or restrict certain items of driving equipment. The Geotechnical Section will approve the contractor's driving equipment and determine conformity with the plans and specifications. The inspector must be sure the equipment used is what was approved.
 - b. The following checklist will be useful in the inspection of driving equipment before driving:
 - (i) The pile driving hammer should be the specified type/size.
 - (1) The inspector should make sure for single acting air/steam or hydraulic hammers that the contractor uses the proper size external power source and that, for adjustable stroke hammers, the stroke necessary for the required energy be obtained. For double acting or differential air/steam or hydraulic hammers, the contractor must again obtain the proper size external power source and the operating pressure and volume must meet the hammer manufacturer's specification.

- (ii) The hammer cushion being used should be checked to confirm it is of the approved material type, size and thickness.
 - (1) The main function of the hammer cushion is to protect the hammer itself from fatigue and high frequency accelerations which would result from steel to steel impact with the helmet and/or pile. The hammer cushion should have the proper material and same shape/area to snugly fit inside the helmet (drive cap). If the cushion diameter is too small, the cushion will break or badly deform during hammer blows and become ineffective. The hammer cushion must not be excessively deformed or compressed. Some air/steam hammers rely upon a certain total thickness (of cushion plus striker plate) for proper valve timing. Hammers with incorrect hammer cushion thickness may not operate, or will have improper kinetic energy at impact. Since it is difficult to inspect this item once the driving operation begins, it should be checked before the contractor starts pile driving on a project as well as periodically during production driving on larger projects.
- (iii) The helmet (drive cap) should properly fit the pile.
 - (1) The purpose of the helmet is to hold the pile head in alignment and transfer the impact concentrically from the hammer to the pile. The helmet also houses the hammer cushion, and must accommodate the pile cushion thickness for concrete piles. The helmet should fit loosely to avoid transmission of torsion or bending forces, but not so loosely as to prevent the proper alignment of hammer and pile. Helmets should ideally be of roughly similar size to the pile diameter. Although generally discouraged, spacers may be used to adapt an oversize helmet, provided the pile will still be held concentrically with the hammer. A properly fitting helmet is important for all pile types, but is particularly critical for precast concrete piles. A poorly fitting helmet often results in pile head damage. Check and record the helmet weight for conformance to wave equation analysis or for future wave equation analysis. Larger weights will reduce the energy transfer to the pile.
- (iv) The pile cushion should be of correct type material and thickness for concrete piles.
 - (1) The purpose of the pile cushion is to reduce high compression stresses, to evenly distribute the applied forces to protect the concrete pile head from damage, and to reduce the tension stresses in easy driving. Pile cushions for concrete piles should have the required thickness determined from a wave equation analysis but not less than 4 inches (100 mm). A new plywood, hardwood, or composite wood pile cushion, which is not water soaked, should be used for every pile. The cushion

material should be checked periodically for damage and replaced before excessive compression (more than half the original thickness), burning or charring occurs. Wood cushions may take only about 1,000 to 2,000 blows before they deteriorate. During hard driving, more than one cushion may be necessary for a single pile. Longer piles or piles driven with larger hammers may require thicker pile cushions.

- (v) Predrilling, jetting or spudding equipment, if specified or permitted, should be available for use and meet the requirements. The depth of predrilling, jetting or spudding should be very carefully controlled so that it does not exceed the allowable limits. Predrilling, jetting, or spudding below the allowed depths will generally result in a reduced pile capacity, and the pile acceptance may become questionable.
- (vi) A lead system must be used.
 - (1) The leads perform the very important function of holding the hammer and pile in good alignment with each other. Poor alignment reduces energy transfer as some energy is then imparted into horizontal motion. Poor alignment also generally results in higher bending stresses and higher local contact stresses which can cause pile damage. This is particularly important at end of driving when driving resistance is highest and driving stresses are generally increased.

11. Inspection of Driving Equipment During Installation

- a. The main purpose of inspection is to assure that piles are installed so that they meet the driving criteria and the pile remains undamaged. The driving criteria is often defined as a minimum driving resistance as measured by the blow count in blows per inch. The driving criteria is to assure that piles have the desired capacity. However, the driving resistance is also dependent upon the performance of the pile driving hammer. The driving resistance will generally be lower when the hammer imparts higher energy and force to the pile, and the driving resistance will be higher if the hammer imparts lower energy and force to the pile. High driving resistances can be due either to soil resistance or to a poorly performing hammer. Thus, for the inspector to assure that the minimum driving criteria has been met and, therefore, the capacity is adequate, the inspector must evaluate if the hammer is performing properly.
- b. Each hammer has its own operating characteristics; the inspector should not blindly assume that the hammer on the project is in good working condition. In fact, two different types of hammers with identical energy rating will not drive the same pile in the same soil with the same driving resistance. In fact, two supposedly identical hammers (same make and model) may not have similar driving capability due to several factors including differing friction losses, valve timing, air supply hose type-length-condition, fuel type and intake amount, and other maintenance status items. The inspector should become familiar with the proper

operation of the hammer(s) used on site. The inspector may wish to contact the hammer manufacturer or supplier who generally will welcome the opportunity to supply further information.

12. Single Acting Diesel Hammers

- a. Determine/confirm that the hammer is the correct make and model. Check for and record any identifying labels as to hammer make, model and serial number.
- b. Inspect the recoil dampener for condition and thickness. If excessively worn or improper thickness (consult manufacturer) it should be replaced. If the recoil dampener is too thin, the stroke will be reduced. If it is too thick, or if cylinder does not rest on dampener between blows, the ram could blow out the hammer top and become a safety hazard.
- c. Check that lubrication of all grease nipples is regularly made. Most manufacturers recommend the impact block be greased every half-hour of operation.
- d. As the ram is visible between blows, check the ram for signs of uniform lubrication and ram rotation. Poor lubrication will increase friction and reduce energy to the pile.
- e. Determine the hammer stroke, especially at end of driving or beginning of restrike. A “jump stick” attached to the cylinder is a safety hazard and should not be used. The stroke can be determined by a saximeter which measures the time between blows and then calculates the stroke. The hammer stroke can also be calculated from this formula if the number of blows per minute (bpm) is manually recorded.
$$h \text{ [meters]} = (4400/[\text{bpm}^2]) - 0.90$$
- f. The calculated stroke may require correction for batter or inclined piles. The inspector should always observe the ram rings and visually estimate the stroke using the manufacturer’s chart.
- g. As the driving resistance increases, the stroke should also increase. At the end of driving, if the ram fails to achieve the correct stroke (part of the driving criteria from a wave equation analysis), the cause could be lack of fuel. Most hammers have adjustable fuel pumps. Some have distinct fuel settings, others are continuously variable, and some use a pressure pump. Make sure the pump is on the correct fuel setting or pressure necessary to develop the required stroke. The fuel and fuel line should be free of dirt or other contaminants. A clogged or defective fuel injector will also reduce the stroke and should be replaced if needed.
- h. Low strokes could be due to poor compression caused by worn or defective piston or anvil rings. Check compression by raising the ram, and with the fuel turned off, allowing the ram to fall. The ram should bounce several times if the piston and anvil rings are satisfactory.
- i. Watch for signs of preignition. When a hammer preignites, the fuel burns before impact, requiring extra energy to compress gas and leaving less energy to transfer to the pile. In long sustained periods of driving, or if the wrong fuel with a low flash point is used, the hammer could overheat and preignite. When preignition occurs, less energy is transferred and the

driving resistance rises, giving a false indication of high pile capacity. If piles driven with a cold hammer drive deeper or with less hammer blows, or if the driving resistances decrease after short breaks, preignition could be the cause and should be investigated. Dynamic testing is the preferable method to check for preignition.

- j. For some diesel hammers, the total thickness of hammer cushion and striker plate must match the hammer manufacturer's recommendation and the hammer cushion cavity in the helmet for proper fuel injection and hammer operation. This total thickness must be maintained.
- k. Make sure the helmet stays properly seated on the pile and that the hammer and pile maintain alignment during operation.
- l. The hammer hoist line should always be slack, with the hammer's weight fully carried by the pile. Excessive tension in the hammer hoist line is a safety hazard and will reduce energy to the pile. Leads should always be used.
- m. Some manufacturers void their warranty if the hammer is consistently operated above 100 blows per 250 mm of penetration beyond short periods, such as those required when toe bearing piles are driven to rock. Therefore, in prolonged hard driving situations, it may be more desirable to use a larger hammer or stiffer pile section.
- n. Common problems and problem indicators for single acting diesel hammers are presented in the following table.

COMMON PROBLEMS AND PROBLEM INDICATORS FOR SINGLE ACTING DIESEL HAMMERS (from Williams Earth Sciences, 1995)	
Common Problems	Indicators
Water in fuel.	Hollow sound, white smoke.
Fuel lines clogged.	No smoke or little gray smoke.
Fuel pump malfunctioning.	Inconsistent ram strokes, little gray smoke or black smoke.
Fuel injectors malfunctioning.	Inconsistent ram strokes, little gray smoke or black smoke.
Oil low.	Blows per minute rate is lower than specified.
Oil pump malfunctioning.	Blows per minute rate is lower than specified.
Water in combustion chamber.	Hollow sound, white smoke.
Piston rings worn.	Low strokes.
Tripping device broken.	Pawl or pin used to lift piston does not engage piston. Pawl engages but does not lift piston.
Overheating.	Paint and oil on cooling fins start to burn/sound changes.

M. Field Driving Problem

In the following table, there is a list of common field problems and possible solutions.

COMMON PILE INSTALLATION PROBLEMS & POSSIBLE SOLUTIONS	
Problem	Possible Solutions
Piles encountering refusal driving resistance (blow count) above minimum pile penetration requirements.	Have wave equation analysis performed and check the pile has sufficient drivability and that the driving system is matched to the pile. If the pile and driving system are suitably matched, check driving system operation for compliance with manufacturer's guidelines. If no obvious problems are found, dynamic measurements should be made to determine if the problem is driving system or soil behavior related. Driving system problems could include preignition, preadmission, low hammer efficiency, or soft cushion. Soil problems could include greater soil strength than anticipated, temporarily increased soil resistance with later relaxation (requires restrike to check), large soil quakes, or high soil damping.
Piles driving significantly deeper than estimated pile penetration depths.	Soil resistance at the time of driving probably is lower than anticipated or driving system performance is better than anticipated. Have wave equation analysis performed to assess ultimate pile capacity based on the blow count at the time of driving. Perform restrike tests after an appropriate waiting period to evaluate soil strength changes with time. If the ultimate capacity based on restrike blow count is still low, check drive system performance and restrike capacity with dynamic measurements. If drive system performance is as assumed and restrike capacity low, the soil conditions are weaker than anticipated. Foundation piles will probably need to be driven deeper than originally estimated or additional piles will be required to support the load. Contact the structural engineer/designer for recommended change.
Abrupt change or decrease in driving resistance (blow count) for bearing piles.	If borings do not indicate weathered profile above bedrock/bearing layer, then pile toe damage is likely. Have wave equation analysis performed and evaluate pile toe stress. If calculated toe stress is high and blow counts are low, a reduced hammer energy (stroke) and higher blow count could be used to achieve capacity with a lower toe stress. If calculated toe stress is high at high blow counts, a different hammer or pile section may be required. For piles that allow internal inspection, reflect light to the pile toe and tape the length inside the pile for indications of toe damage. For piles that cannot be internally inspected, dynamic measurements could be made to evaluate problem or pile extraction could be considered for confirmation of a damage problem.
Driving resistance (blow count) significantly lower than expected during driving.	Review soil borings. If soil borings do not indicate soft layers, pile may be damaged below grade. Have wave equation analysis performed and investigate both tensile stresses along pile and compressive stresses at tie. If calculated stresses are within allowable limits, investigate possibility of obstructions/uneven toe contact on hard layer or other reasons for pile toe damage. If pile was spliced, re-evaluate splice detail and field splicing procedures for possible splice failure.

COMMON PILE INSTALLATION PROBLEMS & POSSIBLE SOLUTIONS	
Problem	Possible Solutions
Vertical (heave) or lateral movement of previously installed piles when driving new piles.	Pile movements likely due to soil displacement from adjacent pile driving. Contact geotechnical engineer for recommended action. Possible solutions include re-driving of installed piles, change in sequence of pile installation, or predrilling of pile locations to reduce ground movements. Lateral pile movements could also result from adjacent slope failure in applicable conditions.
Piles driving out of alignment tolerance.	Piles may be moving out of alignment tolerance due to hammer-pile alignment control or due to soil conditions. If due to poor hammer-pile alignment control, a pile gate, template or fixed lead system may improve the ability to maintain alignment tolerance. Soil conditions such as near surface obstructions (see subsequent section) or steeply sloping bedrock having minimal overburden material (pile point detail is important) may prevent tolerance from being met even with good alignment control. In these cases, survey the as-built condition and contact the Geotechnical engineer for recommended action.
Piles driving out of location tolerance.	Piles may be moving out of location tolerance due to hammer-pile alignment control or due to soil conditions. If due to poor hammer-pile alignment control, a pile gate, template or fixed lead system may improve the ability to maintain location tolerance. Soil conditions such as near surface obstructions (see subsequent section) or steeply sloping bedrock having minimal overburden material (pile point detail is important) may prevent tolerances from being met even with good alignment control. In these cases, survey the as-built condition and contact the Geotechnical engineer for recommended action.
Piles encountering shallow obstructions.	If obstructions are within 3 feet of working grade, obstruction excavation and removal is probably feasible. If obstructions are at deeper depth, are below the water table, or the soil is contaminated, excavation may not be feasible. Spudding or predrilling of pile locations may provide a solution with method selection based on the type of obstructions and soil conditions.
Pile encountering obstructions at depth.	If deep obstructions are encountered that prevent reaching the desired pile penetration depth, contact the structural engineer/designer for remedial design. Ultimate capacity of piles hitting obstructions should be reduced based upon pile damage potential and soil matrix support characteristics. Additional foundation piles may be necessary.
Concrete piles develop partial horizontal cracks in easy driving.	Check hammer-pile alignment since bending may be causing the problem. If the alignment appears to be normal, tension and bending combined may be too high. The possible solution is as above with complete cracks.
Concrete pile spalling or slabbing near pile head.	Have Geotechnical Section determine pile head stress for observed blow count and compare with allowable stresses. If high calculated stress, add pile cushioning. If low calculated stress, investigate pile quality, hammer performance, hammer-pile alignment.
Concrete piles develop complete horizontal cracks in easy driving.	Have Geotechnical Section determine tension stresses along pile for observed blow counts. If high calculated tension stresses, add cushioning or reduce stroke. If low calculated tension stresses, check hammer performance and/or perform measurements.
Concrete piles develop complete horizontal cracks in hard driving.	Have Geotechnical Section determine tension stresses along pile. If high calculated tension stresses, consider heavier ram. If low calculated tension stresses, take measurements and determine quakes which are probably higher than anticipated.
Concrete piles develop complete horizontal cracks in hard driving.	Have Geotechnical Section determine tension stresses along pile. If high calculated tension stresses, consider heavier ram. If low calculated tension stresses, take measurements and determine quakes which are probably higher than anticipated.
Concrete piles develop partial horizontal cracks in easy driving.	Check hammer-pile alignment since bending may be the problem. If alignment appears to be normal, tension and bending combined may be too high; solution will then be the same as for complete cracks above.

COMMON PILE INSTALLATION PROBLEMS & POSSIBLE SOLUTIONS	
Problem	Possible Solutions
Steel pile head deforms, timber pile top mushrooms.	Check helmet size/shape; check steel strength; check evenness of pile head, banding of timber pile head. If okay, have Geotechnical Section determine pile head stress. If calculated stress is high, reduce hammer energy (stroke) for low blow counts; for high blow counts, different hammer or pile type may be required.
Unexpectedly low blow counts during pile driving.	Investigate soil borings; if soil borings do not indicate soft layers, pile may be damaged below grade. Have Geotechnical Section investigate both tensile stresses along pile and compressive stresses at toe. If calculated stresses are acceptable, investigate possibility of obstructions/uneven toe contact on hard layer or other reasons for pile toe damage.
Higher blow count than expected.	Have the Geotechnical Section review the wave equation analysis and check that all parameters were reasonably considered. Check hammer and driving system. If no obvious defects are found in driving system, field measurements should be taken. Problem could be preignition, preadmission, low hammer efficiency, soft cushion, large quakes, high damping, greater soil strengths, or temporarily increased soil resistance with later relaxation.
Lower blow count than expected.	Probably soil resistance is lower than anticipated. Have the Geotechnical Section assess soil resistance. Perform restrrike testing (soil resistance may have been lost during driving), establish setup factor and drive to lower capacity. Hammer performance may also be better than anticipated, check, by measurement.
Diesel hammer stroke (bounce chamber pressure) higher than calculated.	The field observed stroke exceeds the calculated stroke by more than 10%. Compare calculated and observed blow counts. If observed are higher, soil resistance is probably higher than anticipated. If blow counts are comparable, have the Geotechnical Section reanalyze with higher combustion pressure to match observed stroke and assure that preignition is not a problem, e.g., by measurements.
Diesel hammer stroke (bounce chamber pressure) lower than calculated.	The field observed stroke is less than 90% of the calculated stroke. Check that ram friction is not a problem (ram surface should have well lubricated appearance). Compare calculated and observed blow count. If observed one is lower, soil resistance is probably lower than anticipated. If blow counts are comparable, reanalyze with lower combustion pressure to match observed hammer stroke.
Cannot find hammer in data file.	See if there is a hammer of same type, similar ram weight and energy rating and modify its data.
Cannot find an acceptable hammer to drive pile within driving stress and driving resistance limits.	Both calculated stresses and blow counts are too high. Increase pile impedance or material strength or redesign for lower capacities. Alternatively, check whether soil has potential for setup. If soil is fine grained or known to exhibit setup gains after driving, then end of driving capacity may be chosen lower than required. Capacity should be confirmed by restrrike testing or static load testing.

703.06 METHOD OF MEASUREMENT

703.07 BASIS OF PAYMENT

704.00 CONCRETE CONSTRUCTION

704.01 DESCRIPTION

1. This section of the Specifications deals with the construction of structures composed of reinforced Portland cement concrete. This work includes constructing, setting and supporting the forms, and handling, placing, finishing and curing the concrete for bridges, box culverts, arch culverts, headwalls, retaining walls and steps, and the miscellaneous structures listed in the incidental construction portion of the Specifications.

SSHC References:

- Section 704 Concrete Construction*
- Section 1002 Portland Cement Concrete*
- Section 1010 White Opaque Polyethylene Film and
Burlap--Polyethylene Sheeting For Curing Concrete*
- Section 1011 Burlap For Curing Concrete*
- Section 1014 Joint Sealing Filler*
- Section 1015 Preformed Joint Filler*
- Section 1016 Preformed Polychloroprene Elastomeric Joint Seals*
- Section 1033 Aggregates*

Inspection Crew: Lead Inspector

Inspection Equipment: Slump Cone
Air Meter (pressure)
Cylinder Molds and Lids
Rod
Mallet
Strike Off Bar
Ruler

Placement Procedures:

1. Preplacement check of equipment.
2. Check condition and placement of steel.
3. Check Form setting and alignment. Verify location coordinates and orientation.
4. Have contractor wet grade and forms before concrete placement.
5. Test concrete for air content, slump, and make cylinders when mix changes, at a minimum according to [Materials Sampling Guide](#).
6. Watch concrete placement for compliance with specifications. Do not allow free fall greater than 5 ft (1.5 m).
7. Do not use water as a finishing aid; use an approved chemical finishing aid/evaporation retardant.
8. Check curing operation.

NDOT Tests:

1. ASTM C31 Making and Curing concrete test specimens.
2. ASTM C143 Slump of Portland Cement Concrete.
3. ASTM C172 Sampling of Fresh Concrete.
4. ASTM C231 Air Content of Freshly Mixed Concrete by the Pressure Method.

704.02 MATERIAL REQUIREMENTS

1. Composition of Concrete
 - a. The class of concrete to be used in the work is specified in the plans or special provisions and shall be one of those described in *SSHC Subsection 1002.02*. In the event that the contractor has a choice of several classes, the contractor is required to advise the Project Manager by letter of the one to be used. This information should be obtained prior to any concrete construction to allow engineering personnel to make provisions for necessary inspection and testing. The contractor may not change classes of concrete during construction without the written permission of the Project Manager (Note 47B mixes need to be submitted to Materials & Research for approval)
 - b. *SSHC Subsection 1002.03* prescribes requirements for concrete materials. The Contractor's responsibility for material requirements may be summarized as follows:
 - (i) Check with the Approved Product List for as to the approval of cement, , and curing compound. See [Materials Sampling Guide](#) for aggregate testing requirements.
 - (ii) Submit samples of non-approved materials to the Central Testing Laboratory in sufficient time before use to allow time to receive results. The size and frequency of samples are provided in the [Materials Sampling Guide](#).
 - (iii) Materials for which approval has not been received must not be used in the work.
 - c. The inspector is concerned not only with the acceptance of materials but also with the storage of materials. Bag cement shall be stored in a dry location. If stacked more than 8 bags high for a period of time the lower layers take on a "warehouse set" and should not be used. Cement stored over 90 days must be retested before use.
2. Admixtures
 - a. Admixtures are those ingredients in concrete other than Portland cement, water, and aggregates, that are added to the mixture immediately before or during mixing. Admixtures typically encountered on our jobs can be classified by function as follows:
 - (i) Air entraining admixtures
 - (ii) Water reducing admixtures
 - (iii) Set retarding admixtures (optional)

- (iv) Set accelerating admixtures (optional)
 - (v) Finely divided and permeability mineral admixtures (When required by contract)
 - (vi) Coloring agents (When required by contract)
 - b. The amount of any admixture used in a mix should be as recommended by the manufacturer. Effectiveness of an admixture depends upon such factors as type, brand, and amount of cement; water content; aggregate shape; gradation and proportions; mixing time; slump; and temperatures of concrete and air.
 - c. Concrete with a low air content shall not be incorporated into work. One addition of air entraining admixture is allowed at the site.
 - d. Concrete with a high air content should not be incorporated into work except under extreme circumstances. If low compressive strengths result, the concrete may be required to be removed and replaced. (*SSHC Subsection 106.05*)
3. Air Entraining Admixtures
- a. Air entraining admixtures are used to purposely entrain microscopic air bubbles in concrete. Air entrainment will dramatically improve the durability of concrete exposed to moisture during cycles of freezing and thawing. Entrained air greatly improves concrete's resistance to surface scaling caused by chemical deicers.
 - b. Rules-of-Thumb
 - (i) As cement content increases, air agent must increase to maintain equal entrained air.
 - (ii) As cement fineness increases, the amount of air agent must increase to maintain equal entrained air.
 - (iii) As coarse aggregate size decreases, the air content increases for a given amount of air agent.
 - (iv) As fine aggregate volume increases, the air content increases for a given amount of air agent.
 - (v) As mixing water increases, the air content increases for a given amount of air agent.
 - (vi) Air entraining admixtures should be introduced into mix at the plant, but additional may be added at the site to adjust mix for correct air content.
 - (vii) Air entraining admixtures should (usually) be added to the front of the truck at the plant. If corrosion inhibiting admixture is used, air entraining agents should be added to the back of the truck.

4. Water Reducing Admixtures
 - a. Water reducing admixtures are used to reduce the quantity of mixing water required to produce concrete of a certain slump or reduce the water/cement ratio. Regular water reducers reduce water content by about 5% to 10%.
 - b. Adding a water reducing admixture to a mix without reducing water content can produce a mixture with a much higher slump.
 - (i) Rules-of-Thumb
 - (1) Typically, water reducing admixtures do not reduce the rate of slump loss; in most cases, it is increased. Rapid slump loss results in reduced workability and less time to place concrete at the higher slump.
 - (2) Typically, water reducing admixtures decrease bleed water because less water is available.
 - (3) Certain types of sulfate starved Portland cements may cause false set with certain brands of water reducers. Typically, water reducers contain lignosulfonates and these sulfates are easily attracted by sulfate starved cements. This action may cause early false set.
 - (4) Despite reduction in water content, water reducing admixtures can cause a significant increase in drying shrinkage.
5. High Range Water Reducing Admixtures (Type F) (optional)
 - a. They are added to concrete with low-to-normal slump and water content to make high slump "flowable" concrete. Flowable concrete is a highly fluid, but workable concrete that can be placed with little or no vibration and can still be free of excessive bleeding or segregation. Flowable concrete has applications:
 - (i) In areas of closely spaced and congested reinforcing steel.
 - (ii) In tremied concrete where "self consolidation" is desirable.
 - (iii) In pumped concrete to reduce pump pressure.
 - (iv) To produce low water/cement ratio - high strength concrete. High-range "super plasticizers" can reduce water content by about 12% to 30%.
 - b. Rules-of-Thumb
 - (i) The effect of most super plasticizers in increasing workability or flowable concrete is short lived. Typically, maximum is 30 to 60 minutes followed by a very rapid loss in workability.
 - (ii) Typically, super plasticizers are added as split treatments (part at the plant part at the site). Sometimes the addition is totally at the site.
 - (iii) Setting time may be affected depending on the brand used, dosage rate, and interaction with other admixtures.

- (iv) Excessively high slumps of 10 inches (250 mm) or more may cause segregation.
 - (v) High-slump, low water/cement super plasticized concrete has less dry-shrinkage than does high-slump high water/cement conventional concrete.
 - (vi) Effectiveness of super plasticizer is increased with an increased amount of cement and/or increased fineness of cement.
 - (vii) Effectiveness of water reducers on concrete is a function of their chemical composition, cement composition and fineness, cement content concrete temperature, and other admixtures being used.
 - (viii) Some water reducing admixtures, such as lignosulfonates, may also entrain some air in the mix.
6. Retarding Admixtures optional
- a. Retarding admixtures (retarders) are used to delay the initial set of concrete. High temperatures of fresh concrete 85°F (30°C) and up often cause an increased rate of hardening. For bridge decks, set retarders are required for temperatures over 60 degrees (F) (see section 706). Since retarders do not decrease the initial temperature of concrete, other methods of counteracting the effect of temperature must be used.
 - b. Rules-of-Thumb
 - (i) Retarders are sometimes used to delay initial set of concrete when difficult, long placement times, or unusual placement conditions exist.
 - (ii) Retarders offset the set acceleration effect of hot weather.
 - (iii) Retarders can be added at the site.
 - (iv) In general, some reduction in strength at early ages (one to two days) accompanies the use of retarders.
 - (v) Use of retarders must be closely monitored, because there is probably no single admixture which has caused more field problems.
 - (vi) If too much retarder has been used in a mix:
 - (1) Time will usually counter the effects.
 - (2) Be sure to maintain the cure during the added time.
7. Accelerating Admixtures (optional)
- a. Accelerating admixtures (accelerators) are used to accelerate the setting time and strength development of concrete at an early age. Strength development can also be accelerated by using:
 - (i) Type III "high-early" cement
 - (ii) Lowering water/cement ratio
 - (iii) Curing at controlled higher temperatures

- b. Calcium Chloride (CaCl_2) is the material most commonly used in accelerating admixtures. Besides accelerating strength gain, calcium chloride also causes an increase in drying shrinkage, potential reinforcement corrosion, discoloration, and potential scaling. Calcium Chloride should not be used on reinforced concrete.
 - (i) Rules-of-Thumb
 - (1) Always add calcium chloride in solution form as part of the mixing water.
 - (2) Calcium chloride is not an antifreeze agent. When used in allowable amounts, it will only reduce the freezing point of concrete by a few degrees (may cause deck cracks).
- 8. Finely Divided Mineral Admixtures
 - a. These admixtures are powdered or pulverized materials added to concrete to improve or change the properties (plastic or hardened) of concrete. Based on the mineral's chemical or physical properties, they are classified as: (1) Cementitious, (2) Pozzolans, (3) Pozzolanic and Cementitious, and (4) Nominally inert. Typical PCC mix designs use pozzolanic and cementitious minerals.
 - b. Pozzolanic Materials
 - (i) A pozzolan is a siliceous or aluminosiliceous material that in itself possesses little or no cementitious value but will, in finely divided form and in the presence of water, chemically react with the calcium hydroxide released by the hydration of Portland cement to form compounds possessing cementitious properties. Pozzolans include fly ash and silica fume.
 - c. Fly Ash (Class C & F)
 - (i) Fly ash is a finely divided residue that results from the combustion of pulverized coal in electric power plants.
 - d. Silica Fume
 - (i) Silica fume, also referred to as micro-silica or condensed silica fume, is another material that is used as a pozzolanic admixture. This light to dark gray powdery product is a result of the reduction of high-purity quartz with coal in an electric arc furnace.
 - (ii) Fly ash and silica fume have a spherical shape. Silica fume has an extremely small particle size (about 100 times smaller than the average cement particle). Although silica fume is normally in powder form, because of its small size and increased ease of handling the product is commonly available in liquid form.
 - (iii) Rules-of-Thumb
 - (1) Mixes containing fly ash will generally require less water (about 1% to 10%) for a given slump. Silica fume concrete requires more water for a given slump.
 - (2) The amount of air-entraining admixture required to obtain a specified air content is normally greater when fly ash or

silica fume is used. The amount of air-entraining admixture for a certain air content is a function of the fineness, carbon content and alkali content.

- (3) Fly ash will generally improve the workability of concretes of equal slump. However, fly ash in low slump concrete will tend to tear and have reduced workability. Silica fume tends to reduce workability, thus high-range water reducers are usually added to maintain workability.
- (4) Concrete using fly ash or silica fume generally shows less segregation and bleeding than plain concrete.
- (5) Use of fly ash will reduce the amount of heat buildup in concrete. Silica fume most likely will not reduce the heat of hydration, because typically high-range water reducers are used and they increase mass temperatures.
- (6) Use of fly ash will tend to generally retard the setting time of concrete. Silica fume alone will accelerate the setting time, however, high-range water reducers tend to offset this.
- (7) Use of fly ash generally aids the pumpability of concrete.
- (8) With adequate and correct curing, fly ash generally reduces for permeability. Silica fume is especially effective in this regard.

9. Concrete Temperatures

a. Recommended Concrete Temperatures

- (i) Since only dry insulation is effective, any insulation that has a propensity to absorb water or become saturated must be protected with a waterproof membrane. The insulation system must provide complete coverage and be secured to provide maximum protection during the full curing period.
- (ii) For typical protection applications, insulated forms must be left undisturbed for 96 hours before being removed.

b. Checking Temperature of Concrete

- (i) Record the temperature daily for 5 days following the pour. Temperature readings below 50°F (10°C) during the first 48 hours should be entered in the Daily Work Report and reported to the District Construction Engineer for evaluation of possible damage or price adjustment.
- (ii) A thermocouple with recorder can also be used to document temperatures during curing.

- c. Temperature Field Documentation
 - (i) The temperature of concrete should be taken as soon as concrete is placed. It should be taken when the first load is placed. Additional checking is warranted if the temperature is running at or near maximum. Air temperature should also be taken about the same time as the concrete temperature.

704.03 CONSTRUCTION METHOD

- 1. Concrete Plant Inspector's Checklist
 - a. Batching equipment should be certified with the National Ready Mixed Concrete Association (NRMCA) Quality Control Manual - Section 3 - Plant Certification. (See *SSHC Subsection 1002.03*) In addition to proper plant calibration, the inspector should verify that each truck mixer used on the job has a current certification as required by *SSHC Section 1002*. It is good practice to inspect a random sample of ready mix trucks that will be used on the job, verifying that the certification accurately reflects the truck's condition. Truck certification numbers should be recorded in the DWR and will need to be re-verified at least every 30 days.
 - b. Batching and mixing should be limited to the lead truck until slump and air content have been tested for conformance with specifications. Contractors may make preliminary tests at the plant but project acceptance is based on job site tests. It is intended that the ready mix plant supply concrete to the construction site that conforms to all applicable specifications at the point where the acceptance sample is taken.
 - (i) *SSHC Table 1002.02*, Concrete Proportions, lists air content requirements.
 - (ii) If concrete is being delivered which deviates much from these target values, the contractor is responsible for taking corrective action to bring the mix to within target values. Even if the current mix is within specified limits. The intent of the tolerance is to provide latitude during placement for unforeseen changes in materials, mixes, and placement methods. Placing concrete "consistently" near a tolerance limit is not desirable and warrants additional sampling.
 - (iii) What is important, is the contractor's response to test results approaching tolerance limits. Continually having to add water and/or air agent to each load at the site will not be permitted. If such practice is occurring, the inspector shall notify the contractor (or whomever was designated as "the" responsible individual in charge of the concrete at the site.) Ultimately, it is the contractor's responsibility to initiate immediate corrective action.
 - c. Non-responsiveness on the contractor's part is reason to initiate sampling and testing of each truck or halt placement. The purpose for additional testing is to ensure that no noncomplying materials are incorporated into the project.

- d. In some cases admixtures, such as water reducers, are required to be added in split doses or sometimes totally at the site.
- e. All Structural Concrete
 - (i) At the start of each day's placement, no concrete is to be placed in the forms or on the deck until the first truck has been sampled, tested, and approved. Incorporation of materials from this truck will not be permitted unless desired air content is within specified limits. Continuous placement shall not begin until after test results indicate the material meets specified requirements.
 - (ii) If the first load is close to a limit value, it is recommended to sample and test the second load unless site experience indicates it is not necessary.
 - (iii) Initial startup test results (if taken from the truck chute) must account for method of placement. For example: If placement will be through a pump, air values should be on the high side of target to account for loss during pumping. Again, site/project experience should be factored in this decision. Sampling of concrete on a bridge deck needs to be taken at point of placement.
 - (iv) Routine acceptance testing will be at the frequency specified in the [Materials Sampling Guide](#).

NOTE: Only the Materials and Research Division has authority to approve decreasing (less frequent) testing frequencies from those listed in [Materials Sampling Guide](#). PLAN AHEAD and obtain approval for those cases where a variance would be reasonable.

- (1) For routine acceptance testing, obtain a representative sample at the last practical point before incorporation, but prior to consolidation.

NOTE: When concrete is placed by means other than directly from the back of the truck the sample shall be taken after the concrete has passed through the conveyance method being used. (This includes placement by bucket, belt, pumps, power buggies, etc.)

- (2) Routine acceptance sampling and testing does not require holding a truck until results are available. However, if there are obvious deficiencies, the inspector has the authority to hold that truck until test results are available.
- (3) Inspectors should be alert to obvious visual changes in consistency, with routine acceptance air and slump tests being made as noted above. Any load having questionable consistency should be checked for slump, and air content.

- (4) If noncomplying test results are found during routine acceptance sampling, no more material (from that truck or others) shall be incorporated until complying test results are obtained. When test results indicate noncomplying material:
 - (a) The rest of that load shall be rejected and not incorporated, unless adjustments can be made to bring it back into compliance.
 - i. In an attempt to bring noncomplying concrete into compliance, the supplier may make field adjustments (i.e.: add air entraining agent, or rotate the drum). Such "field" adjustments shall be an EXCEPTION and not the general rule and the 90 minute time restriction shall not be waived for any situation without the approval of the Portland Cement Concrete Engineer
 - (b) For all noncomplying test results the inspector shall immediately notify the contractor or their representative in charge of the concrete. This notification shall also inform the Contractor if noncomplying materials have been incorporated into the structure.
 - (c) If test results indicated noncomplying materials have been incorporated, the inspector shall make a note in the Daily Work Report indicating the test results, approximate volume incorporated, location the material was placed, and to whom the notification was given. The inspector should also note a noncomplying event on that particular truck's delivery ticket.
 - (d) When noncomplying materials are found, the inspector will: a) hold each truck, and b) initiate sampling and testing of each truck until loads meet specifications. At this point sampling and testing may return to normal project acceptance frequency.
- f. Specifications spell out requirements that materials must meet to be acceptable. Further, the [Materials Sampling Guide](#) identifies a frequency for sampling/testing and whether the test is an acceptance or assurance test.
 - (i) Authority for initially rejecting noncomplying materials and poor quality work performance is given to the inspector in *SSHC Subsection 106.05*. This rejection authority is only superseded by the Project Manager. There is an old saying to the effect "*We shall not knowingly incorporate noncomplying material into a project.*" This means exactly what it says and there is ample support in the specifications for this position.

- g. During placements, the inspector should alternate sampling among the various trucks involved in the operation.
 - h. If there is a specific truck which is identified as causing a problem with consistency, that truck shall be rejected from further use.
 - i. Transit mixers shall be completely emptied of wash water before reloading. If the truck's top fill hopper is washed after loading, no wash water shall be allowed to enter the mixer.
 - j. The inspectors will need to satisfy themselves regarding compliance with the specifications for the number of drum revolutions at mixing speed.
 - k. If water, air entrainment or other admixtures are added at the project site, acceptance testing will not be performed until all additions have been made AND required mixing has been completed following the change.
2. Falsework
- a. General: *SSHC Subsection 704.03*, paragraph 5.c requires the contractor to submit falsework plans when required or when certain conditions apply. These plans shall be prepared by an Engineer registered in the State of Nebraska. The contractor shall prepare falsework plans, as called for in plans or in the special provisions, and for the conditions listed in 704.03 paragraph 5.b
 - b. Falsework Inspection
 - (i) Contract requirements governing falsework construction are contained in *SSHC Subsection 704.03, paragraph 5*.
 - (ii) The Project Manager should observe the falsework as it is erected to ensure that:
 - (1) Only sound materials are used.
 - (2) Quality work is used.
 - (3) During concrete pour, the falsework will carry the load. (More than 1/2 inch movement is bad.)
 - c. By specification, a contractor is responsible for proper evaluation of the quality of their falsework materials. However, the Project Manager should not permit use of any material, when there is doubt as to the materials ability to safely carry the load. If there is any question, the contractor should be required to perform a load test or furnish other evidence of structural adequacy.
 - d. Timely inspection is essential. Falsework deficiencies should be brought to the contractor's attention at once. Deficiencies include:
 - (1) Poor quality work.
 - (2) Use of unsound or poor quality materials.

- (3) Construction which does not conform to the contractor's falsework drawings.
 - e. If the contractor fails to take corrective action, a noncompliance letter shall be issued. Corrective action will be required prior to placement of any additional dead or live load to the support structure.
3. Falsework Foundations
- a. Falsework piling should be driven to adequate bearing unless mudsills or spread footings can be founded on rock, shale, compact gravel, coarse sand, firm clays in natural beds, or well compacted fill.
 - (i) Falsework Piles
 - (1) The contractor is responsible for adequate foundation support. However, if requested, pile bearing values may be recommended by the wave equation.
 - (2) The pile bearing value required to support the design load must be shown on falsework drawings, and the pile driving operation must be inspected sufficiently to ensure that falsework piles attain required bearing.
 - b. Mudsills and Spread Footings
 - (i) Foundation material should be inspected before the footings are placed.
 - (ii) To ensure uniform soil bearing, falsework pads must be set on unyielding support. Material that provides a firm even surface, free of bumps or depressions within the pad bearing area. If necessary to obtain uniform bearing, a thin layer of sand may be used to fill in surface irregularities.
 - (iii) Continuous pads must be analyzed differently than individual pads, and the two should not be considered equivalent. A change from one to the other requires resubmittal to the Construction Division for review by the Bridge Division.
 - (iv) Falsework pads should be level. Benches in fill slopes should be cut into firm material, with the pad set well back from the edge of the bench.
 - (v) Many soils lose their supporting capacity when saturated. Adequate falsework construction must provide for drainage and protect pads from being undermined or ponded in water.

- c. Soil Load Test
 - (i) Project Managers should require the contractor to perform a soil bearing test if there is any doubt as to the ability of foundation material to support the falsework load without appreciable settlement. One method to evaluate in-situ bearing capacity is to perform a plate bearing test as per AASHTO T-222 (The above referenced method is not the only such test procedure, but is included to provide one method of determining in-situ capacity.)
- 4. Falsework Materials
 - a. One aspect of a falsework design and review is based on the use of undamaged, high-quality materials. Material strength values must be reduced if lower quality materials are to be used. Obviously, evaluation of the quality of materials actually furnished is an important, and essential, part of the falsework inspection procedure.
 - (i) Timber
 - (1) Inspecting falsework materials is necessary to prevent the use of materials which obviously do not meet the "undamaged high-quality" design criteria.
 - (2) Falsework materials delivered to the job site, should be equal to or greater than the grade, or type of material, assumed in the design review. Timber having large shakes, checks or knots, or which are warped or split should not be used at critical locations. Abused timber, although stress graded, may no longer be capable of withstanding the original allowable stress.
 - (3) Rough sawn timbers should be measured to determine their actual dimensions. Unlike surfaced/finished material, the dimensions of rough-cut timber are not uniform from piece to piece. The variation may be appreciable, particularly in the larger sizes commonly used for falsework posts and stringers. If actual dimensions are smaller than the dimension assumed in design, the member may not be capable of carrying the imposed load without overstress. Therefore, undersized material should not be incorporated into the falsework, unless the design is reevaluated using smaller dimensions.
 - (ii) Structural Steel
 - (1) Used beams, particularly beams salvaged from a previous commercial use, should be examined carefully for loss of section due to welding, rivet or bolt holes, deformation or web openings which may adversely affect the ability of the beam to safely carry the load imposed by the falsework design.
 - (2) Welded splices should be inspected visually for obvious defects. Radiographic inspection or other methods of nondestructive testing will not be required as a means of

determining the quality of the splices unless the Project Manager has reason to believe the welds are defective.

(iii) Manufactured Products

- (1) Manufacturer's ratings are based on the use of new material or used material in good condition. The determination as to whether a manufactured product is in good condition is highly subjective and requires experience and judgment.
- (2) When manufactured assemblies are used in falsework, they shall be shown on the falsework plans along with their identification number. The actual assembly shall be clearly and permanently marked with the identification number.
- (3) Identification numbers will allow field inspectors to verify the capacity and proper application of various devices.
- (4) Identification by the contractor applies not only to jacks, beam hangers, overhang brackets, and similar devices, but to all vertical steel shoring systems as well.
- (5) Manufactured products such as tubular steel shoring and steel overhang brackets are particularly vulnerable to damage by continual reuse. Fabricated units in which individual members are bent, twisted, or broken will have a substantial reduction in load carrying capacity. Steel shoring materials should be examined carefully prior to use. Shoring components should not be used if they are heavily rusted, bent, dented, or have broken/damaged welds or other defects. Connections, in particular, should be examined for evidence of cracked or broken welds. Miscellaneous components such as screw jack extensions, clamps, and adjusting pins should be inspected as well.
- (6) Proprietary scaffolding must be used as intended and not subjected to additional stresses or conditions for which it was not originally designed and tested.

5 Cable Bracing

- a. Cable bracing systems must be carefully inspected to ensure that field installation conforms to details shown on the falsework drawings. This is particularly important with respect to the location and method of cable attachment to any falsework.
- b. Prior to installation, each cable should be inspected to verify that the type, size, and condition (new or used) are consistent with design assumptions. Used cable should be inspected for strength-reducing flaws. Use of obviously worn, frayed, kinked, or corroded cable should not be permitted.
- c. Particular attention should be paid to cable clamp fasteners. Improperly installed clamps will reduce the safe working load by as much as 90 percent. Also, the omission of the thimble in a loop connection will reduce the safe working load by approximately 50 percent. After

installation, clamps should be inspected periodically and tightened as necessary to ensure their effectiveness.

- d. A cable clamp has two parts - the "U-Bolt" and the "Saddle." Also a cable has two parts, the wrapped non-continuous end (dead end) and the continuous portion which supports the load (live side). Always put the cable clamp's "saddle" on the live side and the "U-bolt" over the "dead end."

6. Falsework

- a. High quality work, particularly in such details as wedges, fasteners, bracing, friction collars, jack extensions, etc., is critical to the proper performance of falsework. Accordingly, construction details should receive close attention from the project inspector.

- (i) Timber Construction. The following checklist is included as a guide to points which require special consideration:

- (1) Diagonal bracing, including connections, must conform to details shown on the falsework drawings.
 - (2) Diagonal bracing should be inspected after any falsework has been adjusted to grade. Connections must be securely fastened to ensure their effectiveness in resisting horizontal forces. Bolted connections may need retightening.
 - (3) Timber posts may be wedged at either the top or bottom for grade adjustments, but not at both locations. Large posts may require two or more sets of wedges (side by side) to reduce compression stresses perpendicular to the grain.
 - (4) Blocking and wedging should be kept to a minimum. It is poor workmanship to extend a short post by piling up blocks and wedges. This practice should not be permitted.
 - (5) Particular attention should be given to falsework bents where grade adjustment is provided at the bottom of the posts. Differential grade adjustment of posts within a particular bent may induce undesirable stresses in the diagonal bracing.
 - (6) Splicing of wood posts will not be allowed unless shown on approved falsework plans.
 - (7) The ends of spliced posts must be cut square. The need for a post splice should have been anticipated by the contractor and the splice detail shown on falsework drawings. If this is not the case, the contractor must submit a detail for approval.
 - (8) Posts must be plumb and centered over the falsework pad or corbel.
 - (9) Abutting edges of soffit plywood should be set parallel to the joists and continuously supported on a common joist.

- (10) A sufficient number of telltales must be installed to accurately determine the amount of joint take-up and settlement. Telltales should be attached to the joists as close as possible to the supporting post or bent.
- (11) Full bearing must be obtained between all members in contact. Deficiencies in this respect may be improved by feather wedging. If the joint requires more than a single shim or wedge, extra care should be taken to ensure that full bearing is obtained.

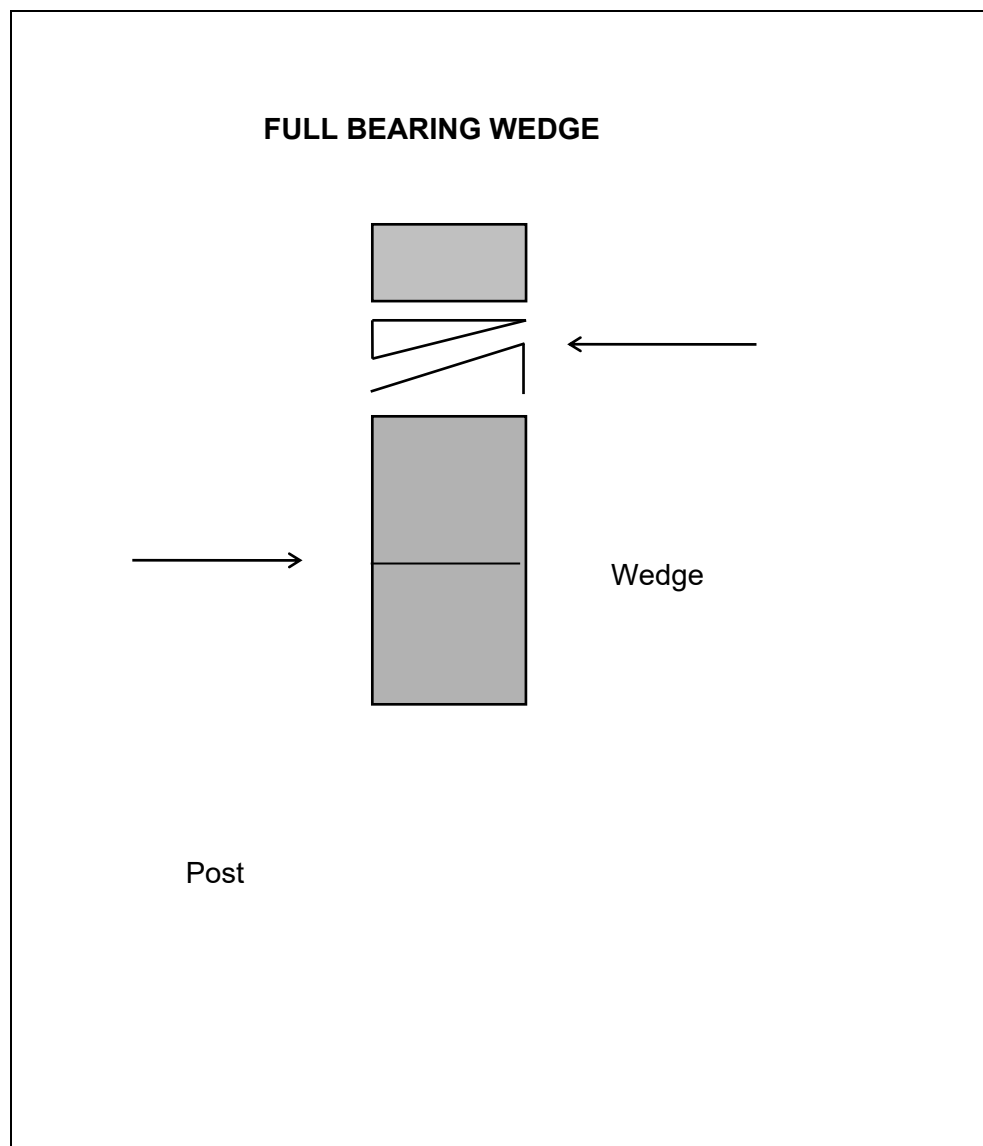

When using wedges, it is a good practice to use wedges inserted from both sides rather than deeply setting a single wedge. Using only one wedge increases the twisting effect on the member.

- When using wedges, it is good practice to install them parallel to and with the flat (non-tapered) side against the main member. This improves

contact with the main member and decreases the chance of a wedge "backing out" from vibration.

- Nail or clamp the wedge in place after installation.
 - (ii) Steel Shoring (Scaffolding). This checklist may be used as a guide by inspectors when inspecting falsework constructed of steel shoring.
 - (1) Shoring components should be inspected prior to erection. Any component that is heavily rusted, bent dented or re-welded, or which is otherwise defective, should be brought to the contractor and project managers attention. Fabricated units having individual members that are bent twisted, broken, or where welded connections are cracked or show evidence of re-welding should be brought to the contractor and Project Manager's attention.
 - (2) A base plate, shore head, or screw jack extension device should be used at the top and bottom of all vertical components.
 - (3) All base plates, shore heads, and extension devices must be in firm contact with the footing at the bottom and the cap or stringer at the top.
 - (4) Shoring components should fit together evenly, without any gap between the upper end of one unit and the lower end of the other unit. Any component which cannot be brought into proper contact with the component it is intended to fit, should not be used.
 - (5) Shore heads, extension devices, and similar components must be axially loaded. Eccentric loads are not permitted on any shoring component.
 - (6) All locking devices on frames and braces must be in good working order, coupling pins must align the frame or panel legs, and pivoted cross-braces must have the center pivot in place.
 - (7) Shoring should be plumb in both directions. Maximum deviation from true vertical should not exceed 3 inches per 1000 inches
 - (iii) Girder Overhangs
 - (1) Girders should be blocked so that the weight of any deck overhang does not bend the girder, which will ripple the deck.

- (iv) Miscellaneous Falsework Items
 - (1) This checklist covers items that may be used in either type of support system.
 - (a) New high strength bolts shall be used on any item that requires bolts to be torqued.
 - (b) Friction collar bolts and concrete anchors should be torqued initially and checked again just prior to concrete placement.
 - (c) Naturally cambered stringers (rolled beams) should be placed with the crown turned upward.
 - (d) Jacks should be plumb and not overextended.
- (v) Falsework Adjacent to Traffic
 - (1) If it occurs, the Construction Division should be notified.
- (vi) Falsework Field Changes
 - (1) If supplemental calculations are necessary to verify compliance with contract requirements, the change will be considered substantial. In this case, the proposed change must be submitted for review and approval in the same manner as the original drawings.
 - (2) The following are examples of changes considered substantial and must be shown on revised falsework drawings, regardless of other considerations:
 - (a) A change in size or spacing of any primary load-carrying member.
 - (b) A change in method of providing lateral or longitudinal stability.
 - (c) Any change, however minor, which affects the falsework to be constructed over or adjacent to a traffic opening or railroad.
 - (d) A revised concrete placing sequence, if it significantly affects the stresses in load-carrying members.
 - (e) When revised drawings are required, they must be submitted for review in the same manner as the original falsework drawings. The Department does not approve falsework! Time shall be allowed for review of revised falsework drawings. Typically this is the same as required for the original submittal.
 - (f) The PM should be alert to and document any field changes to falsework plans.

(vii) Falsework Inspection During Concrete Placement

- (1) As concrete is being placed, the falsework should be inspected at frequent intervals. In particular, look for the following indications of potential failure:
 - (a) Excessive compression at the tops and bottoms of posts and under the ends of stringers.
 - (b) Pulling of nails in lateral bracing.
 - (c) Movement or deflection of braces.
 - (d) Excessive deflection of stringers.
 - (e) Tilting or rotating of joists or stringers.
 - (f) Excessive settlement of tell-tales.
 - (g) Posts or towers that are moving out of plumb.
 - (h) Sounds of falling concrete or breaking timbers.
 - (i) If any member deflects unduly or shows evidence of distress, such as splintering on the bottom of stringers, crushing of joints or wedges, etc., placement work in the affected area should be stopped immediately and the falsework strengthened by addition of members, installation of supplementary supports, or some other means.
 - (j) Settlement of the falsework should be limited to a maximum of $\frac{3}{8}$ inch (10 mm) deviation from the anticipated settlement (as indicated by the falsework designer). Should actual settlement exceed the anticipated settlement by more than the $\frac{3}{8}$ inch (10 mm) allowable, and if it appears that a serious problem is developing, concrete placing should be temporarily discontinued in affected areas until the contractor provides satisfactory corrective measures. Concrete placing should not be resumed until the Project Manager is satisfied that further settlement will not occur.
 - (k) If it is apparent that satisfactory corrective measures cannot be provided prior to initial setting of the concrete, the Project Manager shall stop placing of concrete and contact the Construction Division.
 - (l) One important and often overlooked point is the danger of curing water softening the falsework foundation. Some means should be provided to prevent curing water from reaching and soaking the foundation material beneath the falsework bearing pads.

- (m) The contractor should provide the drainage for any water that accumulates in box-girder cells. Such accumulated water could easily overstress the falsework.
- (viii) Falsework and Centering
- (1) It is the contractor's responsibility to provide form work adequate to support the dead load of the fresh concrete. However, the inspector shall consult with the contractor and the Project Manager concerning any form work which they have reason to believe is inadequate to support the load capacity. In calculating the strength of centering, a mass of 150 lb/ft³ (2400 kg/m³) shall be assumed for fresh concrete.
 - (2) All falsework shall be rigidly braced and cross braced. Timber piling shall be free from defects with at least a 7 inch (175 mm) butt and a 5 inch (125 mm) tip, measured under the bark. The contractor shall provide jacks or suitable wedges to take up any settlement in the form work during the placing of the concrete. When setting grades for falsework or structure forms, allow 1/16 inch (1.5 mm) settlement or "take-up" for each lap in the falsework timbers.
 - (3) Build falsework for slab bridges with 1/8 inch camber for each 10' of span (or as indicated in the plans). Deflection after forms are removed should bring deck back to the proper elevation.
 - (4) Settlement caused by the concrete loads may be checked as placing of the concrete progresses by means of vertical "telltales" fastened to the bottom of the floor form. When this settlement has reached the amount allowed for "take-up" in the falsework timbers, any further settlement should be prevented by means of the wedges or jacks previously noted. Any adjustments that have to be made must be completed before the concrete has taken its initial set. If adjustments are made after the concrete has set, the concrete may be damaged irreparably. (In general, if falsework settles more than 1/2 inch, the PM must investigate and determine the damage.)
- (ix) Removal of Falsework (SSHC 704.03 paragraph 7)
- (1) Specifications and applicable special provisions, contain specific criteria which must be met before falsework may be removed. Project Managers and inspectors should review these sections prior to falsework removal operations.
 - (2) The Project Manager should discuss falsework removal methods and procedures at the preconstruction and/or

prepour meeting. The need to provide for employee and public safety is of particular concern.

- (3) In general, all elements of the falsework bracing system must remain in place for the specified time period or until concrete attains the specific strength. In the case of cast-in-place, post tensioned construction, falsework elements must not be removed until stressing is completed.

7. Forms

- a. The inspector shall check the lines, grades and dimensions on all structural form work before allowing the contractor to place concrete. On walls and columns this is best done as the form work progresses.
- b. Forms shall be made of wood, metal or other approved materials. The forms shall be substantial, unyielding and mortar tight. All forms for exterior exposed surfaces, except those locations requiring a specific texture finish as listed in *SSHC Subsection 704.03* shall be lined with pressed wood, plywood or other approved materials used in the largest practicable panels. Forms shall be coated with a colorless oil to prevent sticking to the concrete. The forms should be oiled before placing the reinforcing steel to avoid splattering of oil on the steel. Forms for walls and columns, or wherever else required, may be constructed with the bottom board removable for cleaning out wood chips, dirt, etc., before placing the concrete. Metal tie rods or anchors within the forms shall be constructed so as to permit their removal to a depth of 1/2 inch below the surface of the finished concrete. All tie rod and tie-wire holes shall be filled with cement mortar as soon as possible to insure proper bond with the structure concrete.
- c. Pier columns may be constructed using a laminated fiber form which is moisture resistant and seamless. These forms must be capable of withstanding the hydraulic pressure of fresh concrete. Any questions concerning the acceptability of a proposed fiber form should be referred to the Structures and Grading Engineer in the Construction Division through the District Construction Engineer.
- d. Tolerances (*AASHTO LRFD Bridge Construction Manual C 3.3.2*)
 - (1) Departure from established alignment.....1.0 inch
 - (2) Departure from established grades.....1.0 inch
 - (3) Variation from plumb or the specified batter in the lines and surface of columns, piers, and walls:
 - Exposed, in 10 ft.....0.5 inch
 - Backfilled, in 10 ft.....1.0 inch
 - (4) Variations from the level of the grades indicated on the drawings in slabs, beams, horizontal grooves, and railings:
 - Exposed, in 10 ft.....0.5 inch
 - Backfilled, in 10 ft.....1.0 inch
 - (5) Variation in cross-sectional dimensions of columns, piers, slabs, walls, beams, and similar parts
 - Minus.....0.25 inch

- Plus.....0.5 inch
 - (6) Variation in thickness of bridge slabs
 - Minus.....0.125 inch
 - Plus.....0.25 inch
 - (7) Variation in the sizes and locations of the slab and wall Openings.....0.5 inch
8. Removal of Forms and Falsework
- a. Specific requirements concerning the time limitations for form removal are listed in *SSHC Subsection 704.03*. Proper inspection includes both the monitoring of this time, concrete strength, and the method of removing forms. Stresses in concrete due to its own weight must be introduced slowly and carefully during form removal operations to prevent concrete failures. For instance, the removing of falsework from under a cantilevered element, must begin at the point furthest from the support and proceed toward the support. In removing the falsework from under a structure that is continuous over its supports, removal should begin near the areas of maximum dead load positive moment (typically the middle of the span) and proceed in both directions towards the supports. In general, all falsework should be removed before placing any surcharge, such as sidewalks and railings, on the superstructures.
 - b. The requirements listed in the Specifications are based on sound engineering principals and the structures inspector should be thoroughly familiar with and rigidly enforce these requirements.
9. Use of Insulated Forms for Protection
- a. Commercial insulation may be used for protecting concrete during cold weather, or when the contract documents require controlling the heat of hydration. This technique is the contractor's option and could be used in lieu of housing and heating. The contractor must furnish housing and heating and/or insulation of sufficient quality and thickness to maintain concrete at a temperature of not less than 50°F (10°C) for the first 72 hours after placing, and above 40°F (5°C) for the next 48 hours.
10. Placing Concrete
- a. Concrete shall be proportioned, mixed and handled in accordance with the requirements of SSHC Section 1002. The inspector should also refer to the Materials and Research Standard Methods of Tests Manual, sampling and field testing the materials necessary for the production of concrete. The contractor shall organize the work so that the maximum interval between batches shall not exceed 30 minutes.
 - b. Concrete should not be placed in footings, columns, etc., until all pile driving within a radius of 25 feet has been completed. If concrete pours must be made within this area prior to the completion of pile driving, such concrete shall set at least three days before further driving is permitted within this radius. Concrete shall not be placed without special permission in steel pile shells for cast-in-place concrete piles for each bent, pier, or abutment until all the shells for that bent pier or abutment have been driven (SSHC Section 703).

- c. When depositing concrete in the forms, segregation must be avoided. The mass of concrete should be generally free of surface cavities resulting from the trapping of air and water along the forms. Careful spading of concrete along vertical forms and tapping of the forms will usually release the air and water bubbles. Forms which are not mortar tight will leak cement paste and result in "sand streaking." Forms should be mortar tight to the maximum extent possible. Chutes shall be of metal or metal lined and of sufficient number to preclude the necessity of shifting the chutes. If necessary, the contractor shall leave holes in the forms for the entry of the chutes or pipes. Concrete must be deposited within 6 ft horizontally of the place of its final location. Concrete shall not be dropped vertically more than 5 feet (1.5 m). Concrete in walls, footings, columns, etc., shall be placed in continuous horizontal layers not more than 18 inches (450 mm) thick and vibrated to a monolithic mass. Do not allow dried concrete to collect on forms or reinforcing bars where it will fall into the work.
 - d. See Section Materials Sampling Guide for cylinder requirement.
11. Placement Methods (Pumping, Belting, And Crane Bucket) (*SSHC Subsection 704.03*)
- a. Much concern has been expressed about the method of concrete placement because of lost entrained air. Rough handling of plastic concrete during placement has, at times, reduced entrained air to less than 2% not to mention potential segregation problems. While testing at the point of placement "should" identify such problems, varying placement conditions during the pour can affect concrete conditions significantly.
 - b. General conditions which must be avoided (Points to watch for), or at least severely minimized, are explained for each delivery system that follows: If one of the following cannot be avoided, at least be aware of the condition, and be sure to conduct additional testing should any of the conditions present themselves.
 - c. Crane and Bucket
 - (i) In the past it was felt the crane and bucket placement method did not adversely affect concrete. This is now in question when viewed from loss of air and potential segregation. Therefore, this method will now also require testing at the placement location, if practical.
 - (ii) Points-to-Watch For
 - (1) Free fall of unrestrained concrete shall not exceed 5 ft (1.5 m.) Avoid exceeding a 5-ft. free fall by removing a section of form work for intermediate placement or by use of a tremie.
 - (2) Discharge from the bucket must be controllable.
 - (3) Cross section of the drop chute should allow it to be inserted into the form work without interfering with reinforcing steel.

d. Belt Placement

- (i) Belt equipment is typically used to convey concrete to a: (1) lower, (2) horizontal, or (3) somewhat higher level.
- (ii) Points-to-Watch For
 - (1) Keep the number and distance of drops between belts to an absolute minimum. Drops tend to encourage segregation and reduce entrained air.
 - (2) As belt conveyors are removed from the line (i.e., as on deck pours), recheck the "as placed" air content.
 - (3) Be sure all mortar is being removed at the discharge. (No mortar should be on the return belt.)
 - (4) Check discharge for potential segregation problems.
 - (5) In adverse weather (hot and/or windy conditions), long belt runs need to be covered.

e. Pump Placement

- (i) The modern mobile pump with hydraulic placing boom is economical to use in placing both large and small quantities of concrete. These units are used to convey concrete directly from a truck unloading point to the concrete placement area.
- (ii) Points-to-Watch For
 - a. Typically, pumps are initially flushed with a thin water/cement paste mixture to coat the lines. This slurry must be wasted and the lines charged with the project mix before beginning. Observe, and be sure initial pump charge is thoroughly removed from the pipelines.
 - b. Always pump at a constant rate and keep pipelines full of concrete. High air loss can occur when concrete is allowed to free-fall inside pump lines.
 - c. Avoid, if at all possible, having steep angles in the pump pipelines. Steep angles and slow placement rates are probably the worst conditions for minimizing air loss and segregation. If this condition occurs:
 - (1) Attempt to relocate the pumper, thereby minimizing lift angle.
 - (2) If discharge is not maintaining a constant flow with the partial concrete head in the pipe, request the pump operator to place a reducer and short section of hose at the discharge end. The purpose is to avoid free falling concrete from impacting the deck or forms at high velocity.
 - (3) If the above condition is unavoidable, watch and test the discharge frequently for loss in air and potential segregation.

- f. Rule-of-Thumb for Pumping
 - (i) Pump concrete with pipelines as flat as possible (or at least with minimal down angle).
 - (ii) Minimize (or eliminate) free falling concrete in the pipelines. To do this, maintain some amount of concrete head in the pipelines.
 - (iii) Pump concrete through as few elbows and restrictions as possible.
 - (iv) Pump concrete at "some" constant rate.
 - (v) Watch and test the air content frequently, when drop may exceed 5 feet. Take samples of concrete from the bridge deck, do not swing pipeline off the bridge to sample concrete. This will lead to a false air.

- 12. Consolidation of Concrete
 - a. The contractor must establish a pattern for vibrating the concrete and ensure the pattern is followed for the entire pour.
 - b. Consolidation of concrete should be accomplished by the use of a sufficient number of vibrators of a type approved by the Project Manager. The vibrators must be of such an intensity as to visibly affect one-inch slump concrete over a radius of 18 inches (450 mm). The contractor is required to furnish a tachometer for the purpose of checking the speed of the vibrator elements.
 - c. Lateral movement of the concrete by means of a vibrators shall be avoided. Over vibration is harmful and is evidenced by grout appearing in the concrete around the vibrator head. Insert and withdraw the vibrator slowly. It should not come in contact with reinforcing steel which extends into previously placed concrete nor should the vibrator head be placed in concrete which is taking its initial set.

- 13. Reinforcement Bar Cover
 - a. Reinforcement bar cover has contributed to shadow effect. This occurs when reinforcing cage is not rigid or has only a minimum of cover and too much vibration was used. The remedy:
 - (i) Increase bar cover to 2 ½ inches (65 mm) from minimum of 2 inches (50 mm).
 - (ii) Maintain uniformity of bar cover.
 - (iii) Build in rigidity to the reinforcing bar cage by placing diagonal braces as described above.
 - (iv) Reduce slump and do not over vibrate the concrete.
 - (v) Require a dry run on bridge decks to check alignment and uniform spacing between the edge of the strike off and rebar cage.

- b. Shadowing occurs when slip forming a radius because of nonuniform form pressures inside the strike off. The problem manifests as repetitious surface bumps, not depressions as one might think. This problem is inherent with slipforming a radius and is especially noticeable as the radius becomes smaller. In order to minimize shadowing effects, the contractor needs to have finishers work out the bumps by hand.
14. Flowable Fill (*SSHC Section 1003*)
- a. The inspector shall make daily entries in the field book on all concrete placed for each project. Record concrete placement location, all results of sieve analysis tests, all data on test beams made and tested and all quantities placed.
 - b. Flowable fill can be used for the following purposes:
 - (i) Backfilling culverts.
 - (ii) Backfilling culverts constructed under bridges.
 - (iii) Filling void between culvert and culvert liner.
 - (iv) Plugging culverts.
 - c. Free water in the sand pile must be considered as mix water because a mix design uses oven dried sand.
 - d. If the contractor uses crushed limestone for granular backfill, it shall meet the requirements for Granular Backfill. (Refer to *SSHC Section 1033*.)
 - e. Remember flowable fill is a liquid until the water has dissipated. Bulkheads should be strong enough to withstand the hydraulic pressures.
 - f. Under normal conditions, flowable mortar should be set-up sufficiently within 24 to 48 hours for placement of the final lift of either earthfill or special backfill. If "set-up" does not occur or if it seems slow, typically the problem relates directly to drainage of the granular backfill. Often contamination or "dirty" granular backfill is the culprit. Check to be sure it is draining. If not, additional time will help.
15. Concreting in Cold Weather (*SSHC Subsections 704.03 and 1002.02*)
- a. As colder weather approaches each fall, the Department experiences a series of problems connected with concrete construction in cold weather. The first indication of the problem usually shows up as a low test result on a 7 day cylinder. the contractor should be notified of a potential low strength issue. Actual acceptance is based on the 28-day strength.
 - b. Regardless of the temperatures outside, cylinder for the acceptance of structural concrete should be kept between 60 and 80 degrees F (ASTM C31) for the first 48 hours and then moved to a lab. Cylinder not used for acceptance (stripping forms, opening to traffic, etc.) should be kept in approximately the same conditions as the structure itself.
 - c. In some cases, definite information regarding the true condition of the concrete in the structure can only be obtained by coring the material and carrying out a series of special tests.

16. Approach Sections--Bridge Approach Tapers
- a. Shoulder Maintenance - When temporary concrete barrier rails are used on deck repair and overlay jobs, traffic is constricted into a narrower lane. This in turn could cause a rapid deterioration of shoulders at bridge approaches and require the following corrective measures:
 - (i) Ruts developing in earth and granular shoulders should be repaired as necessary with a granular surfacing material. This is extra work order and a change order will be issued for this work.
 - (ii) Ruts and loss of asphaltic cement concrete surfacing on Interstate shoulders should be repaired using an asphalt cement concrete pre-mix, hot mix, or some similar treatment to minimize the development of holes or ruts. A change order may be needed for this work unless there is an ACC contract item for shoulder maintenance and even then it may have to be extended.
 - (iii) When shoulder strengthening was not included as a bid item, but is needed for the project, the change order must consider:
 - (1) Present shoulder construction and experience with shoulder stability in the immediate area.
 - (2) Traffic volumes, percent of trucks, and duration of potential problem.
17. Setting Beams
- a. The following should be used as a guide in conjunction with *SSHC Section 704*:
 - (i) No beams may be set on substructure elements concrete has at least 2,000 psi compressive strength.

704.04 METHOD OF MEASUREMENT

- 1. The cubic yards of concrete for structures of varying sizes are computed from dimensions shown in the plans and placed in tables in the plans. All structures using the same type of concrete are lumped together.

704.05 BASIS OF PAYMENT

705.00 PRECAST/PRESTRESSED CONCRETE STRUCTURAL UNITS

705.01 DESCRIPTION

705.02 MATERIAL REQUIREMENTS

705.03 CONSTRUCTION METHODS

705.04 METHOD OF MEASUREMENT

705.05 BASIS OF PAYMENT

706.00 CONCRETE BRIDGE FLOORS

706.01 DESCRIPTION

SSHHC References:

- Section 706 Concrete Bridge Floors*
- Section 1002 Portland Cement Concrete*
- Section 1010 White Opaque Polyethylene Film and Burlap--Polyethylene Sheeting For Curing Concrete*
- Section 1011 Burlap For Curing Concrete*
- Section 1014 Joint Sealing Filler*
- Section 1015 Preformed Joint Filler*
- Section 1016 Preformed Polychloroprene Elastomeric Joint Seals*
- Section 1033 Aggregates*

Inspection Crew:

- Project Manager
- Placement Inspector

Inspection Equipment:

- Slump Cone
- Air Meter (pressure)
- Cylinder Molds and Lids
- Rod
- Mallet
- Strike Off Bar
- Ruler
- 10 ft (3 m) straightedge
- Anemometer
- Thermometer
- Hygrometer

Placement Procedures:

1. Preplacement check of equipment.
2. Check condition and placement of steel. Enter in SiteManager the date steel was verified.
3. Check Form setting and alignment.
4. Check slab thickness.
5. Check deck for cleanliness
6. Have contractor wet deck forms and grade under approach slabs before concrete placement.
(Note: It's best to place deck and approach slabs at the same time.)
7. Test concrete for air content and make cylinders when mix changes, as a minimum according to [Materials Sampling Guide](#).

8. Watch concrete placement for compliance with specifications.
9. Do not use water as a finishing aid; use an approved chemical finishing aid/evaporation retardant.
10. Check surface with straightedge. Remove depressions and irregularities.
11. Check tining operation.
12. Check cure operation.
13. Make sure a water service and tanks are available to soak burlap.

Construction Critical Area:

1. Take pictures of any pavement under the deck before work begins.
2. Maintain a uniform roll of concrete ahead of the rollers on the paver.
3. The time between loads of concrete.
4. Trucks that segregate concrete or have cement balls must not be used.
5. Avoiding placement when temperatures and wind velocities may cause plastic shrinkage cracking. (SSHC Table 706.01)
6. Vibrate concrete uniformly. Establish good pattern and adjust as necessary.
7. The timing of cure application.

Safety Areas:

NDOT Tests:

1. ASTM C 31 Making and Curing concrete test specimens.
2. ASTM C 143/C 143M Slump of Portland Cement Concrete.
3. ASTM C 172 Sampling of Fresh Concrete.
4. ASTM C 231 Air Content of Freshly Mixed Concrete by the Pressure Method.

706.02 MATERIAL REQUIREMENTS

706.03 CONSTRUCTION METHODS

1. Prepour Meeting
 - a. It is very important to use the prepour meeting to discuss the specifics of placement, establish communication, and resolve potential "sticky" issues prior to placement. Generally it is recommended to discuss:
 - (i) Chain-of-command. Who is in charge for the contractor? Who needs to be notified if material tests do not comply with specifications? Establish prior to placement how test results are reported (i.e., does the Contractor want to be notified verbally, or in writing each time?).
 - (ii) More cement paste could cause more shrinkage cracks and less paste means would lead to fewer cracks.
 - (iii) Material requirements and admixtures needed for the placement (Examples: Single cement source, concrete temperature and methods used to cool the mix, source and amount of any admixtures, specific mixes required for bridge decks, etc.)

- (iv) Procedures for introducing admixtures during mixing operations need to be discussed and formalized. For example: How and where will the air entraining agent be introduced? There is a growing concern that placement location of admixtures is causing significant variability in mixes. The plant monitor must watch and document how admixtures are introduced during mixing.
 - (v) Method and frequency of acceptance testing during any placement. Inform the Contractor what is expected if non-acceptable material is found during placement.
 - (vi) Scheduling, truck availability, placement method, and required placement rates.
 - (vii) Establish an acceptable source of preplacement weather forecasting. Agree on weather parameters which will be used for "go" or "no-go" decisions both "prior to" and during the placement activity.
- b. The placing of concrete will require close monitoring to comply with the specifications. Obtain a weather report to determine predicted air temperature, wind velocity, and relative humidity for the pour day.
- c. The above information should be discussed by the inspector, contractor, and ready mix plant operator before a deck pour. The pour should not be attempted if concrete temperature is predicted at 90F (30°C) or higher and predicted air temperature is above 90°F (30°C).
- d. Adequate Labor Force
- (i) At preplacement meetings talk about and, before starting a placement be sure the contractor has:
 - (1) Proper and adequate materials to protect the placement, including plastic in the event of rain.
 - (2) Adequate numbers of sufficiently skilled laborers available.
 - (3) Proper tools on the job.
 - (4) Arranged for the rate of delivery of concrete to make the placement operation efficient.
 - (ii) 20 ft/hour on girder bridges and 10 ft/hour on slabs should be the minimum placement rate. Any method of delivery to the deck should be checked to see that rate of placement can be such that finishing operations can proceed at a steady pace, with final finishing completed before the concrete starts its initial set.
- e. Curing and protection
- (i) Discuss the curing procedures with the contractor. Burlap needs to be fully saturated before starting the pour.
 - (ii) Sufficient labor needs to be available to place the burlap immediately after the finishing machine.
 - (ii) If rain is a possibility, plastic or other protection method should be on hand and ready to protect the concrete.

2. Deck Shims

- a. A girder shim is defined as the distance measured from top of girder to top of finished slab. There are three different types of bridges which we build that have girder shims. The first type is a steel girder bridge, either a rolled beam section or a plate girder section. The second type is a prestressed girder (NU Girder Section). The third type is a prestressed inverted tee girder. Shim shot shall be taken at the locations indicated on the shim shot sheets provided by the Bridge Designer.
- b. For each type, the definition of the girder shim is the same; girder shim is the distance measured from the top of girder to top of finished slab.
- c. Stages of the Girder Shim Process:
 - (i) The Bridge Division, upon completion of the design, will prepare the shim input forms.
 - (ii) After the project has been let, we send these forms to the Project Manager.

After the girders are erected and prior to forming the deck for the slab, shim shots are required to be taken. These shim shots should be taken at the bearings, field splices, and at 10 ft (3 m) intervals along the length of the girder.
 - (iii) The shim shots are recorded on the input forms and submitted to the Bridge Division
 - (iv) The Bridge Division computes the shims and sends to Project Manager.
- d. The H.I. Elevation needs to be recorded by the inspector at the time the shim shots are taken.
- e. The rod readings at each location are recorded. This information is normally sent by email to the Bridge Division. The Bridge Division will run the calculations which uses the grade of the roadway, crown of roadway, the dead load deflection of the girder, and your rod readings to determine the amount of shim at each location.
- f. The Bridge Division will look at the shims to see if they are too large or too small. The final shim information will be sent to the Project Manager along with solutions to any problems which may have occurred.
- g. The proper girder shims are critical to ensure that construction of the bridge is in accordance with the intended design.

3. Proper vs. Improper Shims
 - a. When you are inspecting a job, a visual inspection of the relationship of the shear connectors to the slab reinforcement will help you determine if something is wrong. Based on the slab thicknesses that we normally use [7.5 inches (190 mm) or 8 inches (205 mm) thick, the length of stud that we normally use [5 inches (125 mm long)] and if the slab is reinforced, the end of the sheer connector should be located somewhere between the top and bottom transverse slab reinforcing steel.
 - b. We specify 1 inch (25 mm) of clearance between the bottom of the slab and the bottom transverse reinforcing steel. A 3/4 inch (20 mm) bar is the largest bar specified. Therefore, knowing that we need 2 inches (50 mm) of penetration for the shear connectors, the top of the shear connector should always be above the transverse bar in the bottom of the slab.
 - c. The Bridge Designer may require additional bars called "Hat Bars" if the shear reinforcement does not extend into the deck sufficiently.
4. Problems and Solutions
 - a. When we have the problem of too large of a shim, there are a couple of things we can do to solve this problem. One solution is to provide some reinforcing bars at each shear connector location that properly extend into the slab. Another solution is to weld a plate onto the top of the shear connectors to gain the proper penetration length.
 - b. Where we have the problem of too small of a shim (top flange extending into the slab) there is only basically one thing you can do. That is to raise the grade of the roadway.
5. Critical Item - Proper Girder Seat Elevations
 - a. The most important thing that our inspectors can do to insure proper shims is to make sure that the girder seats are poured to the proper elevations. If the girder seat elevations are wrong, you can almost be sure that you will have problems with your shims. If your girder seats are correct, more than likely your shims will also be correct.
6. Critical Item - To Ensure Proper Shim
 - a. Steel girders must be set on substructure by following the blocking diagram shown on the plans.

Example Shim Sheet:

Location Span		Location Station @ CL Bridge	SHIM CALCULATION SUI						
			Girder A						
			Location Station @ CL Girder	Left Edge of Flange			Right Edge of Flange		
Survey Rod Reading	Top of Girder Before Slab Placement	DECK THICKNESS FOR SHIMS		Survey Rod Reading	Top of Girder Before Slab Placement	DECK THICKNESS FOR SHIMS			
Span No. 1 - 60'-0"	End of Girder - Top Flange	1021+23.00	1021+23.00	3.83	2390.72	0.76			
	10'-0"	1021+33.00	1021+33.00	3.76	2390.79	0.67	3.75	2390.80	0.74
	20'-0"	1021+43.00	1021+43.00	3.74	2390.81	0.67	3.73	2390.82	0.74
	30'-0"	1021+53.00	1021+53.00	3.73	2390.82	0.66	3.73	2390.82	0.74
	40'-0"	1021+63.00	1021+63.00	3.78	2390.77	0.70	3.77	2390.78	0.77
	50'-0"	1021+73.00	1021+73.00	3.86	2390.69	0.76	3.84	2390.71	0.82
	End of Girder - Top Flange	1021+83.17	1021+83.17	3.90	2390.65	0.80			
Span No. 2 - 90'-0"	End of Girder - Top Flange	1021+83.83	1021+83.83	3.91	2390.64	0.81			
	10'-0"	1021+93.83	1021+93.83	3.82	2390.73	0.73	3.81	2390.74	0.80
	20'-0"	1022+03.83	1022+03.83	3.75	2390.80	0.68	3.74	2390.81	0.75
	30'-0"	1022+13.83	1022+13.83	3.74	2390.81	0.68	3.72	2390.83	0.74
	40'-0"	1022+23.83	1022+23.83	3.72	2390.83	0.64	3.70	2390.85	0.70
	50'-0"	1022+33.83	1022+33.83	3.79	2390.76	0.67	3.76	2390.79	0.72
	60'-0"	1022+43.83	1022+43.83	3.87	2390.68	0.69	3.84	2390.71	0.74
	70'-0"	1022+53.83	1022+53.83	3.96	2390.59	0.70	3.94	2390.61	0.76
	80'-0"	1022+63.83	1022+63.83	4.13	2390.42	0.77	4.10	2390.45	0.82
End of Girder - Top Flange	1022+73.17	1022+73.17	4.24	2390.31	0.80				
Span No. 3 - 60'-0"	End of Girder - Top Flange	1022+73.83	1022+73.83	4.30	2390.25	0.85			
	10'-0"	1022+83.83	1022+83.83	4.31	2390.24	0.78	4.30	2390.25	0.85
	20'-0"	1022+93.83	1022+93.83	4.32	2390.23	0.74	4.29	2390.26	0.79
	30'-0"	1023+03.83	1023+03.83	4.36	2390.19	0.71	4.34	2390.21	0.77
	40'-0"	1023+13.83	1023+13.83	4.42	2390.13	0.70	4.40	2390.15	0.76
	50'-0"	1023+23.83	1023+23.83	4.51	2390.04	0.71	4.52	2390.03	0.80
	End of Girder - Top Flange	1023+34.00	1023+34.00	4.65	2389.90	0.79			

7. Composite Girders

a. There are two methods of designing girders. One method is a non-composite design and the other method is a composite design. The non-composite design is basically the slab sitting on top of the girders. By providing shear connectors on the top of the top flange, we can tie the slab to the girders into what we call a composite section. On prestressed girders, the stirrups extending out of the girder into the slab provide the composite action. The composite section produces a more economical design. The Bridge Division designs the girders as a composite section.

b. AASHTO Specifications

- (1) In order for this composite action to actually take place, it is critical that these shear connectors extend into the slab the proper amount. For steel girders, AASHTO specifications require that the shear connectors penetrate at least 2 inches (50 mm) above the bottom of the slab.
- (2) The AASHTO specifications also state that the clear depth of concrete over the tops of the shear connectors for steel girders shall not be less than 2 inches (50 mm). So this gives the Bridge

Division a range for the location for the top of the shear connectors.

8. Environmental Conditions

a. Deck Concrete Temperature

(i) Subsection 706.03 identifies requirements for placing and curing concrete bridge floors. Of importance for this section are:

- (1) Plastic concrete, when placed, shall not exceed 90°F (30°C).
- (2) If the forecast high outside air temperature for the day is predicted to be above 80°F (26°C) the contractor should cast the deck starting at 5:00pm.
- (3) Decks should be cast after the afternoon high temperature is reached. (In summer, this can be as late as 7:00 p.m.) Protection of the aggregates from the sun is also helpful.

(ii) There are several ways concrete temperatures may be kept within specifications. They are:

- (1) Scheduling placements during cooler times of the day.
- (2) Wetting the aggregate stockpiles.
- (3) Covering/shading the aggregate stockpiles.
- (4) Maintaining a supply of Portland cement on hand to preclude getting hot material from the supplier.
- (5) Chilling the mixing water is one of the most effective ways to lower mix temperatures.
- (6) Shaved ice can be used, however, the ready mix operator must submit a proposal for this to the Project Manager for review by the Construction Division.

NOTE:

- No payment will be made for methods taken to keep concrete temperatures within specifications.
- If pour has to be delayed because of temperature, and pouring is the controlling operation, no working days will be charged.
- Location of permissible headers should be discussed with the contractor during the pour, it appears the temperature may exceed 90°F (30°C).

(iii) Working time of concrete varies with the temperature of concrete, and concrete temperature varies with the temperature of different materials used in the mix. In order to determine the dosage rate of retarder, an estimate of the mix temperature must be made. The following are suggested estimating methods:

- (1) The temperature of concrete from previous placements could be taken.

- (2) If a ready mix producer is placing concrete the day before a deck placement, this concrete could be checked for concrete temperature.
 - b. Regardless of the method used, make the best estimate of what the concrete temperature will be during the warmest part of the day. Remember, concrete shall not be placed in new decks if the concrete temperature is above 90°F (30°C).
9. Placement Considerations
- a. If there is any doubt about the concrete temperature exceeding 90°F (30°C), the contractor needs to identify measures which will be implemented to keep mix temperatures within specifications. If the contractor is not prepared to maintain a mix temperature below specifications, the pour should be postponed.
 - b. General - The wind velocity temperature relationships stated in the specifications (Table 706.01 in SSHC) should be enforced to avoid loss of water from the concrete surface faster than it can be replaced by normal bleeding and to avoid the resultant formation of plastic shrinkage cracks. Anemometers and thermometers must be available on site to measure wind velocity and temperature.
 - c. Concrete in bridge floors shall be placed uniformly on both sides of the centerline and shall be placed continuously between specified joints. The sequence of placing shall be in accordance with the pouring diagram shown in the plans. If no pouring diagram is shown in the plans, concrete shall be placed continuously from one end of the bridge to the other.
 - d. Wet the deck forms and approach slab grade before placing the concrete. Concrete shall be adequately vibrated to encase the lower bars of the reinforcing mat where these are near the deck form.
 - e. Special attention shall be given to finishing the riding surface on the bridge floors. *SSHC* Subsections 706.03, and 711.03 explain concrete bridge floor finish.
 - f. The specification require the contractor to use a self-propelled bridge finishing machine for bridge deck pours. The specification does allow for hand finishing of small or irregular areas.
 - g. Method of Finish - When the hand method is employed (small or irregular areas), the concrete surface shall be struck off with a strike board which conforms to the cross section shown in the plans. If this is pulled by hand, care shall be taken not to displace the reinforcing steel by the workmen doing the pulling. A small winch anchored to a girder outside of the day's pour will pull the strike off at a slow, uniform rate, giving a truer surface with no displacement of the reinforcing steel. The strike board shall be operated with a combined longitudinal and transverse motion, always carrying a small roll of concrete in front of the cutting edge. The strike off shall be pulled a sufficient number of times to properly distribute the concrete. A longitudinal float generally is required and is described in *SSHC Section 704*. The longitudinal float shall be lapped 1/2 its length when moved to a new position and shall be operated across the surface a sufficient number of times to produce a uniform, smooth riding surface.

Occasionally during the finishing operation, conditions may require the use of the long-handled transverse float, which require extreme care in its use to preserve the desired cross-section and a smooth riding surface.

- h. When hand finishing methods are used, the floor surface shall be tested for trueness with a straightedge 10 foot (3 m). The bridge contractor is required to furnish a 10 ft master straightedge for use in trueing and checking the working straightedges.
- i. A burlap drag is required and this operation should be performed as soon as the surface will support the drag. A tined surface may also be required by the specifications if there is no longitudinal grooving in the plans.
- j. Templates used to support the strike off should be in short sections [(10 to 14 ft) (3 m to 4 m)] so they may be removed as the finishing operation advances, allowing the final floating and surface testing to take place, and the wet burlap to be applied immediately.
- k. When mechanical self-propelled finishing machines are used, they shall be capable of obtaining a finish equal to or better than that obtained by the hand method. The screeds of the finishing machine should be set to the exact cross section shown in the plans. Elevation shots will be required for the setting of the riding rails. The usual procedure is to give a fill to grade at the locations where girder shots were taken. The contractor will then set the rail to the correct height to accommodate the machine. An "eyeball" check of the rail for smoothness should always be made. On girder bridges the rail will follow a line that should be smooth after the girders have deflected from the dead load. Correct elevations of the rail can be checked by measuring the distance from the screed to the formwork which should give the correct thickness of slab.
- l. Careful attention should be given to the depth of cover over the top steel. With the extensive use of salt, the service life of the steel is reduced if the concrete cover is less than that shown in the plan. (The finishing machine must be dry run to check the minimum clearance of the reinforcing steel and to check the grade of the expansion devices.)
- m. If the finishing machine is used when there is a transition between regular crown and full superelevation, a system should be worked out well in advance of pouring to insure that the screed can be changed rapidly and correctly at intermediate points of the transition. This is important in order that there are no long delays caused by screed adjustments while pouring the transition.
- n. Retarders – Retarders shall be used to delay the setting time of the bridge floor concrete. If the temperature is 60°F (15°C) and rising, retarders must be used. A good goal is to be finishing at the next pier before the concrete is setting-up at the previous pier.
- o. When a retarder is required the rate of placing concrete for any positive moment section will be within two-thirds of the initial setting up time of the retarded concrete after the previous negative moment section has been poured. For example, if the initial set takes place in 6 hours, the pouring of a positive moment section must be completed within 4 hours after the completion of the previous negative moment section. This same

procedure should be required regardless of whether or not retarders are used.

- p. All ready mix plants shall be NRMCA (National Ready Mixed Concrete Association) certified.
10. Use of Finishing Machine (*SSHC Subsections 711.03*)
- a. The finishing machine shall be approved before use. Care must be taken to adjust the screeds to proper crown. Support rails must extend beyond the bridge at both ends at proper grade and sufficient distance to accommodate the machine. This permits finishing to begin promptly at the start of the run and also permits the required straight edging to proceed on schedule at the end of the run.
11. Straight edging
- a. Following the hand finishing, straight edging should be completed to check for longitudinal smoothness. Straight edges, 10 ft (3 m) in length, need to be operated parallel to centerline of roadway. Each pass should overlap the previous one by a half-length. If bull-floating (mopping) is needed to close up the surface, it should always be followed by straight edging.
 - b. Straight edging is not required with finishing machines as it delays the placement of wet burlap.
12. Tining (Transverse Grooves)
- a. If no pay item for grooving is included on the plans and the bridge is not going to receive an asphalt overlay, the bridge deck will be tined following finishing
 - (i) Tine bridge decks with a rake. Corrugated bull-floats are not allowed.
 - (ii) After straight edging, and as soon as practical following finishing, the entire traffic surface, except areas within approximately 2 ft (600 mm) from the curbs, shall be given a suitable tining with corrugated tining rake.
 - (iii) Tine all bridge decks where posted speed limit will be 40 mph or greater, except for county road bridges 100 feet (30 m) or less in length that have gravel approaches and no plans exist for future hard surfacing.
 - (iv) On bridge decks, stop the tining 2 ft (600 mm) from the face of the bridge curb.
 - (v) Do not overlap the grooving.
13. Curing
- a. The Section 706 of the SSHC defines how to cure the deck.
 - b. The surface must be covered with wet burlap within 20 minutes. (Slight surface marring and removal of tining is acceptable.) Burlap must be wet before placing. In hot dry weather, it is better to be a little early than late with burlap cover.

- c. Since shrinkage cracks are due to rapid loss of mix water before the concrete has attained adequate strength, it is imperative that curing protection be initiated before much evaporation can occur. .
 - d. The curing method requires "wet" burlap cure for 10 days.
14. Ways to Avoid Deck Cracks
- a. Verify falsework is stable.
 - (i) Temporary piles need to have significant bearing – practical refusal is best.
 - (ii) Wood crush needs to be minimized. Avoid gaps between layers of timbers – be careful to shim the entire length of support timbers.
 - b. Avoid unnecessary vibrations.
 - (i) Use shooflys where possible to keep traffic away from the bridge.
 - (ii) Do not rest falsework on active bridge during phased construction unless there is no other alternative.
 - (iii) However, when it comes to intentional consolidation – the contractor should be very careful to establish a fix pattern for vibration and make sure it is achieved along the entire length of the deck and approaches.
 - (iv) When casting deck on Phased Construction under traffic make sure potholes in the driving lanes are filled.
 - c. Check the temperature of the concrete as it arrives on site. It shall not be greater than 90°F.
 - d. Low slump measurements are a good indicator that mix is too dry especially on hot days. Also, with a low slump, it will be hard to get the mix around and in between rebars and tining with the tining rake is much more difficult.
 - e. Consider skewing paver if skew of bridge exceeds 20 degrees.
 - f. Cover the concrete with saturated wet burlap 20minutes after the concrete is finished.
 - g. If the outside air temperature is predicted to be above 80°F (26°C) then start casting the deck in the evening and finish before dawn.
 - h. Check the outside air temperature during casting. It shall be less than 90°F for wind speeds up to 10 mph. See table 706.01 for higher wind speeds.
15. Seal Bridge Deck Cracks
- a. Bridge deck cracks should be sealed before de-icing salt is ever applied on or near the deck.
 - b. High molecular weight methacrylate is the only bridge deck crack sealer on the APL and are squeegeed into cracks (or as directed by the engineer).

16. Floor Drains
 - a. Check floor drain locations against floor grades to be sure deck surface will drain. Adjustments of drain height may be advantageous on every flat grade surface. Also, at this time, study the discharge area from the floor drain for potential damage to features under the structure such as shoulders, railroads, or berm slopes. Major problems foreseen should be brought to the attention of the Construction Division.
17. Curing Concrete
 - a. The structure inspector should give careful attention to the curing, since proper curing is essential to good quality concrete.
 - b. Applying wet burlap as soon as possible is essential – limited damage of tining is acceptable. The wet burlap should always be on the deck by 20 minutes after that portion is finished.
18. Simultaneous Casting of Deck and Approach Slabs
 - a. Casting the approach slabs and the deck simultaneously creates a smoother transition and ride. However, to avoid maintenance and to preserve the integrity of the deck and the approach slabs, a metal bond breaker should be placed over the abutment across the entire width and depth of the deck. This will ensure that a random crack does not occur before the joint can be tooled. At the grade beam, the joint is usually blocked out with extruded polystyrene (Styrofoam).
 - b. The rail that the finishing machine rides on must be uniformly rigid. Unfortunately, where the rail passes over the grade beam and abutment, the rail is frequently more rigid than either side of these substructures. This can cause a dip either side of the abutment and the grade beam, which can result in a “bump” over the abutment, and grade beam.
 - c. Another problem can result when the deck overhangs the outside girder. Typically, the deck forms are supported by outrigger jacks braced against the outside girder. The weight of the concrete and the finishing machine can momentarily bend the outside girder as the placing operation progresses. Temporary construction braces (usually wood blocks) between all girders can prevent girder movement.
19. Surface Checking (Not in Spec)
 - a. A 10 foot (3 m) straightedge surface check shall be conducted on all bridges and deck overlays not covered by the Smoothness Specification (Section 733), See section 706.03. Surface areas inaccessible to profilograph shall also be checked.
20. Test Procedure for Smoothness
 - a. Section of 733 of the SSHC covers “Bridge Deck and Approach Slab Smoothness”. This spec deals with the method of testing for smoothness and the method for correcting surfaces outside of the smoothness limits. The contractor is responsible for scheduling the testing, which will be performed by Materials and Research Division personnel. The contractor must give the Project Manager seven day notice prior to the date he requests that testing be done. The Project Manager shall contact the

Materials and Research Division Smoothness and Coring Section and arrange for testing on the requested date. Evaluation

- b. Materials and Research Division will furnish a profile index to the contractor within 72 hours of the completion of the tests.

21. Smoothness of Bridge Decks

- a. Checklist - The following items should be checked and procedures followed prior to, during, and after the deck pour or overlay is placed to insure a smooth riding deck surface:

- (i) Guide rails are used to support and guide the finishing machine. Check for rail deflection during passage of finish machine. Any vertical or horizontal movement could compromise smoothness and rideability. Request that the contractor readjust anchor legs and/or tie-downs.

- (ii) Check that all propulsion and control equipment are fully operational prior to placing concrete. The contractor shall traverse the finishing machine over the entire length of section to be placed. This not only serves to verify that equipment and control systems are functioning properly, but also provides a check to assure that screeds are adjusted for proper crown and height above existing surface (overlays).

- (iii) Ensure that adequate number of vehicles are available at the work site to transport mix from mixer to the placement area at a volume necessary to provide a uniform rate of forward progress. Any equipment working on the deck should be checked for oil and hydraulic fluid leaks.

- (iv) Contractor must provide sufficient, trained personnel to carry out the various phases of deck placement. Timeliness is of utmost importance during placement operations. Be sure specialized crafts, such as finishers, are adequately represented and preferably have only one task during the placement.

- (v) Check concrete for smoothness with the 10 ft (3 m) straightedge. The straightedge should be placed on the surface from a vertical position, not pushed over the surface. Irregularities can be detected by comparing deck surface with a straightedge. Irregularities noted at this time should be corrected.

- b. Surface Correction

- (i) Corrective work shall be done in the presence of the Engineer with a diamond bladed grinder at least one meter wide. Grinding residue must be controlled. After the deck is ground, a second test will be made to determine if the deck now meets the smoothness requirements. This second test will also be performed by Materials and Research personnel and it is anticipated they will be on-site at the time of grinding, in order that they may perform the retest while the grinding equipment is on-site.

- c. Acceptance
 - (i) Materials and Research personnel will notify the Project Manager whether or not the corrective work has resulted in an acceptable deck surface. If grinding cannot correct the surface profile, the Specification requires removal and an overlay with high-density low slump concrete, although this is no longer done. Contact Construction Division for additional guidance.
 - (ii) Troubles and expense of this sort could virtually be eliminated by careful and detailed inspection by project personnel during construction.
- d. Missed Texturing
 - (i) There will be times, due to various reasons, when texturing will have to be omitted from a pour. One such event could be when inclement weather catches a pour and covering prevents texturing. Obviously this condition is **NOT** desirable.
 - (ii) After full cure time has expired, grind in the required texture.

22. Temporary Fastening to Decks

- a. Contractors often request permission to use anchor supports for face forms, concrete curbs, Jersey barriers, raised medians on bridges. Any contractor desiring to use a temporary floor fastening may be allowed to use only some form of weakened section bolt or tie, cast in the floor. The weakened section must be so positioned that when broken off the break will be recessed below the surface. The resulting void must be patched with mortar. No hold down device shot into the floor will be allowed.

706.04 METHOD OF MEASUREMENT

706.05 BASIS OF PAYMENT

707.00 REINFORCEMENT

707.01 DESCRIPTION

- 1. The reinforcement of concrete for structures consists of furnishing and placing deformed metal reinforcing bars or welded-wire fabric in the concrete as required by the plans and specifications.

707.02 MATERIAL REQUIREMENTS

- 1. Samples of reinforcing steel and welded-wire fabric are required by the Central Laboratory unless these materials are shipped from tested stock. Stock, or pretested material is no longer tagged by NDOT. As long as the material is received with a signed shipping report from the supplier the material can be used (provided the form includes proper Materials & Research Lab report numbers). The project personnel are then responsible for making sure these shipping reports are uploaded to OnBase®." Steel arriving that is not pre tested stock should not be incorporated in the work until approved by the Materials Engineer. See the [Materials Sampling Guide](#). See also Materials and Research [quick reference guide](#).

2. The Materials and Research Division requires that two 6 ft (2.0 m) sample lengths of epoxy-coated reinforcing steel be submitted for testing purposes, see [Materials Sampling Guide](#)
3. Similarly, the [Materials Sampling Guide](#) requires two 6 ft (2.0 m) sample lengths for uncoated reinforcement bars be provided (unless shipped from tested and approved stock). Enter the date resteel is verified on-site in SiteManager.

707.03 CONSTRUCTION METHODS

1. Placement and Checking (Bridge Deck)
 - a. Bridge plans specify nominal slab thickness and nominal clearance of reinforcing bars from face of the concrete. This section will establish acceptable deviations from nominal plan dimensions.
 - b. Four dimensions must be given special attention when checking placement of bridge slab reinforcing:
 - (i) Slab thickness.
 - (ii) Clearance of bottom reinforcement from bottom of slab.
 - (iii) Distance from bottom of slab to top of top mat of reinforcement.
 - (iv) Cover over top mat of reinforcement. If insufficient, raise the paver, do not push the top mat down. The “core depth” – distance center to center between top and bottom of mat of steel is important to the design.
2. Slab Thickness
 - a. This shall be the nominal slab thickness shown on the plans with a tolerance of minus zero and plus 1/2 inch (13 mm).
3. Clearance of Slab Reinforcement
 - a. The reinforcing steel shall be placed to monitor the nominal clearances shown in the plans $\pm 1/4$ inch (5 mm). Contractors must provide an adequate number of bolsters and/or bar chairs of suitable height and strength to maintain clearance within this range.
 - b. Contractors must provide an adequate number of bar chairs of suitable height and strength to maintain the distance within this range of tolerance. Not greater than 3 feet on center for #4 bars and 4 feet on center for all other bars.
4. Protection of Material (*SSHC Subsection 707.03*)
 - a. The Specifications provide that steel reinforcement shall be protected at all times from damage. When placed in the work, it shall be free of dirt, loose scale, detrimental rust, paint, oil or any foreign material. Detrimental rust is defined as heavy reddish coating formed on iron or steel when chemically attached by moist air. This must be removed by wire brushing. However, a light layer of rust or mill scale that is not readily removed with a wire brush is acceptable.

5. Placing and Fastening (*SSHC Subsection 707.03*)
 - a. Positioning - It is essential that inspectors give special attention to the placement of reinforcing steel in all structures. Reinforcement shall be placed in the exact position shown in the plans and held securely in that position to prevent movement or shifting during placement of the concrete. For example, on a 7 inch (175 mm) thick bridge floor, designed with the top steel 1 3/4 inch (45 mm) below the surface, a sag or displacement in the top steel of only 1/2 inch (13 mm) will reduce the strength of the floor 19 percent. The reduction in strength of thinner sections such as culvert slabs and walls is even more critical.
 - b. Reinforcing bars shall be tied at all intersections, except when the spacing is less than 1 foot in both direction. The Project Manager should thoroughly study the project documents in order to be aware of this requirement as well as any change which might occur.
 - c. Horizontal reinforcement in slabs shall be spaced vertically by means of approved metal chairs. The type and adequacy of bar support systems which includes the spacing of bar supports shall be in accordance with the Concrete Reinforcing Steel Institute's "Manual of Standard Practice", unless other stipulations are provided in the contract provisions. Contact the Construction Division Structures and Grading section for guidance on this Manual. Bar supports which are located at exposed concrete surfaces shall be galvanized, plastic coated or stainless steel to a depth of 1/2 inch (13 mm) minimum from the concrete surface. Chairs may also be used to keep vertical columns and wall steel from contacting the form.
 - d. Field welding will be permitted only when shown on the plans or with written permission of the District Construction Engineer. Reinforcement can best be checked as the work progresses rather than waiting until the contractor has enclosed the reinforcement within the forms. In the case of walls and columns it is virtually impossible to do the inspection after the forms are in place. When bent bars are used, a check should be made that there are no cracks or splits at the bends. Stirrup hooks should be rotated to different positions in order that the hooks do not fall in the same location when a series of stirrups are used in beams or columns.
 - e. *SSHC Subsection 704.03* requires the contractor to give the Project Manager sufficient advance notice (1 NDOT work day) before starting concrete operations in any unit of a structure, to permit the inspection of forms and reinforcing bars. The Project Manager shall require all reinforcing steel to be accurately placed and firmly held in position.
6. Special Attention Areas
 - a. Ties and Supports
 - (i) *SSHC Subsection 707.03* require that the top mat of #4 bar reinforcing steel is supported at not greater than 3 feet spacing measured in each direction. All other steel is to be supported at a spacing not greater than 4 feet in each direction. Reinforcing bars shall be tied at all intersections, except when the spacing is less than 1 foot in both directions, in which case alternate intersections shall be tied.

- b. Epoxy Coated Bar
 - (i) Epoxy coated reinforcing steel requires the use of epoxy or plastic coated bar supports and tie wires (*SSHC Subsection 707.03*). Epoxy coated tie wires may tend to slide or break. If this occurs, they should be double tied or stronger ties used.
 - c. Clearance Check
 - (i) The specified clear distance from surface to reinforcing steel must be maintained. To check this, a clearance guide 1/4 inch (5 mm) less in thickness than the specified clearance to top steel should be temporarily fastened to the bottom of the finishing machine screed. The finishing machine should then be operated along the bridge to insure that proper clearance is obtained. It will be necessary to bend all tie wire loops down to permit the clearance gauge to pass. Any steel not properly placed must be corrected.
 - d. Checks During Placement
 - (i) Checks of slab thickness and cover over top reinforcement must be made in the finished concrete directly behind the finish machine. A thickness and cover check should be made at the same location of an approximate grid of 10 feet (3 m) transverse and 20 ft (6 m) longitudinal. These checks must be documented in the DWR. When the slab is of deficient thickness or cover checks indicate incorrect rebar placement corrections must be made immediately.
 - e. Cleaning Forms and Steel
 - (i) Mud and other foreign material must be removed from the steel and forms prior to placement. Remove any trapped/ponded water before placing the concrete.
7. Epoxy-Coated Reinforcement (*SSHC Section 1021*)
- a. Epoxy coatings are applied to reinforcing bars by a fusion-bonded process. This means the coating achieves adhesion to the bar as a result of a heat-catalyzed reaction. Besides chemical adhesion, there is also physical adhesion of the coating to the bar.
8. Care and Handling
- a. Epoxy coated bars are subjected to many quality control tests and inspections prior to leaving the supplier's facility. However, from that point forward, careless handling and construction practices can cause excessive coating damage. Contractors should be strongly encouraged to exercise care in handling, storage, and placing of epoxy coated bars. If problems are noted after delivery, the inspector is to contact the Materials and Research Division.
 - b. Handling
 - (i) During unloading epoxy coated bars from the truck, care must be exercised to minimize scraping of the bundles or bar-to-bar abrasion from sags in the bundles. Skidding bundles from the truck onto the ground should not be allowed. Use of power

hoisting equipment for unloading and handling is strongly encouraged. Further, equipment for handling the bars should have protective contact areas. Specifically, nylon slings or padded wire rope slings shall be used and bundles should be lifted at multiple pick-points.

c. Storage

- (i) Epoxy coated bars should be stored on timbers or other suitable protective cribbing. All types of reinforcing bars should be stored off the ground as close as possible to the area where they will be used. The following storage practices are suggested to prevent damage:
- (ii) Store bars above the ground on timbers, cribbing, or dunnage placed close enough together to prevent sags in the bundles.
- (iii) If a large quantity of bars has to be stored in a small area, bundles can be stacked if adequate blocking is placed between the layers.
- (iv) While fading of the coating's color is not specifically detrimental, it should be avoided to the fullest extent possible. One recommended method is to cover exposed bundles with burlap or dark plastic. (1021.03)

NOTE: If plastic or other nonporous material is used for covering, the ends must be left open to allow air movement. Without this, condensation under the cover could cause damage.

- (v) Long-term site storage (from one year to the next) of epoxy coated bars is not recommended. If circumstances require storing coating steel reinforcing bars outdoors for more than two months, protective storage measure shall be implemented to protect the material from sunlight, salt spray and weather exposure.

d. Placing

- (i) Placing of epoxy coated bars is done similar to uncoated bars. The KEY exception is that coated bars require more careful handling and placing. Once bundles have been opened, dragging one bar over another or over any abrasive surface MUST be avoided.
- (ii) After epoxy coated bars are placed, walking on the bars by construction personnel should be held to a minimum. Bars in high traffic areas or runways for concrete placement should be protected with plywood or other suitable material. Concrete placement equipment shall not be placed on, or supported by, any reinforcing steel.
- (iii) Bar supports and tie wires for epoxy coated reinforcement shall be coated with epoxy, nylon, or plastic.

9. Field Inspection
 - a. Epoxy coated bars should be inspected for damaged coating:
 - (i) when received at the job site, and
 - (ii) after they are placed in the structure.
 - b. Damage Evaluation and Repair
 - (i) Damaged coating shall be evaluated as outlined below. The "holiday detector" may be used to determine coating flaws.
 - (ii) Bent Bars
 - (1) Examination of physical coating condition on the outside radii of hooks and other bends might reveal cracks in the coating. When cracking of the coating is evident, the contractor must remove loose coating, clean the area, and repair.
 - (iii) Fading of Color
 - (1) When epoxy coated bars are exposed to sunlight over a period of time, light fading of the color may occur. While fading of the epoxy coating should be avoided, it is not necessarily detrimental. Since discoloration does not harm the coating nor affect its corrosion protection properties, such fading will not be cause for rejection.
 - (iv) Damaged Ends
 - (1) Damage to ends because of field shearing, dragging or whatever must be repaired in the field.
10. Repair of Damaged Coating
 - a. When a damaged coating must be repaired, the patching or touch-up material should be applied in strict accordance with the instructions furnished by the manufacturer. Generally, surface preparation consists of a **THOROUGH** manual cleaning of damaged areas, including complete removal of: (1) unbonded epoxy and (2) all rust. Cleaning is usually accomplished with a power driven wire brush, hand steel brush, and/or emery paper. Care should be exercised during preparation so that excessive sound epoxy is not damaged. Acceptance criteria for epoxy repair and touchup materials is in accordance with the original epoxy resin manufacturer's recommendations.
 - b. Epoxy coated reinforcing steel is used in concrete bridge decks to prevent spalling of the concrete which is, in turn, caused by the corrosion of the reinforcing steel. The epoxy coating prevents the corrosion of the reinforcing steel. Two factors influence the capability of the coating to prevent corrosion. One of these factors is the thickness of the coating. The other factor is the integrity of the coating, i.e., the absence or presence of defects in the coating which would allow moisture and de-icing chemicals to reach the metal itself.
 - c. The epoxy coating on the rebars may have three types of defects when the bars arrive at the site. The first type of defect defined in the

Specifications is a "holiday." A holiday is a small hole in the coating which is not visible to the naked eye. This type of defect is the result of some inadequacy in the application process. Holidays can be detected only with an electronic detector and the Specifications permit one holiday per 1 foot (300 mm). The inspector shall inspect the bars and determine if holidays testing is necessary.

- d. The second type of defect, which may be present in the epoxy coating when the bar arrives at the site, is defined as handling damage. Handling damage may take the form of scuffs, scars, scratches or any other wound to the coating caused by rough handling. The Specifications permit a "reasonable" amount of handling damage. Handling damage is generally visible to the naked eye since rust will form over the damaged spot after a sufficient amount of time passes. A fresh cut or scar in the coating would probably be difficult to locate visually, but would be readily picked up with an electronic detector. NDOT Project Construction Staff will visually inspect bars as they arrive on site and as they are incorporated into the project.
 - e. The third type of defect, which may be present in the epoxy coating when the bar arrives at the site, is due to what may be considered as an "uncoatable" bar. During the rolling process, some bars are formed with very sharp edges on the deformations and ribs.
 - f. These edges are very difficult to coat adequately, and coating applicators usually avoid coating bars so formed. The defect in coating on these edges may or may not be visible to the naked eye. This particular defect can be detected with an electronic detector. When this defect is present, the detector will indicate this flaw by a constant 'beeping' when run along a rib. In most instances, the thickness of the epoxy coating will be very low in these areas or there may be no coating at all where the sharp edges are present. NDOT Project Construction Staff will visually inspect bars as they arrive on site and as they are incorporated into the project.
11. Holiday testing:
- a. A total of six defects in any 1 foot (300 mm) of the bar will be permitted. As an example, in a bar of given length, if any 1 foot (300 mm) section of that bar has no more than the two allowable holidays and four handling defects, the bar is acceptable, providing none of the four handling defects has an area greater than 0.0025 ft.² (225 mm²). [A square measuring 0.05 ft x 0.05 ft (15 mm x 15 mm) has an area of 0.0025 ft.² (225 mm²)]. All handling defects having an area greater than 0.0025 ft.² (225 mm²) must be repaired.
 - b. The following points may be helpful in the inspection and repair of epoxy coated rebars in the field.
 - (i) Visually inspect bars for coating defects as they come out of the bundle. Obtain shipping reports, Certificate of Compliance and or test bars, according to the [Materials Sampling Guide](#) as soon as steel shows up on the project. Insure the steel has been approved prior to incorporating it into the project.

- (ii) It may not be necessary to check all bars in each bundle, but enough bars out of each bundle should be checked in order to determine the quality of coating on all bars in the bundle.
 - (iii) When the number of defects per 1 foot (300 mm) section exceeds six, only the number of defects necessary to bring the bar into compliance need be repaired. Only exception is that all defects greater than .00005 in² (.035 mm²) must be repaired.
 - (iv) Repair of defects is accomplished with an approved two component epoxy compound supplied by the coating manufacturer.
 - (v) Epoxy compounds used for repair have a minimum temperature at which they may be used and a limited pot life, as recommended by the manufacturer.
 - (vi) Any rust showing through the defect must be removed before applying the epoxy compound. The surface shall be cleaned in accordance with the recommendations of the material manufacturer.
 - (vii) Coating thickness of the painted repair area must be as specified for the factory applied coating.
 - (viii) Coating on bars may be damaged during placement at the site. Such damage to the bars must be repaired when the bars are in place, if the six defects per 1 foot (300 mm) section limitation is exceeded.
 - (ix) Coating thickness of the bars were not inspected at the coating applicator's plant. This should be done as they come out of the bundle. Coating thickness is checked with a magnetic thickness gauge. If there is question that the bars are not coated properly, contact Materials and Research. Materials and Research has a magnetic thickness gauge they loan out.
 - (x) To obtain a holiday detector, contact the nearest branch laboratory or the Construction Division magnetic thickness gages may be obtained by requisition from the Materials and Research, "Inspector" or "Microtest" thickness gauges which are used for checking paint film thickness cannot be used for checking epoxy coating thickness on reinforcing steel.
- c. For situations where there is no information available as to what type of touch-up material should be used, 3M Corporation has two products available:
- (i) SCOTCHKOTE 213 is often used to repair minor nicks and gouges.
 - (ii) SCOTCHKOTE 312 is a two component epoxy that has been used to repair both small and large areas of damage.

NOTE: Repaired areas do not have as much corrosion or abrasion resistance as factory-applied coatings.

12. Bar Designation System

- a. You must be very careful when you review a bar list. Currently, steel bar in the USA is usually measured in English units. Do not assume anything; measure to be sure you are getting the correct size. In general, the mark number for reinforcing bars as shown in the plans generally uses the following designation system. The first letter or letters identify the general location of the bar such as abutment, pier, bent, slab or approach slab bar.

<u>Location</u>	<u>Code</u>
Abutment	A
Pier	P
Bent	B
Slab	S
Approach Slab	N

- b. The first number or numbers indicate the size of the bar and the last two numbers indicate whether the bar is bent or straight. (Even numbers are straight bars and odd numbers are bent bars.)
- c. For example, P1002 would be a straight No. 10 bar located in the pier; A415 would be a bent No. 4 bar located in the abutment. The last two numbers also indicate the approximate length of the bar. The lower the number the longer the bar; for example, a S602 bar would indicate the longest, straight, No. 6 bar used in the slab, whereas a S612 bar would indicate that there are five groups of straight, No. 6 bars that are longer than the S612 in the slab.

13. Splicing

- a. All reinforcement shall be furnished in the full lengths indicated in the plans. Splices, not shown in the plan, shall not be allowed without approval of the Project Manager. Welding shall be allowed only if shown in the plans or authorized by the Construction Engineer in writing.
- b. When splices are required, they should be staggered as far as possible in order that a plane of weakness is not caused in the member. The laps should be at least as long as is shown in the plans. Splices should preferably be made in areas of low stress concentration. The bars in the top of a slab or beam should be spliced in a positive moment section (bottom of slab or beam in tension) and the bars in the bottom of a slab or beam should be spliced in a negative moment section (top of slab or beam in tension). For example, the longitudinal bars in the top of a slab should be spliced near the center of the span rather than over a pier and the longitudinal bars in the bottom of the slab should be spliced near the pier rather than in the middle of a span. Following is a tabulation of 36 diameter lap requirements for the various sizes of rebars.

ASTM Standard Reinforcing Bars				
		Nominal Dimensions - Round Sections		
Bar Size Designation	Weight Pounds per Foot	Diameter Inches	Cross-Sectional Area - Sq. Inches	Perimeter Inches
#3	.376	.375	.11	1.178
#4	.668	.500	.20	1.571
#5	1.043	.625	.31	1.963
#6	1.502	.750	.44	2.356
#7	2.044	.875	.60	2.749
#8	2.670	1.000	.79	3.142
#9	3.400	1.128	1.00	3.544
#10	4.303	1.270	1.27	3.990
#11	5.313	1.410	1.56	4.430
#14	7.650	1.693	2.25	5.320
#18	13.600	2.257	4.00	7.090

LAP REQUIREMENTS		
Metric Bar Size	English Bar Size	36 Diameter Lap Grade 60 Steel
10	2	9 in (225 mm)
10	3	14 in (350 mm)
10	4	18 in (450 mm)
15	5	23 in (575 mm)
15	6	27 in (675 mm)
25	7	32 in (800 mm)
25	8	36 in (900 mm)
30	9	41 in (1025 mm)
30	10	44 in (1100 mm)
35	11	49 in (1225 mm)

- c. There are times when splicing of rebar in a manner other than lapping is necessary. Examples include:
 - (i) Complicated placement where the cage could be tied off site, in sections, and set in place.
 - (ii) Reinforcement cages for drilled shafts.
 - (iii) Situations where an existing rebar is not long enough to develop strengths by lapping.
- d. Example: During removal of an existing curb on a bridge deck widening project existing rebar is either cut with the saw or broken during concrete demolition. In this case additional demolition is needed to provide a lap development length.
- e. Mechanical splices are only authorized where shown in the plans. A list of acceptable Mechanical Splices will be listed on the plans. The Mechanical Splices will need to be sampled and tested according to the [Materials Sampling Guide](#). Currently, several couplers are manufactured which can be used to mechanically splice rebar. Mechanical splices, for field approval, shall develop 125% of the rebar's yield strength. Consideration for splice usage must be initiated by the contractor. The Project Manager is to forward that request to the Construction Division for review.

707.04 METHOD OF MEASUREMENT

1. Reinforcing steel for concrete structures is measured by the pound. Quantities to be paid for are computed from the theoretical mass of bars and wire mesh. The mass of steel reinforcement required for structures is shown in the plans. Plan quantity shall be used for final quantity reinforcing steel for bridges unless changes are made to design.

707.05 BASIS OF PAYMENT

708.00 STEEL STRUCTURES

708.01 DESCRIPTION

1. This work includes the furnishing, preparing and erecting of all riveted, bolted or welded structures in which the main members spanning the supports are composed of steel.

SSHC References: See *SSHC Table 708.01*

Other References: AWS Standard Specifications. (ANSI/AASHTO/AWS D1.5 Bridge Welding Code)

Inspection Crew: Fabrication Inspector
Project Manager (PM)
Lab Inspector

Inspection Equipment: Skidmore-Wilhem Calibrator

Shop Procedures:

1. Check Fabricators QC Plan.
2. Make sure QC Plan is followed.
3. The mill order list or the Certified Mill Test Reports must be furnished before fabrication begins.
4. Document all actions not in compliance with the QC Plan or Standard AWS procedures.
5. Welding symbols are shown in Section 708.

Field Construction Procedures:

1. Confirm steel was inspected on site and in shop. Enter date in SiteManager.
2. Sample bolts, nuts, and washers and send to Materials & Research.
3. Heavy hexhead bolts require heavy hexhead nuts and a hardened washer under the element that is turned.
4. Check all bolts, washers, and nuts to make sure there is proper and correct marking on each.
5. Before the contractor begins steel erection, the Project Manager will make a final check of span lengths, skew angles, and bearing point elevations.
6. Also, take pictures of pavement under any structure where equipment will be lifting members.

7. Bearings, expansion devices, etc., shall be set according to the temperature at time of installation. (See Plans.)
8. Check matchmarks on all girders, separators, angle braces, etc.
9. Verify that drift pins do not enlarge holes or distort the metal.
10. Stop the contractor from hammering if it appears the metal will be damaged or injured.
11. The Construction Division will be notified of all major misfits and determine what procedures will be allowed.

708.02 MATERIAL REQUIREMENTS

1. Members of steel structures that are fabricated in the shop are inspected by NDOT Steel Fabrication Manager before they are shipped to the job site. In some cases, when the fabrication is done outside of the state, the inspection will take place after delivery to the site of work. The Project Manager should have a copy of the shop inspection report and the mill test report before allowing the erection of any portion of the structure. Miscellaneous parts of the superstructure such as high tensile steel bolts will require field inspection and sampling according to the [Materials Sampling Guide](#) (These bolts are typically sampled and tested by NDOT Steel Fabrication Manager).
2. Field welding may require the use of special welding electrodes as designated in the plans, specifications, or special provisions. Some of these welding electrodes may require special care and handling before their use will be permitted. (See Field Welding Guide.)

708.03 CONSTRUCTION METHODS

1. Bridges-Steel Beam
 - a. On bridges using weathering steel (A 588) for steel structures, the contractor shall:
 - (i) Use "high strength," A325M Type III bolts, A563 Grade DH3 nuts, and F463 Type III washers.
 - (ii) Limit shop painting to only areas shown in the plans. Shop painting will be with the paint system specified in the special provisions. Field touch-up will be required for paint that is damaged and to fasteners in these areas and it will be done with same color and type of paint as the original painting.
 - (iii) Require special care to assure concrete slobbers are eliminated (or at least removed) from steel surfaces before the concrete hardens. Washing with water is the preferred method of removing concrete slobbers.

2. Structural Joints Using High Tensile Steel Bolts

BOLT DIAMETER (INCHES) D	HEAVY HEX STRUCTURAL BOLTS BOLT DIMENSIONS (INCHES)			HEAVY HEX NUTS NUT DIMENSIONS (INCHES)	
	WIDTH ACROSS FLATS F	HEIGHT H	THREAD LENGTH	WIDTH ACROSS FLATS W	HEIGHT H
1/2	3/8	3/16	1	3/8	31/64
5/8	1 1/16	25/64	1 1/4	1 1/16	39/64
3/4	1 1/4	1/2	1 3/8	1 1/4	47/64
7/8	1 3/8	35/64	1 1/2	1 3/8	55/64
1	1 5/8	39/64	1 3/4	1 5/8	63/64
1 1/8	1 7/8	1/2	2	1 7/8	1 7/64
1 1/4	2	7/32	2	2	1 1/32
1 3/8	2 3/16	7/32	2 1/4	2 3/16	1 1/32
1 1/2	2 3/8	1/2	2 1/4	2 3/8	1 1/32

TYPE 3
 TYPE 2
 TYPE 1
 Manufacturer's Identification Symbol
 TYPE 3 WASHER
 (A 3 or other suitable marking should be visible)

Standard Nut Marking
 Manufacturer's Identification Symbol on "2" and "2H" ONLY
 Alternate nut marking
 "2", "D", "2H", or "DH".
 (a)
 (b)
 TYPE 3 NUT
 Marked with "3" and three circumferential marks.
 Nuts may be washer faced as in (a) or double chamfered as in (b).

Bolt Marking
 Manufacturer's Identification Symbol
 Manufacturer's Identification Symbol For "2H" ONLY
 Nut Marking "2H" Or "DH"
 (a)
 (b)
 Nuts may be washer faced as in (a) or double chamfered as in (b)

g:\bolts.dgn Jan 30, 1998 10:50:29

Bolts

- a. *SSHC Section 1058* requires high tensile steel bolt, nut and washer material for structural steel joints to meet the requirements of ASTM Designation A 325/A 325M.
- b. When heavy hex head structural bolts and heavy hexagon nuts are used, a hardened washer is required only under the bolt head, or nut, whichever is the element being turned. Bolts and nuts may be washer faced, but these faces do not take the place of a hardened washer.
- c. Heavy hex head structural bolts manufactured to ASTM A 325/A 325M, Types 1, 2 and 3, the dimensions for which are shown in the ASTM tables, are identified on the top of the head by the legend "A 325", and the manufacturer's symbol.
- d. Type 1 bolts, at the option of the manufacturer, may be marked with three radial lines 120 degrees apart.
- e. Type 2 bolts shall be marked with three radial lines 60 degrees apart. Type 3 bolts shall have the "A 325" underlined and the manufacturer may add other distinguishing marks indicating that the bolt is of a weathering type.
- f. Heavy hex nuts for A 325 bolts are identified on at least one face by the manufacturer's mark and the number "2" or "2H", by three equally spaced circumferential lines, or by the legend "D" or "DH". Heavy hex nuts for A 325 Type 3 bolts shall be marked on one face with three circumferential marks and the numeral "3", in addition to any other distinguishing marks the manufacturer may elect to use.
- g. Washers for A 325 Type 3 bolts shall be marked on one face near the outer edge with the numeral "3", or other distinguishing marks indicating that the washer is of a weathering type.
- h. The marking on bearing surfaces of nuts and washers shall be depressed.
- i. According to the specifications, high strength steel bolts shall be installed by the turn of the nut method. It should be noted that the equivalent tension values given in *SSHC Table 708.03* are experimental approximations and that the footnote to this table required that the torque-tension ratio be determined under actual conditions of the application. Wrenches will be calibrated and the torque-tension ratio will be determined at the site by Materials and Research Division personnel. The Construction Engineer should be notified as early as possible as to the time when the wrench and representative bolts will be present at the site in order that arrangements may be made to have appropriate personnel travel to the site and calibrate the wrench and establish the torque-tension ratio.
- j. When Materials and Research Division personnel have calibrated the wrench and determined the torque-tension ratio, the bolt tension calibrator will be left with the project personnel so that the wrench calibration may be checked as the work goes on. Impact wrenches should be checked on a daily basis and manual torque wrenches at any time

that, in the opinion of the Project Manager, conditions have varied from those present during the initial calibration.

- k. *SSHC Subsection 708.03* requires that the structure shall be adjusted to the requirements of blocking diagram before placing permanent bolts in field connections. This should be checked by the contractor and verified by the inspector prior to completing final phase of bolt tightening.
 - l. All splice plates and contact surfaces shall be clean.
3. High Strength Fasteners (*SSHC Section 1058*)

METRIC HEAVY HEX BOLTS

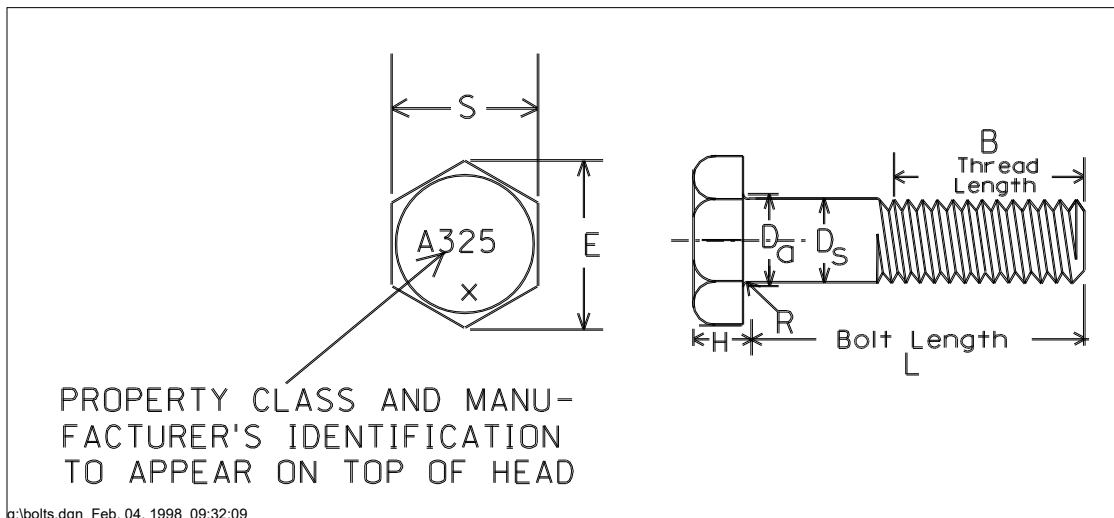

D Nominal Bolt Size & Thread Pitch	D _s		S		E		H		D _a	R	B (Ref.)		
											Thread Length (Basic)		
	Max.	Min.	Max.	Min.	Max.	Min.	Max.	Min.	Max.	Min.	Bolt Lengths <125	Bolt Lengths >125 and <200	Bolt Lengths >200
M12x1.75	12.70	11.30	21.00	20.16	24.25	22.78	7.95	7.24	13.7	0.67	30	36	49
M14x2	14.70	13.30	24.00	23.16	27.71	26.17	9.25	8.51	15.7	0.6	34	40	53
M16x2	16.70	15.30	27.00	26.16	31.18	29.56	10.75	9.68	17.7	0.6	38	44	57
M20x2.5	20.84	19.16	34.00	33.00	39.26	37.29	13.40	12.12	22.4	0.8	46	52	65
M24x3	24.84	23.16	41.00	40.00	47.34	45.20	15.90	14.56	26.4	0.8	54	60	73
M30x3.5	30.84	29.16	50.00	49.00	57.74	55.37	19.75	17.92	33.4	1.0	66	72	85
M36x4	37.00	35.00	60.00	58.80	69.28	66.44	23.55	21.72	39.4	1.0	78	84	97

- a. *SSHC Subsection 708.03, Paragraph 10.h.* Turn-of-Nut method shall be followed for tightening all high strength fasteners.
- b. High Strength bolts and nuts, which have been torqued as outlined below, shall not be reused. This includes both black and galvanized bolts and nuts.

- (i) Bolting
 - (1) Receiving Shipments
 - (a) Prior to installation, check shipping certifications and compare these to bolting kegs on site. Check for size, length, heat numbers, and general fastener condition i.e., rusted black bolts or non-lubricated galvanized nuts. Rotational-Capacity (RC) lots will need to be checked (Typically sampled by NDOT Steel Fabrication Manager prior to shipping to job site).
- (ii) Installation Checklist
 - (1) A pre-bolting meeting is strongly recommended/ encouraged. Bolting procedures, Turn-of-Nut process described below, and the inspection process need to be discussed.
 - (2) Site storage of fasteners is important. Storage should be in a sealed container within a sheltered storage shed.
 - (3) Black bolts and nuts shall be oily to the touch when delivered and installed.
 - (4) Galvanized nuts shall be checked to verify lubrication. A uniform dye color indicates lubricant has not been damaged. If there is no color, or color is not uniform, bolts and nuts shall be field lubricated with bees wax, stick wax, or other approved dry wax prior to installation.
 - (5) Rusted or dirty bolts or nuts shall be cleaned and re-lubricated prior to installation.
 - (6) Faying surfaces shall be free of burrs and foreign material; and bolted faying surfaces are to have no more than 2 mils of primer max.
 - (7) All fasteners shall be free of dirt, moisture, rust, and be "well" lubricated.
 - (8) Washers (when required) are to be placed under the **"turned element."**
 - (9) Often contract documents will specify which way a bolt is to be installed. If there is no specific guidance, threaded ends of bolts will be turned inside and away from normal exposure to pedestrian and/or vehicular traffic for aesthetic reasons.
 - (10) During installation, particular care should be exercised so a snug-tight condition is achieved.

(iii) Rotational-Capacity

- (1) All lots and combination of lots are sampled and tested in accordance with [Materials Sampling Guide](#) (This sampling is typically performed by NDOT Steel Fabrication manager). Additional Rotational Capacity (RC) test may be required by the Project Manager if there are disagreements about the tension of the installed bolts
- (2) There are two separate Rotational-Capacity requirements:
 - (a) Fasteners (bolts, nuts, and washers) received at the project shall have been RC tested by the supplier or manufacturer prior to shipment. Therefore, each combination of production lots must have a unique RC lot number. This number must be readily identifiable on each container of fasteners.
 - (b) Prior to installation, the contractor shall field test all RC lots as supplied. Field tests are not intended to match the values provided by the supplier, but as a separate and added acceptance test.
 - (c) Field testing procedures are given in *SSHC Subsection 708.03, paragraph 10.i.*

(iv) Turn-of-Nut Method

- (1) Turn-of-Nut method involves the following simple steps. Adherence to this procedure will assure a properly fitted and clamped connection. (*Refer to SSHC Subsection 708.03.*)
 - (a) Adequate number of bolts and pins shall be installed to bring a joint in tight contact and alignment. These bolts shall be brought to a snug-tight condition to insure that the joint is maintained in good contact during installation of remaining bolts. A washer shall be placed under the element to be turned.
 - (b) Remaining bolts in a connection shall be installed and brought to a snug-tight condition.
 - (c) Check initially installed bolts to assure they remained in a snug-tight condition.
 - (d) Tighten all bolts by the applicable Turn-of-Nut amount specified in *SSHC Subsection 708.03.* Additional rotation depends on the bolt length to diameter ratio and shape of connected pieces. For MOST installations (both faces normal to bolt Axis) the following table can be used to determine additional rotation for Turn-of-Nut.

Turn of the Nut			
3/4" Dia. Bolts		7/8" Dia. Bolts	
Bolt Length	Additional Rotation	Bolt Length	Additional Rotation
0-3"	1/3 turn	0-3.5"	1/3 turn
>3"-6"	1/2 turn	>3.5-7"	1/2 turn
>6" -9"	2/3 turn	>7" - 10.5"	2/3 turn
NOTE: All additional rotations have a \pm tolerance. Refer to <i>SSHC Section 708</i> .			
1" Dia. Bolts		1 1/8" Dia. Bolts	
Bolt Length	Additional Rotation	Bolt Length	Additional Rotation
0-4"	1/3 turn	0-4.5"	1/3 turn
>4"-8"	1/2 turn	>4.5"-9"	1/2 turn
>8" -12"	2/3 turn	>9" - 13.5"	2/3 turn
NOTE: All additional rotations have a \pm tolerance. Refer to <i>SSHC Subsection 708.03</i> .			

(v) Snug Tight

- (1) Snug tight is defined as the tightness that exists when all plies of a joint are in "firm" contact with each other. There shall not be air gaps between metal to metal or metal to bolt surfaces. For properly fitting surfaces, snug tight can usually be accomplished by:
 - (a) The full effort of a person using an ordinary spud wrench.
 - (b) A "few impacts" of an impact wrench. To quantify "few impacts," tighten a few bolts using the full effort method on a spud wrench. Then apply the job impact wrench, and roughly check how many impacts it takes to develop at least the same effort.
- (2) After **ALL** bolts in the connection are snug tight:
 - (a) **ALL** nuts shall be match-marked with bolt point nut and base steel using paint crayon, or other means to provide a straight reference line for determining final relative rotation of parts during tightening.
 - (b) All bolts in a connection shall then be tightened additionally by an applicable amount of nut rotation specified above. Tightening should progress from the most rigid part of the joint to its free edges. On our normal web and flange splices, this would mean beginning at the centerline of a splice and progressing away (in each direction) from the centerline of splice.
- (3) Inspectors should observe this operation at intervals to make certain the match-marking is done correctly, and that

the opposite bolt head or nut does not turn during the tightening process. Inspectors also should check to see if proper rotation has been made considering tolerances given at the bottom of the nut rotation chart.

(vi) Inspection Wrench Calibration

(1) Tension Measuring Calibrated Devices

- (a) Tension measuring calibrated devices (typically Skidmore-Wilhelm Calibrator) are calibrated to a high degree of accuracy, but can lose some of this accuracy after an extended period of time. Contractors can have the devices calibrated by the Materials & Research Laboratory.
- (b) When each device is calibrated, a calibration sheet will be issued indicating the date the test was performed. Contractors must keep the calibration sheet with the tension-measuring device.
- (c) Attentiveness needs to be exercised when using this Calibration Sheet. The inspector needs to check the sheet and compare the "Indicated Load on Gauge" column to those values listed in the "AVG" column under "Actual Load on Testing Machine." These are usually **NOT** the same.

NOTE: There must be 3-5 threads exposed behind the nut. Check and add washers if required. For longer bolts, steel shim plates should be used.

(vii) Turn-of-Nut Inspection (*SSHC Subsection 708.03*)

- (1) After all fasteners in a joint are properly tightened by the Turn-of-Nut method, they shall be inspected as indicated:
 - (a) Installed fasteners shall be inspected the same day as installed by the contractor with the inspector present.
 - (b) The contractor shall use a calibrated torque wrench for the inspection operation.
 - (c) Ten percent of the bolts which have been tightened in the structure shall be tested with the inspection wrench the same day as installed. At least two bolts, selected at random, in each connection shall be tested. If no rotation (nut or bolt head) is noted by job inspecting torque wrench and the faying surfaces are in tight contact the connection shall be accepted as properly tightened. If any nut or bolt head is turned, all bolts in the connection shall be checked, and all bolts whose nut or head is turned shall be tightened and reinspected.

- (d) Bolts tightened by the Turn-of-Nut method may reach tensions substantially above minimum torque values specified, but this shall not be cause for rejection.
 - (e) Care should be taken, however, to not overstress the bolts. If most of the bolts exceed 20% of minimum bolt tension, the contractor's procedures should be reviewed to determine:
 - Is the snug-tight procedure correct?
 - Are there nicks or burrs on the threads?
 - Are the nuts or bolts rusty or dirty?
 - Check for residual lubrication. All threaded fasteners (black and galvanized) are required to be lubricated. Black bolts and nuts need to have a water soluble oil, and galvanized nuts are to be lubricated as per ASTM A 563. Prelubricated galvanized nuts will be dyed typically to a blue color. If there is no indication of color OR if the color is faded, the bolts shall be field lubricated with bees wax, stick wax, or some other dry lubricant.
 - Is calibrating device correct?
- (4) Bolts and nuts must always be inspected prior to installation. Items of major concern are:
- Nicks or burrs in the threads
 - Rust
 - Presence of dirt or other foreign material
 - Fastener lubrication
 - All dirt, foreign material, and rust must be removed prior to use. Black bolts may require re-oiling to remove rust etc. If re-oiling is required, excess oil must be removed prior to installation. When rust cannot be removed by oiling, the bolt or nut must be rejected. Bolts or nuts with nicks or burrs on threads must be rejected. Re-lubrication will necessitate rechecking fasteners in the lot for Rotational-Capacity.
- (5) Plan ahead before girder splices have been fully tightened. Make necessary adjustments prior to tightening the bolts in a connection. The best way to assure that beam lines are straight and true is to:
- (a) Scribe a line at the center of each bearing on all masonry plates or concrete.

- (b) Set beams and make snug tight connections proceeding to the forward pier. Then go back and straighten the beam line, checking to be sure bearings remain centered on their seats. Once the previous span is aligned and tightened, proceed to the next forward span.
 - (c) Check to be sure beam ends are aligned prior to tightening the splice.
 - (d) This will require coordination between survey and inspection crews and the contractor.
- 4. Galvanized Bolts
 - a. *When using galvanized hardware, a lubricant approved by ASTM A 563 shall be applied to the nuts.* Galvanized nuts "typically" are delivered to the project pre-lubricated. Usually, pre-lubricated nuts are stained and have a distinguishing color. If a lubricant has been applied at the fabrication shop, a field reapplication is not necessary provided original lubrication has not been removed in some manner. For situations where fabrication shop lubricant is in question, field application of bees wax, stick wax, or some other dry lubrication shall be required. Rotational-Capacity requires the test to be conducted with fasteners in the same condition as they will be during installation.
 - b. A WORD OF CAUTION:
 - (i) Lubrication is required to minimize galling during installation. Since nuts are lubricated (both threads and faces), it is important that nuts be rotated during tightening.
 - (ii) Fasteners (bolts and nuts of any type) shall not be tightened, then removed, reinstalled, and retightened.
- 5. Shear Connectors
 - a. Girders generally arrive on-site with all the shear connectors shop welded.
 - b. Shear connectors may either be shop welded or field welded.
 - (i) If they are field welded then the inspector needs to realize that welding shear connectors is a critical operation. The bridge may fail if the shear connectors are not welded properly. Contact NDOT Steel Fabrication Manager prior to any field welding.
 - (ii) Use a "big" hammer to check field welded shear connectors.















**Table 708.01
Shear Connector Checklist**





1.	An arc shield (ferrule) of heat-resistant ceramic or other suitable shall be furnished with each stud. The material shall not be detrimental to the welds or cause excessive slag and shall have sufficient strength so as not to crumble or break due to thermal or structural shock before the weld is completed.
2.	Only approved studs shall be used. The arc shield used in production shall be the same as used in qualification tests.
3.	Before installation of the studs, the contractor shall submit to the inspector for approval information on the studs to be furnished as follows:
a.	The name of the manufacturer.
b.	A detailed description of the stud and arc shield.
c.	Mill certification from the manufacturer that the stud is qualified as specified in the contract.
d.	A copy of the qualification test report as certified by the testing laboratory.
4.	The studs, after welding, shall be free from any defect or substance which would interfere with their function.
5.	Studs shall be end welded to steel with automatically timed stud welding equipment connected to a suitable power source.
6.	If two or more stud welding guns are to be operated from the same power source, they shall be interlocked so that only one gun can operate at a time and so the power source has fully recovered from making one weld before another weld is started.
7.	At the time of welding studs shall be free from any rust, rust pits, scale, oil or other deleterious matter which would affect the welding operation.
8.	Welding shall not be done when the base metal temperature is below 0 degrees or when the surface is wet or exposed to rain or snow.
9.	When necessary to obtain satisfactory welds, the areas on the beam or girder to which the studs are to be welded shall be brushed or ground free of mill scale or rust.
10.	The arc shields or ferrules shall be kept dry. Any arc shield which shows signs of surface moisture from dew or rain shall be oven-dried at 250 degrees for two hours before use.
11.	The first two studs welded on each beam or girder, after being allowed to cool to a temperature of 150 degrees or less, shall be bent 30 degrees by either striking the studs on the head with a hammer or placing a pipe or other suitable hollow device over the stud and manually or mechanically bending the stud.
12.	When the temperature of the base metal is below 32 degrees, tow studs in each 100 studs welded, shall be bent in addition to the first two bent as specified in paragraph 11 above.
13.	Studs on which a full 360 degree weld is not obtained shall be repaired by adding a 3/16 inch fillet weld in place of the lack of weld as long as the repair weld extends 3/8 of an inch beyond the area on each end of where the lack of weld was. The shielded metal-arc process with E7018 or E8018-C3 low hydrogen electrodes shall be used.
14.	Longitudinal and lateral spacing of studs with respect to each other and to edges of the beam or girder flanges may vary a maximum of one inch from the location shown on the drawings. The clear distance between the studs shall not be less than one inch unless approved by the engineer. The minimum distance from the edge of the stud base to the edge of the flange shall be the diameter of the stud plus 1/8 inch, but preferably not less than 1-1/2 inch.
15.	Prequalification. Studs which are field applied in the flat (down hand) position to a planar and horizontal surface are deemed prequalified by virtue of the manufacturer's stud-base qualification tests and no further application testing is required. The limit of flat position is defined as 0-15 degree slope on the surface to which the stud is applied.







Table 708.02
Shear Connector Welder Qualifications

1.	Before any production studs are welded by an operator, they must first shoot two studs on a piece of material similar to the production member in thickness and properties. If the actual thickness is not available, the thickness may vary plus or minus 25%. All test studs shall be welded in the same general position as required on the production member.
2.	The test studs shall be visually examined. They shall exhibit a full 360-degree flash.
3.	In addition to the visual examination, the test shall consist of bending the studs after they are allowed to cool, to an angle of approximately 30 degrees from their original axes by either striking the studs on the head with a hammer or placing a pipe or other suitable hollow device over the stud and manually or mechanically bending the stud.
4.	If on visual examination the test studs do not exhibit 360 degree flash, or if on testing, failure occurs in the weld zone of either stud, the procedure shall be corrected, and two more studs shall be welded to separate material and tested again.
5.	If either of the second two studs fails, additional welding shall be continued on separate plates until two consecutive studs are tested and found to be satisfactory before any production welding begins.

WELDING SYMBOLS

FILLET	PLUG OR SLOT	SPOT OR PROJECTION	SEAM	GROOVE							BACK OR BACKING	SUR-FACING	FLANGE	
				(FLASH OR UPSET) SQUARE	V	BEVEL	U	J	FLARE-V	FLARE BEVEL			EDGE	CORNER
														

ARC-SEAM OR ARC-SPOT	RESISTANCE SPOT	PROJECTION	RESISTANCE SEAM	FLASH OR UPSET
				

WELD ALL AROUND	FIELD WELD	MELT-THRU	CONTOUR		
			FLUSH	CONVEX	CONCAVE
					

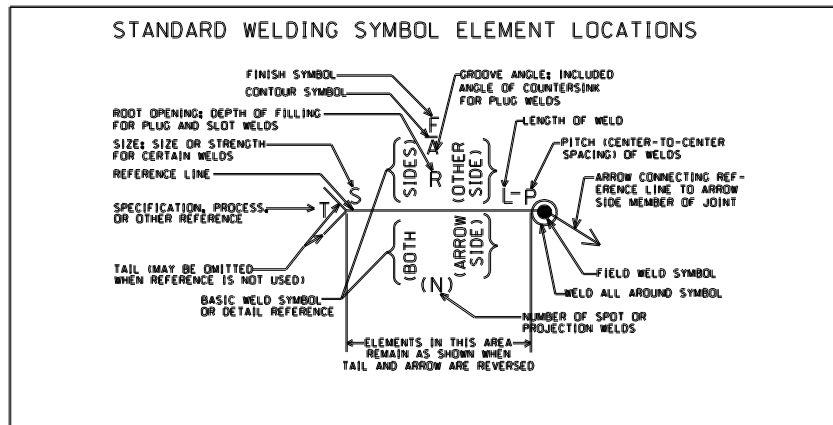

g:\weld1.dgn Jan 30, 1998 10:11:15

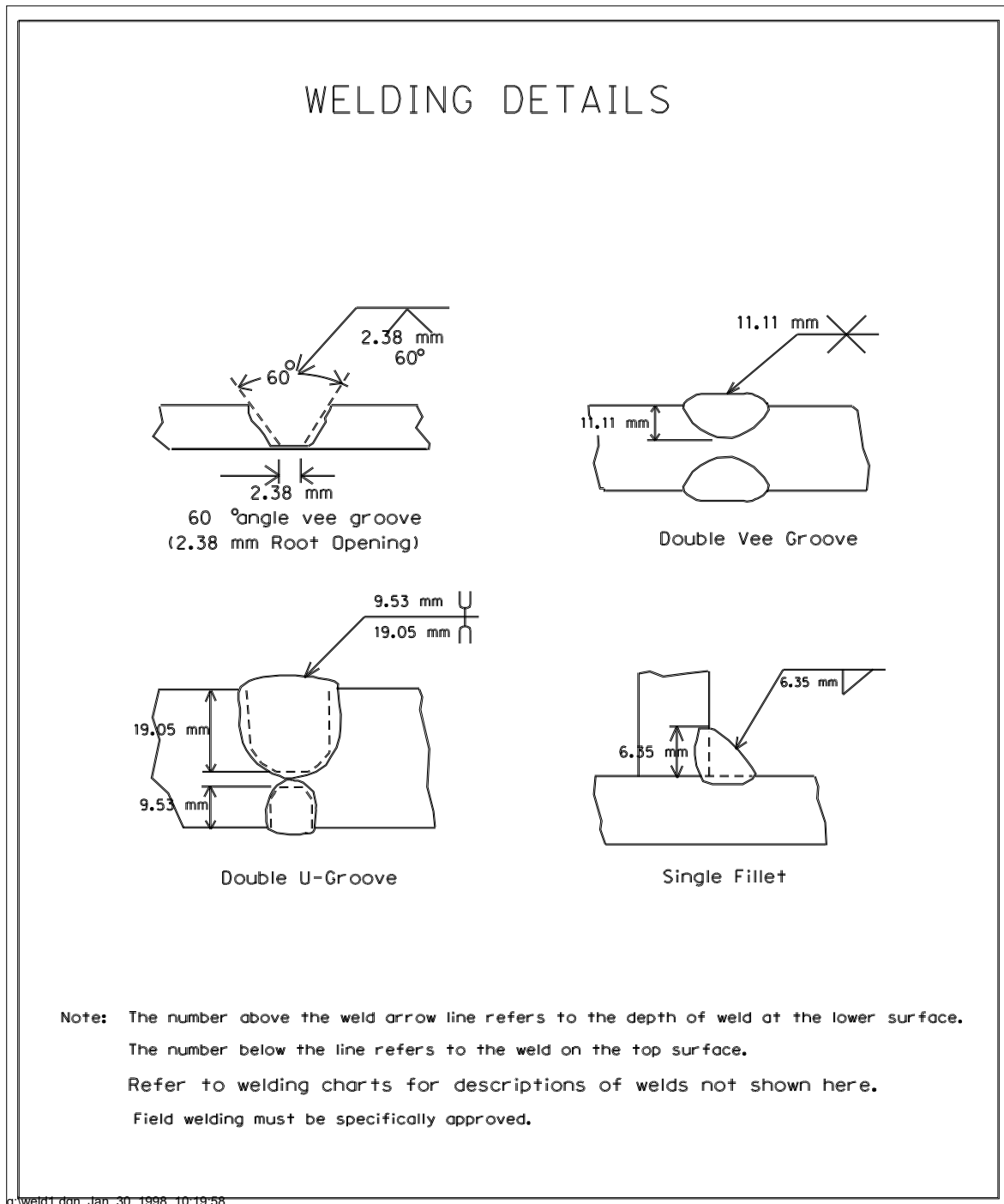

6. Trouble Shooting

- a. Many operating variables can affect the quality and appearance of the weld. Methods for correcting undesirable characteristics are discussed in the following paragraphs. If you encounter any issues in welding – Contact NDOT Steel Fabrication Manager.

7. Weld Spatter
 - a. Spatter does not affect weld strength but does produce a poor appearance and increases cleaning costs.
 - (i) Be sure to control excessive splatter. Try lowering the current. Be sure the current is within the recommended range for the and size electrode (see attached Table).
 - (ii) Be sure the polarity is correct for the electrode type.
 - (iii) Try a shorter arc length.
 - (iv) If the molten metal is running in front of the arc, change the electrode angle.
 - (v) Watch for arc blow.
 - (vi) The electrode is not too wet.
8. Undercut
 - a. Generally, the only harm from undercutting is impaired appearance. However, undercutting may also impair weld strength, particularly when the weld is loaded in tension or subjected to fatigue. To minimize undercut:
 - (i) Reduce current, travel speed, or electrode size until the puddle is manageable.
 - (ii) Change electrode angle so the arc force holds the metal in the corners. Use a uniform travel speed and avoid excessive weaving.
9. Rough Welding
 - a. If polarity and current are within the electrode manufacturer's recommendations but the arc action is rough and erratic, the electrodes may be wet. Try electrodes from a fresh container. It's mandatory to store opened containers of electrodes in a heated ovens. All material shall be free of rust, paint, dirt, oil and any other containments prior to welding.
10. Porosity and Surface Holes
 - a. Most porosity is not visible. But severe porosity can weaken the weld. The following practices minimize porosity:
 - (i) Remove scale, rust, paint, moisture, or dirt from the joint.
 - (ii) Keep the puddle molten for a long time, so that gases may boil out before the metal freezes.
 - (iii) Steels very low in carbon or manganese or those high in sulfur or phosphorus should be welded with a low-hydrogen electrode. Minimize admixture of base metal with weld metal by using low currents and fast travel speeds for less penetration.
 - (iv) Try using a short arc length; short arcs are required for low-hydrogen electrodes.
 - b. Surface holes can be avoided by many of the practices used to minimize porosity.

11. Poor Fusion
 - a. Proper fusion exists when the weld bonds to both walls of the joint and forms a solid bead across the joint. Lack of fusion is often visible and must be avoided for a sound weld. To correct poor fusion:
 - (i) Try a higher current and a stringer-bead technique.
 - (ii) Be sure the edges of the joint are clean.
12. Shallow Penetration
 - a. Penetration refers to the depth the weld enters into the base metal. For full-strength welds, penetration to the bottom of the joint is required. To overcome shallow penetration:
 - (i) Try higher currents or slower travel.
 - (ii) Use small electrodes to reach into deep, narrow grooves.
 - (iii) Allow some gap (free space) at the bottom of the joint.
13. Cracking
 - a. Many different types of cracks may occur throughout a weld. Some are visible and some are not. However, all cracks are potentially serious, because they can lead to complete failure of the weld. The following suggestions may help control potential cracking.
 - b. Most cracking is attributed to high-carbon or alloy content or high-sulfur content in the base metal. To control this type of cracking:
 - (i) Use low-hydrogen electrodes.
 - (ii) Preheat. Use high preheat for heavier plate and rigid joints.
 - (iii) Reduce penetration by using low currents and small diameter electrodes. This reduces the amount of alloy added to the weld from melted base metal.
 - (iv) To control crater cracking, fill each crater before breaking the arc. Use a back-stepping technique so as to end each weld on the crater of the previous weld and the blending the starts and stops.
 - c. On multiple-pass or fillet welds, be sure the first bead is of sufficient size and of flat or convex shape to resist cracking until the later beads can be added for support. To increase bead size, use slower travel speed, a short arc, or weld 5° uphill. Always continue welding while the plate is hot.
 - d. Rigid parts are more prone to cracking. If possible, weld toward the unrestrained ends. Leave a 1/32 inch (0.8 mm) gap between plates for free shrinkage movement as the weld cools. Peen each bead while is still hot to relieve stresses.

708.04 METHOD OF MEASUREMENT

1. Structural steel is usually measured by the pound (kg). Structural steel for handrail is also measured by the pound. Ornamental handrails are measured by the lineal feet of rail between end posts. These values are listed on the plans and may be used in the final computation for payment.

708.05 BASIS OF PAYMENT

1. PMs are authorized to pay for steel plates and shapes as soon as the material arrives at the fabricator.
2. The Nebraska Department of Transportation had determined that it may be possible to improve inspection procedures and to lower construction costs on bridges and other structures where significant quantities of steel are required if stockpiled materials are paid for upon receipt by the fabricator. Therefore, the Department will allow partial payments for stockpiled steel plates and shapes prior to fabrication. The procedure that must be followed before partial payment will be made is as follows:
 - a. The prime contractor must request partial payment from the Department's Project Manager for the specific project where payment is requested.
 - b. The Bridge Divisions, Fabrication Manager [(402)-479-4763] will be responsible for verifying fabricators' invoices and forwarding them to the project managers; for verifying manufacturer's Certified Mill Test Report and forwarding copies to the PM and M&R Division; and for inspection of the steel.
 - c. The fabricator must provide the Department's Fabrication Manager the steel manufacturer's billing invoice for the material. The Project Manager will make the payment for the amount shown on the invoice, which directly is attributed to the project for which payment is being considered. The invoice should be annotated to show:
 - (i) the project number
 - (ii) steel quantity in pounds applicable to the project
 - (iii) material grade
 - (iv) material heat number
 - d. There must be identifying marks placed on each piece for which payment will be made.
 - e. Steel must be stored in orderly fashion to readily facilitate identification of specific materials to specific projects. Project materials cannot be commingled with other projects – each project's materials must have a separate location.
 - f. The Manufacturer's Certified Mill Test Reports must be provided to and approved by the Bridge Division before payment will be authorized. The Bridge Division will notify the Project Manager and Construction Division when payment is authorized.
 - g. The Department will verify that the material is properly stored before payment will be made.

709.00 PAINTING

709.01 DESCRIPTION

1. The painting of metal structures has a dual purpose. The primary function of paint application is to preserve the life of the metal. A second function, especially important in highway grade separations, is to produce and maintain an improved

appearance. Painting includes the preparation of the surface and the application of the paint coatings.

2. For questions regarding bridge painting – Contact Bridge Division Coating Engineer.
3. Painting (*SSHC Section 709*)
 - a. New Non-Weathering Structural Steel (current Bridge Policy is to always use weathering steel on new structures)
 - (i) Shop applied paint system shall be used for non-weathering steel bridges.
 - (ii) A field applied "top coat" is usually required. A top coat will also be required when it is deemed necessary due to aesthetics.
 - (iii) The contractor will be required to touch-up any damaged areas after erection. Touch-up with top coat paint system shall be the same paint as the shop coat.
 - b. New Weathering (ASTM A 588) Structural Steel
 - (i) The plans require shop applied prime paint to selected areas on the structure. They also require:
 - (ii) The approved paint system.
 - (iii) Only paint where shown in the plans with approved paint system.
 - (iv) The contractor to touch-up any damage to primed areas after erection prior to top coating. This includes bolts in those areas. Touch-up paint shall be the same paint as the shop coat.
 - c. Field Painting
 - (i) Field painting of structural steel shall be done as shown in the plans and special provisions.

709.02 MATERIAL REQUIREMENTS

1. Paint shall be the system specified in the special provisions and accompanied by the manufacture's certification of compliance in accordance with the [Materials Sampling Guide](#).
 - a. Mixing Paint
 - (i) Follow the manufacturers recommended mixing and thinning procedures.

709.03 CONSTRUCTION METHODS

1. Painting Structural Steel
 - a. Paint which has been applied on rust, or dirty surfaces will peel and crack. If rust blisters form under the paint film, they can, in time, seriously reduce the effective cross section of structural shapes. The specifications require that all erection work be completed before the cleaning process is started. The cleaning should be done in a systematic manner, with the painters cleaning a given area or member before painting it.

- b. Paint shall be applied as prescribed by contract specifications or the manufacturer's recommendations, whichever is most restrictive. The Project Manager shall determine the correct procedure if the contract specifications differ from the manufacturer's recommendations.
- c. The Project Manager or inspector should insist that the painting be done systematically, with painters working in groups on a given coat. The practice of having cleaners and painters spread out all over a bridge, with the inspector not knowing what men are working on each operation, nor which members have been cleaned and painted, should not be permitted. Painting should, in general, be started with the highest bridge members and progress downward, in order to cover areas where paint has dripped from the work above. Painting operations below deck level, should be permitted only after the deck slab concrete has been placed. Girders painted prior to the concrete placement are likely to be spattered by form leakage and may be badly scarred by form removal, necessitating considerable re-cleaning and repainting of all coats.
- d. The plans and specifications require different paint film thickness depending on the type of paint specified. The Project Manager should check the plans and specifications to determine the types of paint required to verify that the correct system has been certified and should check for the required dry film thickness.
- e. The Project Manager or inspector should check the dry film thickness of the shop and field coats of paint applied on structural steel in accordance with the following instructions:
- f. Shop Coat - The shop coat of paint may or may not have been checked in the fabricator's shop; nevertheless the shop coat should always be checked in the field, and any deficiency in paint film thickness corrected, before the next coat is started. When the dry film thickness of the shop coat is found to be inadequate, the Construction Division Structures and Grading unit should be notified in order that the particular fabricator involved may be made aware of the situation.
- g. Second and Third Coats - Checking the thickness of the second and third coat with the magnetic gauge is accomplished by measuring the cumulative thickness of the first (or shop coat) and the additional coats. The dry film thickness of the second coat should always be checked and any deficiency in paint film thickness corrected before the third coat is started. Any deficiency in paint film thickness must be corrected before the work can be considered complete and consideration of acceptance given.

- h. The equipment used to check the dry film paint thickness is called a dry film thickness gauge. Each District Office has one or two for use in the District in checking the painting of steel structures. M&R Physical Test Lab has one available for use. These gauges are expensive, delicate instruments and must be carefully handled and always kept in the carrying case when not in use. The procedure for using the magnetic version of the gauge is as follows (digital versions are also available and preferred):

 - (i) Turn dial to maximum reading.
 - (ii) Place pole on the surface to be measured.
 - (iii) Be sure the magnetic contact is touching the painted surface.
 - (iv) Slowly and as continuously as possible, rotate the dial clockwise until magnetic contact breaks. A click will be heard when the pin breaks contact. At this point the coating thickness can be read on the dial indicator. The reading will remain on the dial when the gauge is removed from the surface being checked. The gauge can also be held in any position to take a reading. The magnetic gauge reads directly in mils. A reading of 2 on the dial indicates that the thickness of the paint film is 2 mils or .002 inch.
- i. The frequency of testing for paint thickness should be as follows:

 - (i) Girders - Each line of girders should be checked at a maximum interval of 50 ft (15 m) and at each check point, 3 or 4 tests should be made. For example, on a 200 ft (60 m) bridge each line of girders should be checked at the abutments and at 3 intermediate points. At each one of these points three or four places should be checked such as a point on the web, a point on each flange, and a point on a stiffener. This is in accordance with SSPC PA2
 - (ii) Separators, Cross-frames and Floor Beams - Alternate lines of separators, cross-frames and floor beams should be checked two times at one location. For example, the top and bottom angle should both be checked for every other line of cross-frames.
 - (iii) Lateral Bracing - Lateral bracing should be checked at about 50 foot intervals.
 - (iv) Miscellaneous Material - Material such as expansion devices, tie rods, bearing plates and drainage systems should be spot checked for required paint film thickness.
- j. Additional tests should be made, as required, to determine the extent and location of any areas deficient in paint film thickness.
- k. The DWR should verify that the paint film thickness on each structure meets the thickness requirement specified, and the entry should include the date of inspection.

709.04 METHOD OF MEASUREMENT

709.05 BASIS OF PAYMENT

710.00 CONCRETE BRIDGE DECK REPAIR WITH SILICA FUME CONCRETE

711.00 CONCRETE BRIDGE DECK REPAIR AND OVERLAY

**710.01 &
711.01 DESCRIPTION**

1. The concrete bridge floor is the wearing surface of the bridge superstructure and is commonly referred to as the bridge "deck". This work consist of removing delaminated concrete and overlaying the bridge deck with a concrete overlay. This is applicable for both Silica Fume and 47B-OL overlays.

<i>SSHC References:</i>	<i>Section 711</i>	<i>Concrete Bridge Deck Repair and Overlay</i>
	<i>Section 1002</i>	<i>Portland Cement Concrete</i>
	<i>Section 1010</i>	<i>White Opaque Polyethylene Film and White Burlap—Polyethylene Sheeting For Curing Concrete</i>
	<i>Section 1011</i>	<i>Burlap For Curing Concrete</i>
	<i>Section 1014</i>	<i>Joint Sealing Filler</i>
	<i>Section 1015</i>	<i>Preformed Joint Filler</i>
	<i>Section 1016</i>	<i>Preformed Polychloroprene Elastomeric Joint Seals</i>
	<i>Section 1033</i>	<i>Aggregates</i>

Inspection Crew: Placement Inspector

Inspection Equipment:

- Slump Cone
- Air Meter (pressure)
- Cylinder Molds and Lids
- Rod
- Mallet
- Strike Off Bar
- Ruler
- 10 ft (3 m) straightedge
- Anemometer
- Thermometer
- Hygrometer

Placement Procedures:

1. Preplacement check of equipment.
2. Check condition and placement of steel.
3. Check Form setting and alignment.
4. Check deck for cleanliness.

5. Have contractor wet deck and forms before concrete placement.
6. Test concrete for air content and make cylinders when mix changes, as a minimum according to [Materials Sampling Guide](#).
7. Watch concrete placement for compliance with specifications.
8. Do not use water as a finishing aid; use an approved chemical finishing aid/evaporation retardant.
9. Check surface with straightedge. Remove depressions and irregularities.
10. Check tining for conformance to specification.
11. Check cure operation.

Construction Critical Area:

1. Check finish machine (template & rails).
2. Check repair areas.
3. Deck shall be uniformly wet, without puddles prior to placement.
4. Maintain a uniform roll, of about 4 inches (100 mm), of concrete ahead of the front screed and a minimum of a 2 inch (50 mm) roll ahead of the rear screed.
5. The time between loads of concrete.
6. Trucks that segregate concrete or have cement balls must not be used.
7. Avoiding placement when temperatures and wind velocities may cause plastic shrinkage cracking (see SSHC Figure 711.01).
8. Fogging system, when used, should be operating from time concrete is finished until wet burlap is in place.
9. Check tining operation.
10. The timing of wet burlap application.

Safety Areas:

NDOT Tests:

1. ASTM C 31 Making and Curing concrete test specimens.
2. ASTM C 143/C 143M Slump of Portland Cement Concrete.
3. ASTM C 172 Sampling of Fresh Concrete.
4. ASTM C 231 Air Content of Freshly Mixed Concrete by the Pressure Method.

711.02 MATERIAL REQUIREMENTS

1. See Subsection 706.02

711.03 EQUIPMENT

1. Jackhammers greater than the 60 lb class shall not be used. As the contractor gets close to the limits of repair areas, small chipping hammers (15 lb class) should be used to limit damage to the adjacent concrete.
2. Chipping hammers greater than 30 lb class not be used below the top mat of steel.
3. Hydroblasting – Hydroblasting is not currently in our specifications, however, contractors can request approval from Engineer to use it. Contact Construction Division for guidance

711.04 CONSTRUCTION METHODS

1. General – The wind velocity-temperature relationships stated in the specifications should be enforced to avoid loss of water from the concrete surface faster than it can be replaced by normal bleeding and to avoid the resultant formation of plastic shrinkage cracks. Anemometers and thermometers must be available on site to measure wind velocity and temperature.
 - a. Concrete in bridge floors shall be placed uniformly on both sides of the centerline and shall be placed continuously between specified joints. The sequence of placing shall be in accordance with the pouring diagram shown in the plans. If no pouring diagram is shown in the plans, concrete shall be placed as directed by the Project Manager.
 - b. The deck forms shall be d wet before placing the concrete. Concrete shall be adequately vibrated to encase the lower bars of the reinforcing mat where these are near the deck form.
 - c. Special attention shall be given to finishing the riding surface on the bridge floors. *SSHC* Subsections 706.03, and 711.03 explain concrete bridge floor finish.
 - d. Mechanical finishing machines of an approved type are required by the contract.
 - e. The longitudinal float shall be lapped 1/2 its length when moved to a new position and shall be operated across the surface a sufficient number of times to produce a uniform, smooth riding surface. Occasionally during the finishing operation, conditions may require the use of the long-handled transverse float, which require extreme care in its use to preserve the desired cross-section and a smooth riding surface.
 - f. The floor surface shall be tested for trueness with a 10 ft (3 m) straightedge. The bridge contractor is required to furnish a 10 ft (3 m) master straightedge for use in trueing and checking the working straightedges.
 - g. Phased construction of a bridge deck usually requires a form longitudinally down the bridge deck near the center of the bridge. The location of the form is shown in the plans. Sometimes it is more efficient to move the location of the longitudinal phasing joint. On bridges with concrete girders it is nice if the joint can be lined up to use the notched lip in the girder flange. However, the resulting lane widths must be checked to confirm there is adequate clearance for vehicles.

2. Bridge Deck Curing
 - a. When the high temperature for the day that the deck will be cast is expected to exceed 77°F the deck should be cast at night. The Contractor should contact the concrete plant and schedule the concrete deliveries to the bridge deck to begin in the evening. The Contractor must also confirm that the concrete will have a 1-hour set delay when it arrives on the deck.
3. Deck Overlay Preparation
 - a. Securing an adequate bond at the interface of the existing prepared deck surface and proposed overlay course is essential in obtaining a durable and maintenance free bridge deck system. General surface preparation requires milling, chipping, shotblasting, and/or sandblasting depending on the surface condition or amount of existing surface material to be removed. Any reinforcing bar which is exposed must be sandblasted to remove all rust contaminants, and unsound concrete. Also, prior to placing the overlay the surface must receive an air blast to remove dust and other foreign particles from the prepared surface.
 - b. The surface, once cleaned, must remain clean until the concrete is placed. There have been cases where the prepared deck surface has become contaminated during the decking operations by concentrated traffic of vehicles transporting the concrete. This is especially true when the skid-steer type loaders are used to transport mix. The deck surface is contaminated by the abrasive action between the concrete surface and the rubber tires, and also from oil and other foreign material tracked in from off the bridge. Contamination can be recognized by discoloration or oil on the deck surface. Contamination is especially noticeable in the wheel paths used by the vehicles.
4. Core specimens taken and tested for bond strength from areas as mentioned above showed a marked decrease in bond strength between the interfaces.
 - a. To prevent the cleaned deck surface from being contaminated by traffic, the contractor shall cover any prepared surface with sheets of plywood, multiple layers of plastic, or other suitable material. To ensure a clean surface prior to placement of the overlay system, areas which become contaminated shall be resandblasted followed by an air blast.
 - b. The prepared bridge deck shall be in a surface saturated dry (SSD) condition prior to placing the overlay. SSD is achieved by thoroughly wetting the surface 2 hour prior to the placement. All standing water shall be removed from the surface prior to overlay placement.
 - (i) Grouting of the bridge deck is no longer allowed because of the risk of the grout drying out and creating a bond breaker.
5. Class I Floor Repair (*SSHC Section 711*)
 - a. Follow guidance in *SSHC Subsection 711.04*, para. 1.
6. Work on Adjacent Lanes
 - a. *SSHC Section 422* prescribes traffic provisions when traffic is present.

**710.05 &
711.05**

METHOD OF MEASUREMENT

- 710.06 &
711.06 BASIS OF PAYMENT**
- 712.00 FIXED BEARINGS AND EXPANSION BEARINGS, TFE TYPE**
- 712.01 DESCRIPTION**
- 712.02 MATERIAL REQUIREMENTS**
- 712.03 CONSTRUCTION METHODS**
- 712.04 METHOD OF MEASUREMENT**
- 712.05 BASIS OF PAYMENT**
- 713.00 CONFINED ELASTOMERIC BEARING DEVICES (POT BEARINGS)**
- 713.01 DESCRIPTION**
 - 1. The Materials and Research Division inspects pot bearings at the site. In order to facilitate the work, we request that the Materials and Research Division be notified immediately when the pot bearings arrive at the site. This will permit Materials and Research personnel to inspect the bearings in a timely manner.
- 713.02 MATERIAL REQUIREMENTS**
- 713.03 CONSTRUCTION METHODS**
- 713.04 METHOD OF MEASUREMENT**
- 713.05 BASIS OF PAYMENT**
- 714.00 MECHANICALLY STABILIZED EARTH (MSE) WALLS WITH CONCRETE FACING PANELS**
- 714.01 DESCRIPTION**
- 714.02 MATERIAL REQUIREMENTS**
- 714.03 CONSTRUCTION METHODS**
- 714.04 METHOD OF MEASUREMENT**
- 714.05 BASIS OF PAYMENT**
- 715.00 MECHANICALLY STABILIZED EARTH (MSE) WALLS WITH MODULAR BLOCK FACING UNITS**
- 715.01 DESCRIPTION**
- 715.02 MATERIAL REQUIREMENTS**
- 715.03 CONSTRUCTION METHODS**
- 715.04 METHOD OF MEASUREMENT**
- 715.05 BASIS OF PAYMENT**
- 716.00 STEEL RAILINGS**
- 716.01 DESCRIPTION**
 - 1. This work shall consist of furnishing and erecting all steel or ornamental handrail and all miscellaneous hardware such as anchor bolts, capacity plates, and splices.

716.02 MATERIAL REQUIREMENTS

1. Handrails shall conform to the horizontal and vertical curves specified in the plans. Posts shall be set normal to the top of the curb, except when otherwise noted in the plans or special provisions.

716.03 CONSTRUCTION METHODS

1. Ornamental Handrail
 - a. Care must be taken in storing, handling, and erecting ornamental handrail so as not to permanently mar or injure the finish on the post and rail elements. Aluminum ornamental handrail which is to be stored in the open should be removed from the cardboard cartons since cartons may stain the handrail when they become wet and considerable effort is required to remove these stains.
 - b. Ornamental handrail inspection is not generally waived at the fabrication plant even if small quantities are involved. If the Project Manager does not have a copy of a shop inspection report on file indicating inspected material, the material should be inspected by Materials and Research Division. If there is a question of whether the material has been inspected or not, the Materials and Research Division should be contacted for clarification.
 - c. The Project Manager should make a visual check of the handrail before placing it in the structure. In the case of aluminum tubing, "carbon streaks" that develop in the manufacturing process are not cause for rejection. However, the carbon streaks should be limited to one 90-degree segment of the surface of any rail. Particular attention is necessary at the time of erection. Tubing should be placed in the bridge railing in such a manner that the carbon streaks are not visible to traffic.

716.04 METHOD OF MEASUREMENT

716.05 BASIS OF PAYMENT

717.00 CONCRETE BOX CULVERTS

717.01 DESCRIPTION

1. A culvert may be defined as a structure to convey water under a roadway. Concrete box or arch culverts are used when drainage areas are too large for the conventional culvert pipe or when cattle passes under the roadway are desired. These structures are cast-in-place according to standard or special plans under *SSHC Sections 702, 704, 705 and 717.*

717.02 MATERIAL REQUIREMENTS

1. See Section 704.02. Note in SiteManager the date the reinforcing steel is verified on-site.

717.03 CONSTRUCTION METHODS

1. General - The concrete placement for box and arch culverts is discussed in Section 704 of this manual. *SSHC Subsection 717.04* further provides that foundation excavations shall be "as dry as practicable before concrete is poured". This requirement recognizes the necessity of an adequate foundation for roadway structures. When the excavation for a footing is completed, the

project manager or their representative should be contacted for their approval of the footing subgrade before any concrete is placed. In the event that unsuitable foundation subgrades are encountered, suitable ones composed of sand, gravel, crushed concrete, or concrete aggregates (see *SSHC Subsections 702*).

- a. Construction of curtain walls on culvert footings usually is quite a problem because of the difficulty in maintaining the excavation in proper condition while placing concrete.
 - b. If material to be excavated is of such nature that neat lines for the curtain wall cannot be maintained, the Project Manager may allow an optional construction joint between box and curtain wall as shown in plans.
 - c. Mud must be prevented from working up into the concrete.
2. Form and Falsework Removal
 - a. See Section 704.
 3. Placing Concrete
 - a. Placing Concrete in Walls and Top Slab. *SSHC Subsection 704.03* states that culvert, sidewalls, and top of slab may be constructed as:
 - (i) A monolith unit or,
 - (ii) Concrete in sidewalls may be placed and allowed to harden before the top slab is placed.
 4. Sheet Pile Turndown. Option to Use Steel Sheet Piling in Lieu of the Planned Turndowns at Box Culvert Ends (See plans).

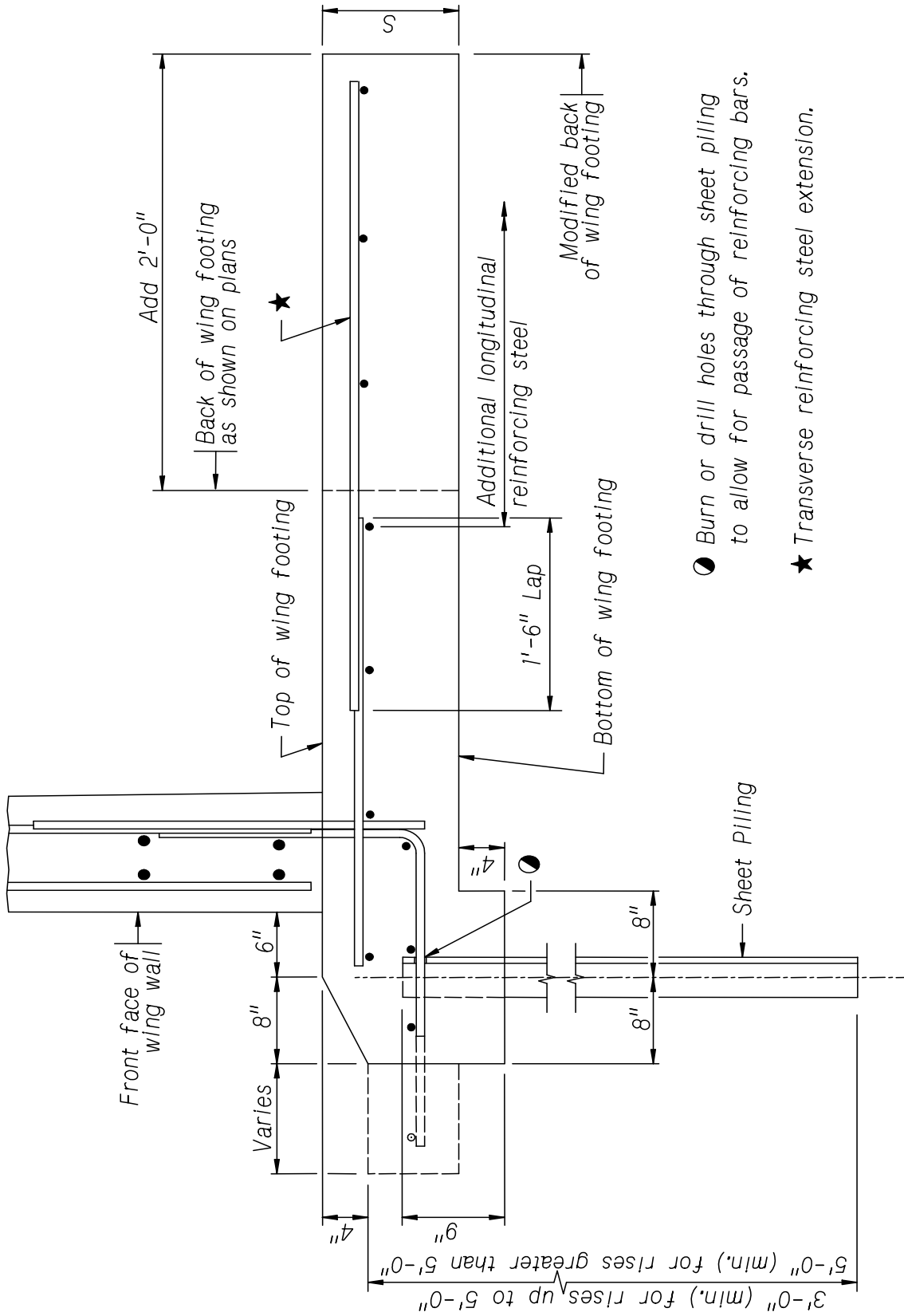

● Burn or drill holes through sheet piling to allow for passage of reinforcing bars.

★ Transverse reinforcing steel extension.

OPTIONAL SHEET PILING TURNDOWN AT WING FOOTING

(For concrete box culvert wings)

5. Removal of Wall Forms
 - a. On large culvert jobs, it is a distinct advantage for the contractor to remove wall forms before the top slab has attained sufficient age to remove supporting forms. This will be permitted under the following conditions:
 - (i) Vertical forms may be removed as provided in *SSHC Subsection 704.03*.
 - (ii) Slab forms must be supported independently of the wall forms.
 - (iii) The slab form must remain in place as provided in *SSHC Subsection 704.03*.
 - (iv) The interior walls of the culvert must be coated with white pigmented curing compound as provided in *SSHC Subsection 704.03* (if stripped in less than 72 hours)
6. Flume Reinforcement
 - a. Regarding Type I, II, IV, and V Flumes, welded wire fabric reinforcing is now required on the Special Plan C (4341, 4342, 4344, 4345 – both E & M) for the flume and spillway areas. This wire can be awkward to place and keep in position. Contractors may place **intersecting No. 3 rebar at 12” centers** as an alternative to the welded wire fabric.
7. Backfilling Culverts – Typical Grading
 - a. The plans define the area used to calculate plan quantities for flowable mortar and granular backfill. (Flowable mortar plan quantities should include 30% additional for anticipated consolidation of the granular backfill and shrink due to loss of water.) If the Contractor opts to excavate a larger area than assumed for plan quantity, additional excavation, backfill, and flowable mortar will not be considered for pay. We will however, require additional excavation to be backfilled in a manner as identified by the plans or typicals.
 - b. Placement of flowable mortar shall always be computed from "top down." This means allow for:
 - (i) Pavement thickness.
 - (ii) 1 foot (0.3 m) of special backfill, if required.
 - (iii) Variable thickness of earth fill where cover heights are over 8 ft (2.5 m).
8. Joints (*SSHC Subsection 704.03*)
 - a. The location and dimensions for construction joints will generally be shown on the plans.
 - b. In cases where the pour is larger than can be accomplished at one time, or for some other reason it is necessary to make a construction joint not shown on the plans, approval should come from the Construction Engineer.
 - c. When an emergency arises, construction joints shall be placed as directed by the Project Manager. If there is some doubt as to the proper

location of the joint, the District Construction Engineer should be contacted.

- d. Shear keys, when shown in plans, should be formed with beveled strips or boards at right angles to the direction of shear. Typical dimensions for a shear key are shown in the following sketch.
- e. If the volume of concrete culvert pour is greater than can be placed in a normal day's operation, or in case of emergency, construction joints located in accordance with the details shown in the drawing "Construction Joints for Box Culverts" may be constructed. Construction joints between roadway shoulder lines are not shown in this drawing since they are not to be so constructed unless authorized by the Construction Engineer.
- f. Construction joints in box culverts should be located as follows: Vertical floor joints, wall joints and top slab joints should be constructed in accordance with the sketches in this article and should be staggered by approximately 3 ft (1.0 m). When the walls and top slab are placed simultaneously, the top slab should be stopped and jointed approximately 3 ft (1.0 m) before ending the wall. (Refer to sketch "Construction Joint for Box Culverts".)

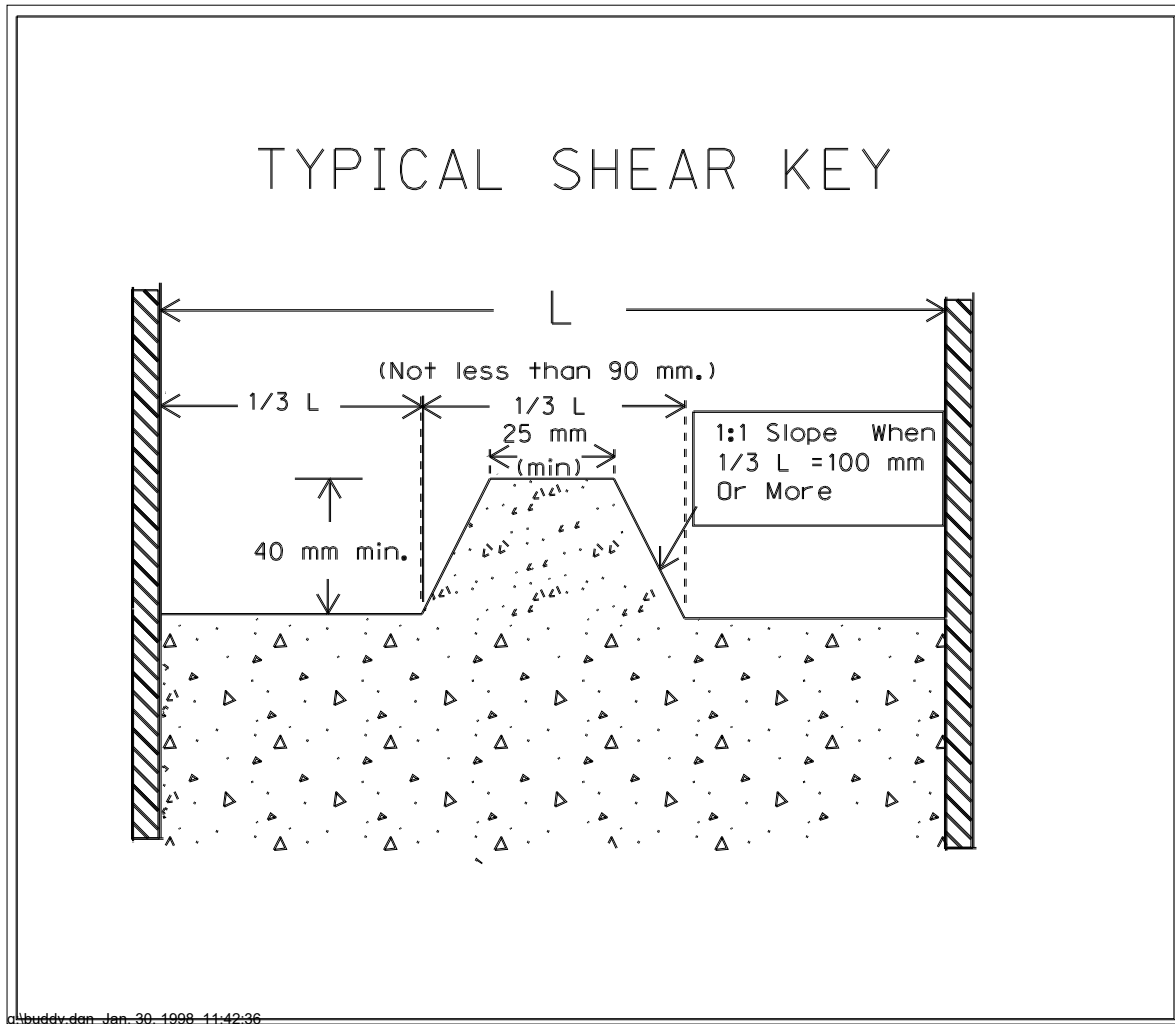

[The side slopes of the key will be less than one to one until the widest dimension of the key reaches 4 inches (100 mm).]

717.04 METHOD OF MEASUREMENT AND BASIS OF PAYMENT

718.00 CULVERT PIPE

718.01 DESCRIPTION

1. This work shall consist of furnishing and installing culvert pipe. The contractor has the option to furnish any of the types of culvert pipe listed in the plans according to the [Pipe Material Policy](#).

718.02 MATERIAL REQUIREMENTS

718.03 CONSTRUCTION METHODS

1. Culvert List. The contractor is not permitted to order or deliver culvert pipe until a "culvert order list" listing the correct sizes and lengths of pipe is furnished to them by the Project Manager.

2. Pipe Bedding

- a. Pipe bedding is explained in the Standard Plan 411, additional information can be found in the Department's "[Pipe Material Policy](#)".
- b. The following soil classifications are necessary to use the pipe standard plans to determine correct bedding materials.

ASTM D 2487 Description and Identification of Soils			
		SIEVE RANGE	
GRAVEL	COURSE	Passes 3-inch	Retained on 3/4-inch
	FINE	Passes 3/4-inch	Retained on No. 4
SAND	COURSE	Passes No. 4	Retained on No. 10
	MEDIUM	Passes No. 10	Retained on No. 40
	FINE	Passes No. 40	Retained on No. 200

3. Temporary Culvert Pipe

- a. The Districts will be responsible for making a determination (presumably during the plan-in-hand inspection) regarding whether or not to ask for new pipe.

4. Salvaged Culvert Pipe.

- a. The following listed examples and rules are given to help clarify removal and salvage of culvert pipe.

b. Rules

- (i) The decision to salvage or not to salvage the culvert pipe at each location must be made by the Inspector or Project Manager prior to beginning removal work on the culvert pipe, and the contractor must be advised of your decision prior to commencing work on the removal.
- (ii) Culvert pipe ordered salvaged and carefully removed by the contractor will be paid for as per the specifications even though after removal it is apparent that the removed pipe has no salvage value.
- (iii) The contractor must carefully remove the culvert pipe to prevent damage to the culvert pipe.

c. Examples

- (i) The contractor is ordered to salvage the culvert pipe. The contractor carefully removes the culvert pipe. The culvert pipe has almost rusted through from the outside and really has no salvage value. The length of pipe removed will be included for payment.
- (ii) The contractor is ordered to salvage the culvert pipe. After the pipe has been uncovered, it is apparent that it has very little salvage value. If the contractor is agreeable, the Inspector or Project Manager can rescind their salvage order and the contractor can complete the removal any way possible. The length

- of pipe removed under these conditions will not be included for payment.
- (iii) The contractor is ordered to salvage the culvert pipe. The contractor is careless in removing the culvert pipe and damages it. The length of pipe removed less the damage length may be included for payment, or the Inspector or Project Manager may determine that there is no salvage value left in the culvert pipe and no payment will be made for salvaging the culvert pipe at this location.
 - (iv) The contractor is ordered to not salvage the culvert pipe. The contractor removes the culvert pipe and disposes of part of it. The contractor advises that the remaining removed pipe may be picked up by the Department. The Department may refuse to pick it up, inasmuch as all such material is the property of the contractor and it is their responsibility to properly dispose of such material. If the Department picks it up the lengths may be included for payment as salvaging culvert pipe or they may be picked up without payment being made. The Inspector or Project Manager shall determine what is fair and just.
- d. Decisions and Documentation
- (i) There will undoubtedly be conditions arising which are not entirely covered by these rules or examples but the Inspector or Project Manager should be able to make the proper decision within the spirit of these guidelines.
- e. The project records must include pertinent notes explaining and detailing decisions made on salvaging culvert pipe.

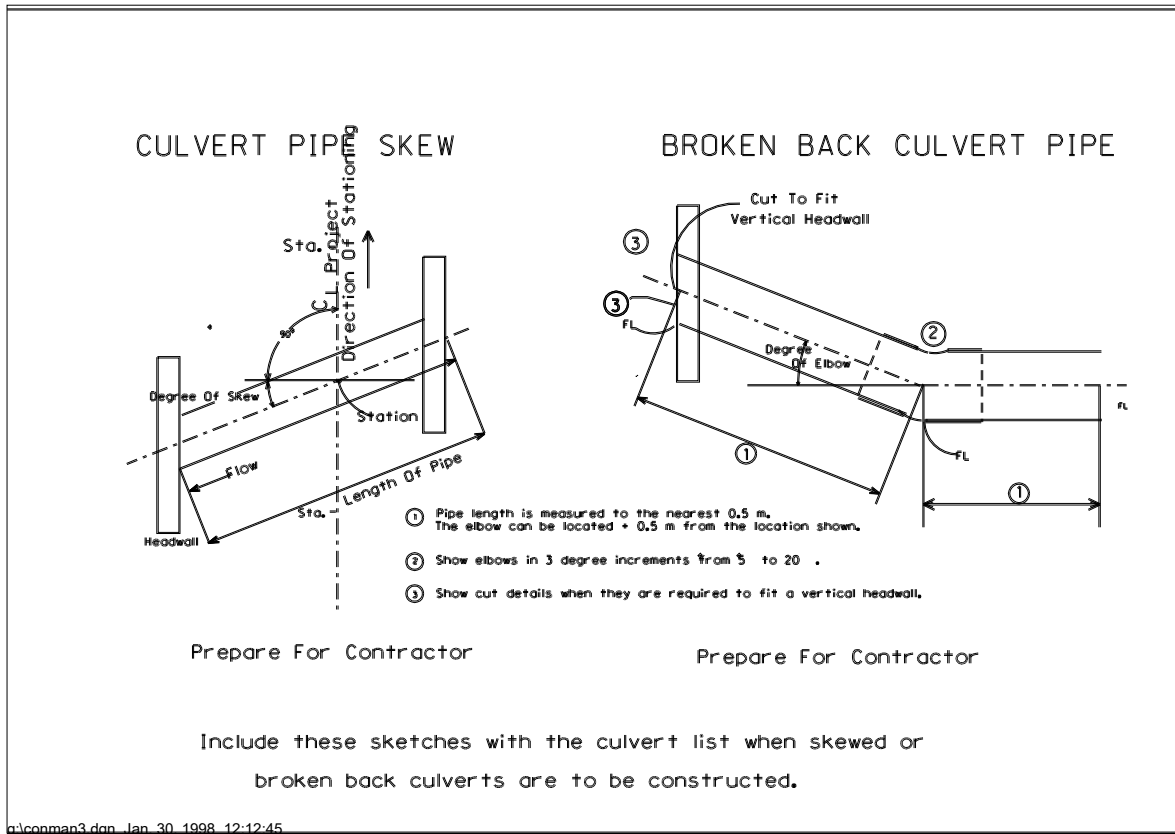

ADDITIONAL EXCAVATION FOR EMBANKMENT OR BACKFILL

The following charts may be used for computing Additional Excavation for Embankment or Backfill for circular culvert pipe, arch culvert pipe or elliptical culvert pipe (pages 450C, D, E, F). "Y" is the distance from natural ground to the center of the pipe or in the case of arch pipe to the widest part of the pipe. The numbers in the columns under the different size pipe diameters are the end area in square feet of the backfill required by the specification.

Example: A 24" circular culvert pipe is laid at Station 17+30 with Flowline Lt. 2416.60 at 47' and Flowline Rt. 2415.00 at 51'. The field design cross-section is 16.6 at 50' Lt., 16.3 at 35' Lt., 16.2 at 18' Lt., 16.2 at CL, 16.0 at 5' Rt., 16.0 at 10' Rt., 15.3 at 15' Rt., 15.0 at 27' Rt., 15.7 at 42' Rt. and 15.5 at 55' Rt.

16.6 at 50'		
16.5 at 47'	FL = 16.6 at 47'	Y = 1.1
16.3 at 35'	FL = 16.4 at 35'	Y = 1.1
16.2 at 18'	FL = 16.1 at 18'	Y = 0.9
16.2 at CL	FL = 15.8 at CL	Y = 0.6
16.0 at 5'	FL = 15.8 at 5'	Y = 0.8
16.0 at 10'	FL = 15.7 at 10'	Y = 0.7
15.3 at 15'	FL = 15.6 at 15'	Y = 1.3
15.0 at 27'	FL = 15.4 at 27'	Y = 1.4
15.7 at 42'	FL = 15.1 at 42'	Y = 0.4
15.6 at 51'		
15.5 at 55'	FL = 15.0 at 51'	Y = 0.4

24"×98' Culvert Pipe

Circular Culvert Pipe Embankment Areas

(Y=Height, TC = Center of Pipe)

Pipe Diagram

Y	12"	15"	18"	24"	30"	36"	42"	48"	54"	60"	72"
0.1	0.4	0.4	0.4	0.4	0.4	0.4	0.4	0.4	0.4	0.4	0.4
0.2	0.9	0.9	0.9	0.9	0.9	0.9	0.9	0.9	0.9	0.9	0.9
0.3	1.4	1.4	1.4	1.4	1.4	1.4	1.4	1.4	1.4	1.4	1.4
0.4	2.0	2.0	1.9	1.9	1.9	1.9	1.9	1.9	1.9	1.9	1.9
0.5	2.6	2.6	2.6	2.5	2.5	2.5	2.5	2.5	2.5	2.5	2.5
0.6	3.3	3.3	3.2	3.2	3.2	3.2	3.2	3.2	3.2	3.1	3.1
0.7	4.1	4.0	4.0	3.9	3.9	3.9	3.8	3.8	3.8	3.8	3.8
0.8	4.9	4.9	4.8	4.7	4.6	4.6	4.6	4.6	4.6	4.5	4.5
0.9	5.7	5.7	5.7	5.5	5.4	5.4	5.4	5.3	5.3	5.3	5.3
1.0	6.6	6.6	6.6	6.4	6.3	6.2	6.2	6.2	6.2	6.1	6.1
1.1	7.5	7.6	7.6	7.4	7.2	7.1	7.1	7.1	7.0	7.0	7.0
1.2	8.5	8.6	8.6	8.5	8.2	8.1	8.0	8.0	7.9	7.9	7.9
1.3	9.5	9.6	9.6	9.4	9.4	9.1	9.0	9.0	8.9	8.9	8.8
1.4	10.5	10.7	10.7	10.7	10.6	10.3	10.1	10.0	10.0	9.9	9.8
1.5	11.6	11.8	11.9	11.9	11.8	11.5	11.2	11.1	11.0	11.0	10.9
1.6	12.7	12.9	13.0	13.1	13.1	12.8	12.5	12.3	12.2	12.1	12.0
1.7	13.9	14.1	14.2	14.4	14.4	14.1	13.7	13.5	13.4	13.3	13.2
1.8	15.1	15.3	15.5	15.7	15.7	15.5	15.2	14.8	14.7	14.5	14.4
1.9	16.3	16.6	16.8	17.0	17.1	17.0	16.7	16.2	16.0	15.8	15.6
2.0	17.6	17.9	18.1	18.4	18.5	18.5	18.2	17.7	17.4	17.2	17.0
2.1	18.9	19.2	19.5	19.8	20.0	20.0	19.8	19.3	18.9	18.6	18.3
2.2	20.3	20.6	20.9	21.3	21.5	21.5	21.4	21.0	20.5	20.1	19.8
2.3	21.7	22.0	22.3	22.8	23.1	23.1	23.0	22.7	22.2	21.7	21.3
2.4	23.1	23.5	23.8	24.3	24.7	24.8	24.7	24.4	24.0	23.4	22.9
2.5	24.6	25.0	25.4	25.9	26.3	26.5	26.4	26.2	25.8	25.2	24.5
2.6	26.1	26.6	26.9	27.5	28.0	28.2	28.2	28.0	27.7	27.1	26.2
2.7	27.7	28.1	28.5	29.2	29.7	29.9	30.0	29.9	29.6	29.1	28.0
2.8	29.3	29.8	30.2	30.9	31.4	31.7	31.9	31.8	31.5	31.1	29.8
2.9	30.9	31.4	31.9	32.6	33.2	33.6	33.8	33.7	33.5	33.1	31.8
3.0	32.6	33.1	33.6	34.4	35.0	35.5	35.7	35.7	35.5	35.2	33.9
3.1	34.3	34.9	35.4	36.2	36.9	37.4	37.7	37.7	37.6	37.3	36.1
3.2	36.1	36.7	37.2	38.1	38.8	39.3	39.7	39.8	39.7	39.5	38.3
3.3	37.9	38.5	39.0	40.0	40.8	41.3	41.7	41.9	41.9	41.7	40.6
3.4	39.7	40.4	40.9	41.9	42.8	43.4	43.8	44.0	44.1	43.9	43.0
3.5	41.6	42.3	42.9	43.9	44.8	45.5	45.9	46.2	46.3	46.2	45.4
3.6	43.5	44.2	44.8	45.9	46.9	47.6	48.1	48.4	48.6	48.5	47.8
3.7	45.5	46.2	46.8	48.0	49.0	49.7	50.3	50.7	50.9	50.9	50.2
3.8	47.5	48.2	48.9	50.1	51.1	51.9	52.6	53.0	53.2	53.3	52.7
3.9	49.5	50.3	51.0	52.2	53.3	54.2	54.9	55.3	55.6	55.7	55.3
4.0	51.6	52.4	53.1	54.4	55.5	56.5	57.2	57.7	58.0	58.2	57.9
4.1	53.7	54.5	55.3	56.6	57.8	58.8	59.6	60.1	60.5	60.7	60.5
4.2	55.9	56.7	57.5	58.9	60.1	61.1	62.0	62.6	63.0	63.3	63.1
4.3	58.1	58.9	59.7	61.2	62.5	63.5	64.4	65.1	65.6	65.9	65.8
4.4	60.3	61.2	62.0	63.5	64.9	66.0	66.9	67.6	68.2	68.5	68.6
4.5	62.6	63.5	64.4	65.9	67.3	68.5	69.4	70.2	70.8	71.2	71.4
4.6	64.9	65.9	66.7	68.3	69.8	71.0	72.0	72.8	73.0	73.9	74.2
4.7	67.3	68.2	69.1	70.8	72.3	73.5	74.6	75.5	76.2	76.7	77.0
4.8	69.7	70.7	71.6	73.3	74.8	76.1	77.3	78.2	78.9	79.5	79.9
4.9	72.1	73.1	74.1	75.8	77.4	78.8	80.0	80.9	81.7	82.3	82.9
5.0	74.6	75.6	76.6	78.4	80.0	81.5	82.7	83.7	84.5	85.2	85.9

Culvert Pipe-Arch Embankment Areas
 (Y=Height to Widest Section of Pipe)
 Equivalent Round Size

Y	12"	30"	36"	42"	48"	54"	60"	66"	72"
0.1	0.6	0.6	0.7	0.7	0.8	0.9	1.0	1.2	1.3
0.2	1.1	1.1	1.1	1.2	1.3	1.4	1.5	1.7	1.8
0.3	1.6	1.6	1.6	1.7	1.8	1.9	2.1	2.2	2.4
0.4	2.0	2.2	2.2	2.2	2.24	2.5	2.6	2.8	2.9
0.5	2.8	2.7	2.7	2.7	2.9	3.1	3.2	3.4	3.5
0.6	3.7	3.6	3.5	3.4	3.4	3.7	3.8	4.0	4.2
0.7	4.6	4.6	4.5	4.4	4.2	4.1	4.5	4.7	4.9
0.8	5.5	5.6	5.6	5.5	5.3	5.0	4.9	5.4	5.6
0.9	6.5	6.6	6.7	6.7	6.5	6.2	5.9	5.8	5.7
1.0	7.5	7.7	7.8	7.9	7.8	7.5	7.1	6.8	6.7
1.1	8.6	8.8	9.0	9.1	9.1	8.9	8.6	8.1	7.8
1.2	9.7	10.0	10.2	10.4	10.4	10.3	10.0	9.6	9.2
1.3	10.8	11.2	11.5	11.7	11.8	11.7	11.5	11.2	10.8
1.4	12.0	12.4	12.8	13.1	13.2	13.2	13.1	12.8	12.4
1.5	13.2	13.7	14.1	14.5	14.7	14.7	14.6	14.4	14.1
1.6	14.5	15.0	15.5	15.9	16.2	16.3	16.3	16.1	15.8
1.7	15.8	16.4	16.9	17.4	17.7	17.9	17.9	17.8	17.6
1.8	17.1	17.8	18.4	18.9	19.3	19.5	19.6	19.6	19.4
1.9	18.5	19.2	19.9	20.4	20.9	21.2	21.4	21.4	21.3
2.0	19.9	20.7	21.4	22.0	22.6	22.9	23.1	23.2	23.2
2.1	21.4	22.2	23.0	23.7	24.3	24.7	25.0	25.1	25.1
2.2	22.9	23.8	24.6	25.4	26.0	26.5	26.8	27.0	27.0
2.3	24.4	25.4	26.3	27.1	27.8	28.3	28.7	29.0	29.1
2.4	26.0	27.0	28.0	28.8	29.6	30.2	30.7	31.0	31.1
2.5	27.6	28.7	29.7	30.6	31.5	32.1	32.6	33.0	33.2
2.6	29.3	30.4	31.5	32.5	33.4	34.1	34.7	35.1	35.3
2.7	31.0	32.2	33.3	34.3	35.3	36.1	36.7	37.2	37.5
2.8	32.7	34.0	35.2	36.3	37.3	38.1	38.8	39.3	39.7
2.9	34.5	35.8	37.1	38.2	39.4	40.2	41.0	41.5	41.9
3.0	36.3	37.7	39.0	40.2	41.4	42.3	43.1	43.8	44.2
3.1	38.2	39.6	41.0	42.2	43.5	44.5	45.4	46.1	46.6
3.2	40.1	41.6	43.0	44.3	45.7	46.7	47.6	48.4	48.9

Culvert Pipe-Arch Embankment Areas
(Y=Height to Widest Section of Pipe)
Equivalent Round Size

Y	24"	30"	36"	42"	48"	54"	60"	66"	72"
3.3	42.0	43.6	45.1	46.4	47.8	48.9	49.9	50.7	51.3
3.4	44.0	45.6	47.2	48.6	50.1	51.2	52.3	53.1	53.8
3.5	46.0	47.7	49.3	50.8	52.3	53.5	54.6	55.6	56.3
3.6	48.1	49.8	51.5	53.0	54.6	55.9	57.1	58.1	58.8
3.7	50.2	52.0	53.7	55.3	57.0	58.3	59.5	60.6	61.4
3.8	52.3	54.2	56.0	57.6	59.4	60.7	62.0	63.1	64.0
3.9	54.5	56.4	58.3	60.0	61.8	63.2	64.6	65.7	66.6
4.0	56.8	58.7	60.6	62.4	64.3	65.7	67.1	68.4	69.3
4.1	59.0	61.0	63.0	64.8	66.8	68.3	69.8	71.0	72.0
4.2	61.3	63.4	65.4	67.3	69.3	70.9	72.4	73.8	74.8
4.3	63.7	65.8	67.8	69.8	71.9	73.6	75.1	76.5	77.6
4.4	66.0	68.2	70.3	72.4	74.5	76.2	77.9	79.3	80.5
4.5	68.5	70.7	72.9	75.0	77.2	79.0	80.6	82.2	83.4
4.6	70.9	73.2	75.5	77.6	79.9	81.7	83.5	85.0	86.3
4.7	73.4	75.8	78.1	80.3	82.6	84.5	86.3	88.0	89.3
4.8	76.0	78.4	80.7	83.0	85.4	87.4	89.2	90.9	92.3
4.9	78.5	81.0	83.4	85.8	88.2	90.2	92.2	93.9	95.3
5.0	81.2	83.7	86.2	88.5	91.1	93.2	95.1	97.0	98.4

**Elliptical Culvert Pipe Embankment Areas
(Y = Height to Center of Pipe)**

Equivalent Round Size

0.1	0.4	0.4	0.4	0.4	0.4	0.4	0.4	0.4	0.4
0.2	0.9	0.9	0.9	0.9	0.9	0.9	0.9	0.0	0.9
0.3	1.4	1.4	1.4	1.4	1.4	1.4	1.4	1.4	1.4
0.4	2.0	2.0	1.9	1.9	1.9	1.9	1.9	1.9	1.9
0.5	2.6	2.6	2.6	2.5	2.5	2.5	2.5	2.5	2.5
0.6	3.3	3.2	3.2	3.2	3.2	3.2	3.2	3.2	3.2
0.7	4.0	4.0	3.9	3.9	3.9	3.9	3.9	3.9	3.9
0.8	4.9	4.8	4.7	4.7	4.7	4.6	4.6	4.6	4.6
0.9	5.9	5.7	5.6	5.5	5.5	5.4	5.4	5.4	5.4
1.0	6.9	8.7	6.5	6.4	6.4	6.3	6.3	6.2	6.2
1.1	8.0	7.8	7.5	7.4	7.3	7.2	7.2	7.1	7.1
1.2	9.1	9.0	8.6	8.4	8.3	8.2	8.2	8.1	8.1
1.3	10.3	10.2	5.9	9.5	9.4	9.3	9.2	9.1	9.1
1.4	11.5	11.5	11.2	10.8	10.6	10.4	10.3	10.2	10.1
1.5	12.7	12.8	12.6	12.2	11.9	11.6	11.5	11.4	11.3
1.6	14.0	14.1	14.0	13.7	13.3	12.9	12.7	12.6	12.5
1.7	15.3	15.5	15.4	15.2	14.9	14.3	14.1	13.9	13.7
1.8	16.6	16.9	16.9	16.7	16.3	15.9	15.5	15.2	15.1
1.9	18.0	18.3	18.4	18.3	18.1	17.6	17.0	18.7	16.5
2.0	19.4	19.8	19.9	19.9	19.8	19.4	18.7	18.2	18.0
2.1	20.9	21.4	21.5	21.6	21.5	21.1	20.6	19.9	19.6
2.2	22.4	23.0	23.2	23.3	23.3	23.0	22.5	21.7	21.2
2.3	24.0	24.6	24.8	25.0	25.1	24.8	24.4	23.7	23.0
2.4	25.6	26.2	26.0	26.8	26.9	26.7	26.4	25.7	24.9
2.5	27.2	27.9	28.3	28.6	28.8	28.7	28.4	27.9	27.1
2.6	28.9	29.7	30.1	30.5	30.7	30.7	30.4	29.9	29.2
2.7	30.6	31.4	31.9	32.4	32.7	32.7	32.5	32.1	31.5
2.8	32.3	33.3	33.8	34.3	34.7	34.8	34.7	34.3	33.7
2.9	34.1	35.1	35.7	36.3	36.7	36.9	36.8	36.5	36.0
3.0	35.9	37.0	37.7	38.3	38.8	39.0	39.1	38.8	38.4
3.1	37.8	38.9	39.7	40.4	40.9	41.2	41.3	41.1	40.7
3.2	39.7	40.9	41.7	42.5	43.1	43.6	43.6	43.4	43.2
3.3	41.7	42.9	43.8	44.6	45.3	45.7	45.9	45.8	45.6
3.4	43.7	45.0	45.9	46.8	47.5	38.0	48.3	48.2	48.1
3.5	45.7	47.1	48.1	49.0	49.8	50.4	50.7	50.7	50.6
3.6	47.8	49.2	50.3	51.3	52.1	52.7	53.2	53.2	53.2
3.7	49.9	51.4	52.5	53.6	54.5	55.2	55.7	55.8	55.8
3.8	52.0	53.6	54.8	55.9	56.9	57.6	58.2	58.4	58.5
3.9	54.2	55.9	57.1	58.3	59.3	60.1	60.8	61.0	61.2
4.0	56.4	58.2	59.4	60.8	61.8	62.7	63.4	63.7	63.9
4.1	58.7	60.5	61.8	63.2	64.3	65.3	66.0	66.4	66.7
4.2	61.0	62.9	64.3	65.7	66.9	67.9	68.7	69.1	69.5
4.3	63.4	65.3	66.7	68.3	69.5	70.6	71.8	71.9	72.4
4.4	65.8	67.8	69.3	70.8	72.1	73.3	74.2	74.8	75.3
4.5	68.2	70.3	71.8	73.5	74.8	76.0	77.1	77.6	76.2
4.6	70.7	72.8	74.4	76.1	77.5	78.8	79.9	80.5	81.2
4.7	73.2	75.4	77.0	78.8	80.3	81.6	82.8	83.5	84.2
4.8	75.7	78.0	79.7	81.6	83.1	84.5	85.7	86.5	87.3
4.9	78.3	80.6	82.4	86.3	85.9	87.4	89.7	89.5	90.4
5.0	80.9	83.3	85.2	87.2	88.8	90.4	91.7	92.6	93.5

718.04 METHOD OF MEASUREMENT

718.05 BASIS OF PAYMENT

719.00 FLEXIBLE PIPE CULVERTS (CORRUGATED METAL AND PLASTIC)

719.01 DESCRIPTION

1. This work shall consist of furnishing and installing new corrugated metal pipes and pipe arches and the relaying of existing corrugated metal pipe and pipe arches.

719.02 MATERIAL REQUIREMENTS

1. Pipe Marking. SSHC Tables 1035.01 & 1036.01 contain the required minimum gage or sheet thickness for the various pipe diameters. The [Materials and Sampling Guide](#) provides that the necessary tests for acceptance will be handled by the Materials and Research Division. Material samples need not be taken by project personnel unless a special request is made for samples. The diameter of the pipe and number of sections of pipe covered by each heat number and delivered to each culvert location should be recorded in the culvert notebook. The pipe shipment should be checked against the shipment report and any discrepancy should be reported to the Project Manager. The pipe shipment should also be checked for shipping damage and any damage noted should also be reported to the Project Manager.
2. Ordering Material
 - a. The contractor is not permitted to order or deliver corrugated metal pipe or pipe arches until a "culvert order list" listing the correct sizes and lengths of pipe is furnished by the Project Manager.

719.03 CONSTRUCTION METHODS

1. Excavating and Backfilling
 - a. Refer to Section 702 of this manual and Standard Plan 411.
2. Installation
 - a. The culvert inspector should insist on careful handling of the corrugated metal pipes or pipe arches. Corrugated metal pipes or pipe arches should be lifted and moved with a rope sling or similar device which will not damage the galvanized or polymer coated surfaces of the pipes or pipe arches. The contractor should not be allowed to drag the pipes or pipe arches over abrasive surfaces as this will also damage the galvanized or polymer coated surfaces.
 - b. Corrugated metal pipes and pipe arches shall be laid with the inside circumferential laps lapped downstream so that the water will flow over the lap. The pipe shall be rotated so that the longitudinal laps are horizontal. When joining sections of pipe, the connecting bands should be pulled up as tight as possible. The band should be tapped with a wooden mallet as the bolts are tightened. Excessive pressure on the bolts should be avoided to keep from pulling the steel angle loose from the band. A gap of about 1 inch (25mm) should be allowed between the pipe ends being joined,

719.04 METHOD OF MEASUREMENT

719.05 BASIS OF PAYMENT

720.00 CONCRETE PIPE CULVERTS

720.01 DESCRIPTION

1. This work shall consist of furnishing and installing new reinforced concrete culvert pipe (round, pipe-arch and elliptical), reinforced concrete slotted pipe and the relaying of existing reinforced concrete pipe.

720.02 MATERIAL REQUIREMENTS

1. Pipe Marking. Each section of pipe used should be marked with the fabrication inspector's initial and the class of pipe, when it arrives at the site. The culvert inspector should not permit the laying of any section that does not have these markings. The project manager will receive a copy of the "Report of Shipment of Reinforced Concrete Pipe" (NDOT Form 420), listing the size, class, length, number of sections of pipe, the inspector's identification mark and stock report number. The inspector will use the information contained in this report to verify approval of reinforced concrete pipe received on the project. The diameter, class, length, number of sections and the pipe identification number shall be recorded in the culvert notebook. Each section of pipe should be examined for damaged ends, cracks and evidence of poor manufacture. All irregularities should be referred to the Project Manager before using of the pipe.
2. Ordering Material
 - a. The contractor is not permitted to order or deliver culvert pipe until a "culvert list" listing the correct sizes and lengths of pipe is furnished by the Project Manager.
 - b. The Project Manager shall furnish a pipe list for driveway and sewer requirements.
 - c. The District Construction Engineer, and the Project Manager should go over the drainage situation and features in the field to confirm that the structures shown in the plans are adequate to handle the drainage. The cross sections taken at each culvert site should be plotted, the roadway cross section template and the structure plotted thereon at the proper flow line elevations, and the length of the structure thus determined. If the Project Manager includes either a larger drainage structure, or an additional drainage structure in the culvert list, the PM should, if possible, specify the same type of structure, or the same kind of pipe (culvert pipe, concrete pipe or corrugated metal pipe) as is shown in the approved plans for the project for the other structures. If the PM decides to alter the pipe size, location or configuration: the PM should review the changes to the culvert design should be reviewed with the Roadway designer to verify that the hydraulic performance is maintained.
 - d. In detailing and ordering the pipe culverts, the following rules should be followed for all kinds of culvert pipe (concrete pipe, corrugated metal pipe or culvert pipe):
 - (i) The overall length of culvert pipe should be given to the closest 2 ft (600 mm).

- (ii) The minimum distance from outlet end of the pipe to the break point of a broken back pipe culvert shall be 20 ft where possible.
- (iii) The dimensions from ends of the pipe to break points, or between break points of a broken-back pipe culvert should be given to the closest 2 ft (600 mm) along the centerline of the pipe. The fabricator will be permitted to locate the elbows 1 foot (300 mm) in either direction from the locations shown in the culvert sketch.
- (iv) Generally, pipe culverts should not be designed or constructed with elbows of less than 5 degrees.
- (v) Prepare a sketch for each broken-back pipe culvert, designing and detailing the structure using the chart "Slope Data for Pipe Culvert" as a guide, and including dimensions, details and elevations as shown in the sample culvert sketch shown in this Subsection.
- (vi) Pipe arch culverts are to be detailed and dimensioned the same as round pipe culverts
- (vii) If flared end sections are to be installed, the pay length shall be the order length shown in the culvert list and sketch. A note should be made as part of the list indicating that order lengths do not indicate the "Y" distances shown in the applicable Standard Plan in the case of metal pipe.
- (viii) The condition, kind of pipe, diameter and lengths right and left of centerline should be carefully checked before ordering extensions for an existing pipe culvert. Careful checking will eliminate ordering extensions which are improper as to length, diameter, kind of pipe, etc.
- (ix) If settlement or subsidence is anticipated under higher fills, pipe culverts and box culverts should be cambered. The plans will usually include a "Camber Note" which will state that the pipe culverts should be laid and box culverts constructed on parabolic camber grade as shown in the applicable standard plan, and will state the proportion of fill height which the foundation soil is expected to settle. Settlement of subsidence is generally zero at the toe of the slope, and at a maximum at the shoulder line.

720.03 CONSTRUCTION METHODS

- 1. Excavation and Backfilling
 - a. See Section 702.
- 2. Installation
 - a. Begin laying concrete pipe at the downstream end of the culvert with the groove or bell portion of each section upstream.
 - b. Irrigation culverts shall be constructed of concrete pipe and must have approved gaskets at the joints. Concrete sewer pipe shall also have approved joints. These gaskets shall be installed as per the manufacturer's recommendations and standards. Here is example of how to calculate payment for excavation.

720.04	METHOD OF MEASUREMENT
720.05	BASIS OF PAYMENT
721.00	DRIVEWAY CULVERT PIPE
721.01	DESCRIPTION
721.02	MATERIAL REQUIREMENTS
721.03	CONSTRUCTION METHODS
721.04	METHOD OF MEASUREMENT
721.05	BASIS OF PAYMENT
722.00	SEWERS
722.01	DESCRIPTION
722.02	MATERIAL REQUIREMENTS
1.	Concrete sewer pipe shall also have approved joints. All sewer pipe shall at a minimum have an ASTM 443 sewer pipe joint. When required by the designer, an ASTM 361 joint shall be used.
722.03	CONSTRUCTION METHODS
722.04	METHOD OF MEASUREMENT
722.05	BASIS OF PAYMENT
723.00	TAPPING EXISTING DRAINAGE AND SEWER FACILITIES
723.01	DESCRIPTION
723.02	CONSTRUCTION METHODS
723.03	METHOD OF MEASUREMENT
723.04	BASIS OF PAYMENT
724.00	INSTALLATION AND REMOVAL OF FLARED-END SECTIONS
724.01	DESCRIPTION
724.02	MATERIAL REQUIREMENTS
724.03	CONSTRUCTION METHODS
724.04	METHOD OF MEASUREMENT
724.05	BASIS OF PAYMENT
725.00	BAR GRATES FOR FLARED-END SECTIONS
725.01	DESCRIPTION
725.02	MATERIAL REQUIREMENTS
725.03	CONSTRUCTION METHODS
725.04	METHOD OF MEASUREMENT
725.05	BASIS OF PAYMENT

726.00	CULVERT SANDFILL
726.01	DESCRIPTION
726.02	MATERIAL REQUIREMENTS
726.03	CONSTRUCTION METHODS
726.04	METHOD OF MEASUREMENT
726.05	BASIS OF PAYMENT
727.00	SUBSURFACE DRAINAGE MATTING
727.01	DESCRIPTION
727.02	MATERIAL REQUIREMENTS
727.03	CONSTRUCTION METHODS
727.04	METHOD OF MEASUREMENT
727.05	BASIS OF PAYMENT
728.00	RIPRAP FILTER FABRIC
728.01	DESCRIPTION
728.02	MATERIAL REQUIREMENTS
728.03	CONSTRUCTION METHODS
728.04	METHOD OF MEASUREMENT
728.05	BASIS OF PAYMENT
729.00	DECK JOINT SEALS
729.01	DESCRIPTION
729.02	MATERIAL REQUIREMENTS
729.03	CONSTRUCTION METHODS
729.04	METHOD OF MEASUREMENT
729.05	BASIS OF PAYMENT
730.00	STRIP SEALS
730.01	DESCRIPTION
730.02	MATERIAL REQUIREMENTS
730.03	CONSTRUCTION METHODS
730.04	METHOD OF MEASUREMENT
730.05	BASIS OF PAYMENT
731.00	JACKING CULVERT PIPE, SEWER PIPE, AND CASING
731.01	DESCRIPTION
731.02	MATERIAL REQUIREMENTS
731.03	CONSTRUCTION METHODS

731.04	METHOD OF MEASUREMENT
731.05	BASIS OF PAYMENT
732.00	LEAD-BASED PAINT REMOVAL
732.01	DESCRIPTION
732.02	MATERIAL REQUIREMENTS
732.03	CONSTRUCTION METHODS
732.04	METHOD OF MEASUREMENT
732.05	BASIS OF PAYMENT
733.00	BRIDGE DECK AND APPROACH SLAB SMOOTHNESS
733.01	DESCRIPTION
733.02	EQUIPMENT
733.03	TEST PROCEDURE
733.04	EVALUATION
733.05	SURFACE CORRECTION
733.06	ACCEPTANCE
734.00	PRECOMPRESSED POLYURETHANE FOAM (PPF) JOINT
734.01	DESCRIPTION
734.02	MATERIAL REQUIREMENTS
734.03	CONSTRUCTION METHODS
734.04	METHOD OF MEASUREMENT
734.05	BASIS OF PAYMENT
735.00	BRIDGE ITEMS
735.01	BRIDGE DIAPHRAGMS

1. Steel diaphragms, if allowed, are shown in the plans for prestressed beam structures. Shop drawings are required for steel diaphragms showing details of beam layouts, location of the diaphragms, and location of mounting holes.
 - a. High strength bolts for steel diaphragms shall be tightened by Turn-of-Nut method. (Refer to *SSHC Subsection 708.03* for information on proper bolt inspection and installation.) Inspection and field installation acceptance will be based on observing proper Turn-of-Nut procedures. (A tensioning device and inspection torque wrench is recommended, but will not be required.)
 - b. Concrete diaphragms at piers of prestressed concrete girder bridges should be cast to 2/3 of their intended depth. The final 1/3 and the deck are then placed at the same time. However, there are instances where allowance has been given for specific diaphragms to be placed prior to slab placement. If there is a construction option shown in the plans, the diaphragm can be poured separate from the deck. Note the construction

joint detail will show how to strike-off the surface. Consult with the Construction Division in situations where the contractor requests to place concrete diaphragms other than as shown in the plans.

- c. Phased bridge decks which have inverted “T” girders should not have the portion of the diaphragms cast between the two girders on each side of the longitudinal phasing construction joint until the second phase deck is cast. If the girder diaphragms for the gap between the two girders which are on each side of the phasing joint are cast before the second phase deck is cast, the diaphragms will lock the girders under the second phase deck at a position higher than the phase 1 girders. Cast the diaphragms between the two girders that are on each side of the phasing construction joint at the time the second phase deck is cast. The remaining girder diaphragms in the second phase should be cast before the deck is cast.
 - (i) Casting the intermediate (midspan) diaphragms before the deck is cast removes some of the girder camber and will make the structure more stable for the deck casting.

735.02 BARRIER RAILS

735.03 DESCRIPTION

1. Fixed Form Jersey & Retrofit Rail
 - a. Before cast-in-place barrier rail is constructed on the existing bridge curb section, *SSHC Subsection 704.03* requires that old concrete which is to be in contact with the new concrete be cleaned of all laitance (loose particles of concrete, dirt, or other foreign materials).
 - b. Structurally, the existing curb surface need not be roughened, but must be clean. To assure a clean surface and to obtain maximum bond at the interface, sandblasting the old curb surface shall be required. Other methods of cleaning may be approved by the Project Manager.
 - c. Surface preparation, such as sandblasting, should be completed prior to setting the epoxy coated dowels.
 - d. When retrofit is part of a deck overlay, the contractor may request permission to place the finish machine on the retrofit rail. Construction's policy will be:
 - (i) A minimum cure time of at least 48 hours prior to placing the mass of a finish machine on the rail, AND
 - (ii) Finish machine rail support feet must be spaced less than 1'-9" (550 mm) apart.
 - (1) If these conditions are unacceptable to the contractor, a minimum cure time of 72 hours will be required. After 72 hours there are no special conditions for placing a finishing machine on the barrier rail.

2. Cast-In-Place (Retrofit) Barrier Rail
 - a. This work is routinely combined with a deck repair project and includes an overlay. Often contractors will place the new rail prior to placing overlay. In these situations, the contractor intends to place the finish machine's rail on top of the new barrier rail. Question: How long must the new rail cure before allowing the deck finishing machine to be placed on it?
 - (i) 48 hours must expire prior to placing the weight of a finishing machine on the rail.
 - (ii) Rail supports (legs) must be placed at a spacing of no greater than 18 inches (500 mm).
 - (iii) Rail supports and rail cannot be placed until the surface has sufficiently cured to prevent scuffing and/or marring.
 - (iv) Care must be taken to prevent damage to the face or back of the barrier rail.
3. Slip Form Barrier Rail
 - a. Slip form rails have at times displayed transverse cracks, longitudinal cracks, reinforcing steel shadows, and nonuniformity of top elevations. Consideration of the following construction problems and solutions will help to eliminate problems:
 - b. Longitudinal Cracks
 - (i) Longitudinal cracks and vertical cracks near posts can be prevented with proper construction techniques. (Consolidate uniformly, obtain proper rebar clearance and wet cure.)

735.04 MATERIAL REQUIREMENTS

1. See Section 706.

735.05 CONSTRUCTION METHODS

1. Concrete Surface Finish (Rail and Beams)
 - a. Ordinary surface finish is required for rails. Beams need only have "popcorns" filed.
2. Surface Finish
 - a. The type of surface finish required for concrete structures is governed by the special provisions, the plans and *SSHC Subsection 704.03*. A pre-construction study of these sources will bring to light any possible differences of opinion concerning requirements and allow time for their solution.
 - b. For either ordinary surface finish, rubbed finish, grout cleaned finish, or floated surface finishes, the contractor should be required to perform the work as promptly as practical after the removal of the forms. If this work is started promptly, and the surface finishing work performed before the concrete becomes excessively hardened, a much better surface finish will be obtained. Also, this better finish will be obtained with less work and consequently at lower cost.

- c. If the required finish is a rubbed finish, then *SSHC Subsection 704.03* does not authorize plastering an excess of mortar on the surface of the concrete. The mortar is to be applied, as stated in the Specifications.
- d. Note that proper rubbing is a sequence of three steps:
 - (i) The surface is thoroughly saturated and then rubbed with the medium coarse stone faced with mortar. The paste (rubbed up from the surface of the concrete, and not applied as a plaster) is left on.
 - (ii) The surface is wetted and rubbed with a fine carborundum stone. The paste is left to dry on the surface.
 - (iii) The dried paste is rubbed off completely with burlap. Some laborers will not distinguish between coarse and fine stones, or the contractor may originally furnish only one grade. Check with the Project Manager as to the proper degree of fineness of the stones being used, on the basis of the finished results. Request the Project Manager's inspection of the first finishing work done in order that the PM can set standards for methods and results in subsequent work. Ordinary surface finish, rubbed finish, grout cleaned finish, and floated surface finishes include leaving all chamfer lines and all plane surfaces intersection lines cut clean and straight.
- 3. Special provisions currently allow the use of a special surface coating as an alternate to a rubbed surface finish.
- 4. Special attention and inspection should be given to the close tolerance required in finishing of the concrete at the bearing plate areas on abutment and pier caps. Promptly after the concrete has hardened sufficiently, remove the anchor-bolt templates and finish the bearing area to a true surface. A small carpenter's level is very helpful to level the area. Prompt and efficient performance of this work will save much grinding of the hardened concrete at the time the bearing plates are set, and will yield better, more uniform bearing areas.

DIVISION 800

**ROADSIDE
DEVELOPMENT AND
EROSION CONTROL**

DIVISION 800
ROADSIDE DEVELOPMENT AND EROSION CONTROL

800.00 **GENERAL COMMENTS**

1. Introduction
 - a. The highway right-of-way is largely a disturbed environment, lacking a natural soil profile and subject to unusual runoff, strong winds and abnormal air turbulence, pollutants, wide temperature variations and other extremes. Seeding, sodding, erosion control and landscaping are used to deal with this disturbed environment and help to permanently stabilize it as soon as possible.
 - b. Plants and seeds are living things in contrast to concrete, steel, stone and asphalt which are the inanimate materials used in the major part of road construction. Plants change in shape, size, color and texture from season-to-season and year-to-year while the inanimate materials remain virtually constant.
 - c. Seeding and landscaping involve living materials used to stabilize the right-of-way, protect the concrete and steel construction and provide other functions to help safely direct the motorist. It is understandable that survival of these living materials is important to the entire roadway system.
 - d. These living materials need to be of the quality specified, properly installed and maintained so they produce the desired results of stabilizing the right-of-way to protect the construction and provide a complete roadway system.
2. General Inspection
 - a. Inspection personnel assigned to erosion control work should review project plans, specifications, special provisions, and road standards pertaining to erosion control. The right-of-way contracts should be reviewed for special treated areas not mentioned on the plans. For seeding, fertilizing, and mulching, a pre-measurement using slope distances of the project is needed before the contractor starts. Both the contractor and inspector need to know the quantities of seed, fertilizer, and mulch required on the project.
 - b. Attention should be given to the erosion control plan and proposal notes for the special items and conditions involved with each individual project.
 - c. Material delivered to the project and damaged due to improper storage or handling should be rejected, even though it may have been previously accepted.
 - d. The testing requirements for seed and fertilizer are outlined in the [*Materials Sampling Guide*](#).
 - e. The inspector is to observe the following operations:
 - (1) Application of seed, fertilizer, and mulch.
 - f. Record the quantities of these materials used in the project records. Record the drill settings for each type of seed mix.

800.01 REMOVING AND RESETTING TREES CHECKLISTS

1. Removing and Resetting Trees Checklist

SSHHC References: Section 825

Other References:

Equipment manufacturer recommendations

Special Provisions

Special Plan

Inspection Equipment: Tree Caliper

General Comments:

- a. Make sure the location for resetting the trees is accessible by the mechanical tree spade.
- b. Obtain from the contractor the equipment manufacturer's size rating for the tree spade and be sure the trees to be moved are within the allowable sizes for that machine. There may be size differences between evergreen trees and deciduous trees.
- c. The size is usually called out as a caliper dimension - This should be the diameter of the tree trunk at 300 mm (12 inches) above the ground for trees over 100 mm (4 inches) in diameter.
- d. After the trees have been properly set in their new location, make sure they are well watered. This watering and any required maintenance procedures in the Special Provisions are the most important part of keeping these plants alive.

2. Furnishing and Planting of Plant Materials CHECKLIST

SSHHC References: Section 825

Special Provisions

Other References: [American Standard for Nursery Stock](#) (current edition)

[Approved Products list](#)

Inspection Equipment: Tree calipers

Tape measure

General Comments:

- a. The "American Standard for Nursery Stock" tells the characteristics each type of plant should have for its size and is used in determining if the plants are acceptable.
- b. Preconstruction conference should be well in advance of the project starting date. Roadside Development and Compliance Unit Section personnel should be asked to attend.

3. Material Requirements:
 - a. Contractor planting operation must occur within the specified planting seasons.
 - b. Confirm that the plant material sources have been approved by Roadside Development and Compliance Unit.
 - c. Be sure all plant material is healthy and in good growing condition before allowing it to be planted.
 - (i) no serious injuries
 - (ii) no dry roots
 - (iii) no broken root balls
 - (iv) no insect pests or diseases
 - d. If plants must be stored, inspect the storage area to see if it meets the specifications.
 - e. Be sure products used meet the specifications.
 - (i) Approved planting fertilizer is pressure-formed pellets 20-10-5 @ 21 grams or 14-3-3 @ 16 grams.
 - (ii) Establishment period fertilizer shall be liquid urea with 28 to 32 percent nitrogen.
 - (iii) Wood mulch, approved by Roadside Development and Compliance Unit Section.
 - (iv) Wood stakes or metal stakes are the appropriate sizes.
 - (v) Guying material - approved by Roadside Development and Compliance Unit.
 - (vi) Absorbent polymer on approved product list.
 - (vii) Pre-emergent chemical is Dathal.
 - (viii) Post-emergent chemical is Roundup.
4. Construction Methods:
 - a. Planting area tilled and drilled according to the plans, details and specifications.
 - b. Bare roots plants are the most delicate to handle. Their roots must be kept moist at all times, in storage; when delivered to the project site, they should be coated with the absorbent polymer slurry and protected from sun, wind and cold so they do not get dry before planting. If it is obvious the roots have been allowed to dry out before getting planted, these plants should be rejected.
 - c. Planting procedures are called out in the specifications. If you have specific questions, contact Roadside Development and Compliance Unit.
 - (i) B&B material-set ball into hole onto undisturbed soil at same depth it was grown.
 - (ii) Plumb and partially backfill plants - no rocks or clods in backfill.

- (iii) Twine cut away from trunk and burlap pulled back on B&B plants.
 - (iv) Properly placed fertilizer tablets in backfill, correct number for size of plant.
 - (v) Backfilling completed properly - check for exposed roots on bare root plants after first watering and initial soil settlement. Make sure these are covered with soil immediately.
 - (vi) Plant material thoroughly watered at time of planting.
 - (vii) Properly pruned branches.
 - (viii) Trees staked and properly guyed.
 - (ix) Water basin constructed to hold at least the minimum amount of water called for in Table 825.01.
 - (x) Applied proper pre-emergent chemical.
 - (xi) Be sure mulch covers all tilled area to the specified depth.
- d. During the establishment period, check the project regularly to see that all procedures are being accomplished. This is the most critical time in the project to keep plants from being stressed before going into winter. Establishment procedure items are:
- (i) Pruning
 - (ii) Protect against pests and diseases
 - (iii) Regular watering
 - (iv) Replacing mulch
 - (v) Adjust stakes and guys
 - (vi) Control weeds
 - (vii) Remove dead plant material
- e. Make sure the contractor notifies you when they will be watering or doing other establishment work so you can check and document that it has been done properly. Be sure the contractor realizes this documentation is to their benefit also. If the project is not properly maintained, the contractor can be required to maintain the project for a second growing season.
5. Basis of Payment:
- a. Partial payment criteria and percentages are indicated in Table 825.02. (Check Special Provisions for possible changes.)
 - b. Inspection dates are approximately:
 - July 15** - to check establishment procedures
 - September 1** - count of plants in acceptable growing condition
 - June 1** - to final out project
 - c. Check Special Provision for other inspections that may be required.

6. Seeding Checklist

SSHC Reference: Section 801, 802, 803 Seeding Special Provisions

Other References: Project seeding Record, Section 804, 805, 806, 807

Inspection Crew: Construction Technician

Seeding Procedures:

- a. Give the seeding quantities to the contractor and Roadside Development and Compliance Unit.
- b. The seed will be mixed at the seed company and tagged with department furnished tags.
- c. Fertilizer is usually furnished bulk and must have the bulk fertilizer NDOT Form 125 (Appendix 1). If it is delivered mixed and bagged it still needs the form. If it is delivered bagged in its separate components, the label on the bag will be enough.
- d. Native grass drill must have either press wheels or drag chains (this is important the press wheels firm the seed bed and drag chains make sure the seed is covered.)
- e. Other seeding equipment hydro-seeder - big squirt gun must have agitation. Brillion seed box that drops seed between two corrugated rollers.
- f. Mulching equipment like cultipacker, crimper, mulch stabilizer, and mulch spreader should be inspected to confirm proper operation.
- g. Tillage equipment many shapes, sizes and descriptions, (common disc and field cultivator.)
- h. Soil preparation the PM must release the area to be seeded no preparation is to begin until the finish grade has been approved!
- i. Does maintenance have to fix and regrade areas? Notify the maintenance superintendent ahead of time!
- j. Is there a heavy weed growth that needs to be mowed?
- k. Mulch does the contractor have the proper mulch (some projects are specified prairie hay only.)
- l. Does the mulch have the noxious weed inspection certificate?
- m. Has the mulch been weighed in?
- n. Seed bed preparation and seeding procedures:

FOR DRILLED SEED:

- a. Fertilize
- b. Disc
- c. Or disc and then fertilize
- d. Harrow - several discings & harrowings may be necessary to produce a firm seed bed

- e. Seed
- f. Mulch
- g. Crimp mulch

FOR HYDRO-SEEDING AND BROADCAST SEEDING:

- a. Fertilize
- b. Disc
- c. Or disc and then fertilize
- d. Harrow - several discings & harrowings may be necessary to produce a firm seed bed except if too steep to operate equipment on
- e. Seed
- f. Harrow seed into the soil unless too steep
- g. Mulch & crimp or hydro mulch

FOR BRILLION SEEDING:

- a. Same as for drilled seed (unless it is hydro-mulched)

GENERAL:

- a. Some hydro-seeding is done on very steep slopes that must be left in a roughened condition by the grader, or there is no way to make a seed bed.
- b. "Rule of Thumb", Whatever is seeded in a day must also be mulched and crimped in that same day." Exceptions unexpected rain pay attention to the weather reports and conditions.
- c. Establish a 1 hectare (2 ½ acre) or small 0.4 hectare (1 acre) plot for mulch. Mulch and crimp this area and use it for a reference.
- d. Send in the project seeding record to Roadside Development and Compliance Unit upon completion of seeding.
- e. Please remind the seeding contractors to do a good job of cleaning out the seeding drills when changing from Type "A" to Type "B". Type "A" has taller grasses than we want on our shoulder areas.
- f. Changing from Type "B" to Type "A" does not require a clean out.

7. Sodding Checklist

SSHC Reference: *Section 809 Sodding*

Other References: Your New Sod Door Hanger - See Construction Engineer

Inspection Crew: Construction Technician

Inspection Equipment: NA

Sodding Procedures: (General Comments)

- a. Are the sodding dates in conformance with the Roadside Development and Compliance Unit Specifications?

- b. Has Roadside Development and Compliance Unit been notified where the sod is coming from?
- c. Has the contractor obtained the proper fertilizer? (urea-formaldehyde fertilizer is blue.)
- d. What pre-emergent is the contractor going to use and at what rate should it be applied?
- e. Where is the contractor's water source and what is the watering plan - (adequate watering is the key to sodding success.)
- f. Is the finish grade approved for sod to be laid on? (Make sure the Project Manager has approved the finish grade.)
- g. Has the soil next to the adjoining surfaces been properly lowered?
- h. Distribute the "Your New Sod" door hanger.
- i. Apply the pre-sodding fertilizer to the prepared seed bed.
- j. Enforce the watering requirement
- k. Sometimes rejected sod may be overseeded (contact Roadside Development and Compliance Unit for the mixture).

8. Erosion Control Checklist

SSHC Reference: Section 810 Erosion Control & Special Provisions

Other References: [Approved Products List](#)

Inspection Crew: Construction Technician

Inspection Equipment: NA

General Comments:

- a. Has the finish grade been accepted for this area?
- b. Is the material on the [Approved Products List](#)?
- c. Does the contractor have the right pins?
- d. Does the contractor have the right fertilizer? (Special Provisions)
- e. Is the seed bed properly prepared?
- f. Does the seed have the department tags for this project?
- g. Usual work sequence:
 - (i) Soil preparation including the slots for the erosion checks
 - (ii) Fertilize
 - (iii) Install filter fabric for check slots and soil fill
 - (iv) Seed and rake the seed into the soil
 - (v) Install erosion control material
 - (vi) Some erosion control materials come with the filter fabric attached. When this material is used, direct seed into the erosion control material and then soil is spread over the seed

Roadside Development and Compliance Unit:

- a. Questions call 402-479-4499, Roadside Development and Compliance Unit.

9. Erosion Checks Checklist

SSHC Reference: Section 814 Erosion Checks & Special Provisions

Other References: [Approved Products List](#)

Inspection Crew: Construction Technician

Inspection Equipment: NA

General Comments:

- a. Work generally performed in conjunction with erosion control after an area is final graded.
- b. Make sure that the center bale is lower than the outside bales.
- c. The erosion control material for the erosion checks must match the erosion control material used in the ditch. Is the material on the [Approved Products List](#)?
- d. Work performed similar to erosion control.
- e. Seed is never to be placed under the filter fabric - only on top of the filter fabric.
- f. Some erosion control materials have the filter fabric attached. When this occurs, the seed is directly seeded onto the erosion control material and then soil is spread over the seed.
- g.
 - (i) "Temporary Silt Checks" (TSC) are to be installed as soon as rough grading begins. TSC should be placed as shown in the plans or as directed by the engineer.
 - (ii) Temporary Silt Checks (TSC) have to be removed in order for final grading to be completed. However, once final grading is complete, the TSC's need to be reinstalled.
 - (iii) The contractor does not have to reinstall TSC if instead the permanent erosion checks are available and will be installed immediately after finish grading.

Roadside Development and Compliance Unit:

- a. Questions call 402-479-4499, Roadside Development and Compliance Unit

10. Silt Fencing Checklist

SSHC Reference: Section 816 Silt Fencing & Special Provisions

Other References: Silt Fence Guideline & [Approved Products List](#)

Inspection Crew: Construction Technician

Inspection Equipment: None

Silt Fencing Procedures:

General Comments:

- a. Silt fencing is a first item of business before any soil is disturbed.
- b. Does the contractor have the right material?
- c. Is the material on the [Approved Products List](#)?
- d. Does the silt fence location need to be adjusted to function better?
- e. Silt fences only work when they are:
 - (i) installed correctly
 - (ii) kept clean
 - (iii) kept repaired

Roadside Development and Compliance Unit:

- a. Questions call 402-479-4499, Roadside Development and Compliance Unit

11. Slope Protection Checklist

SSHC Reference: Section 808 Slope Protection & the Special Provision

Other References: None

Inspection Crew: Construction Technician

Inspection Equipment: Yard stick, meter stick and small balance scale

Procedures and General Comments:

- a. The mulch must be prairie hay and certified as noxious weed free.
- b. The seed will be mixed at the seed company and tagged with department supplied tags.
- c. All areas possible are to have the seed drilled. The drilled seed will establish much faster than broadcast seed. The percentage of the area to be drilled is given in the Special Provisions.
- d. Hay buster machines have proven to be satisfactory for the mechanical application of the mulch.
- e. Sampling for the proper weight of mulch per yd² or m². Use the meter stick or yard stick which ever applies and gather all the hay in a square before crimping and weigh this on the scale the results are approximate. Use them as a guide and not as an absolute.
- f. Best hay information: Establish a test plot with the exact amount of hay per yd² or m² crimp and use this plot for a visual comparison.

Roadside Development and Compliance Unit:

- a. Questions call 402-479-4499, Roadside Development and Compliance Unit.

12. Slope Protection Netting Checklist

SSHC References: Section 810 Slope Protection Netting

Other Reference: [Approved Products List](#) & Plans

Inspection Crew: Construction Technician

Inspection Equipment: NA

Procedures & Comments:

- a. The slope protection must be complete before the netting is installed.
- b. Is the netting on the [Approved Products List](#)?
- c. Are the pins the right length and wire size?
- d. Potential problem is inadequate pinning.
- e. Questions - call (402) 479-4499, Roadside Development and Compliance Unit.

13. Covercrop Seeding Checklist

SSHC References: *Section 802 Covercrop Seeding*

Other References: None

Inspection Crew: Construction Technician

Inspection Equipment: None

Procedures & Comments:

- a. Covercrop seeding is intended to reduce erosion and siltation.
- b. This cannot happen unless the covercrop seeding is done in a timely manner.
- c. This does not mean to wait and have the permanent seeder put in the covercrop and then overseed with the permanent seed.
- d. The covercrop seed should be done at least 45 days in advance of the permanent seeding to be of any use!
- e. Covercrop will not be used as a matter of course on "overlay" project, but could be added by change order if the need ever arose.
- f. Piper Sudan has been removed from the covercrop lists.
- g. Questions - call Roadside Development and Compliance Unit (402) 479-4499.

14. Peat Moss Checklist

- a. General Comments: Although peat moss is not used often, it is a very important item when specified.
- b. The peat moss adds trace elements that some plants need and can help hold water in the planting soil and help loosen heavy clay in some cases.
- c. Make sure that the peat moss is well mixed with the backfill before it is placed in the planting hole so it gets distributed evenly throughout the planting hole.

801.00 PERMANENT SEEDING

SSHC References Section 801 – Permanent Seeding

Other References

General information

The normal periods for permanent seeding are from March 1 to June 30 and from August 1 to December 31 or freeze up. These dates may be modified by the Special Provisions.

Installation Procedures

1. Preparation of Seed Bed

Before seeding operations commence, care should be taken to properly prepare the area to be seeded. Areas around culvert headwalls and wingwalls, shoulders, flumes, sign posts, guardrail, and other structures require special attention. The seed bed shall be worked to a depth of at least 50 mm (2 inches) deep.

2. Seed

The seed is mixed at the seed company and overseen by Roadside Development.

3. Measurement

The seed measurements should be discussed at the preconstruction conference and a date established as to when they would be provided to the contractor. The Department normally will buy any excess seed. Pay for what we want and get.

4. Inspection Considerations

The following items should be noted when inspecting hydroseeding:

A fanning motion or horizontal motion of the seeding nozzle insures uniform application of the seed. Do not use an up and down motion; it results in seed application too heavy near the seeder and too thin at the far reach of the spray.

The seeder tank must be cleaned when changing seed mixtures.

5. Photos Needed

802.00 COVER CROP SEEDING

SSHC References Section 802 – Cover Crop Seeding

Other References:

Stormwater Pollution Prevention Plan

NDOT Stormwater Pocket Guide

1. General information

a. Cover Crop Seeding is the planting of a temporary vegetative cover on disturbed areas with appropriate rapid growing annual plants. Cover Crop Seeding may be used on soil stockpiles, dikes, dams, sediment basin slopes, temporary road embankments, or on finish grades the will be exposed for more than 14 days. This practice is intended to reduce erosion and siltation by providing a cover that can be effective for an entire growing season.

b. Refer to Table 802.01 in the Standard Specifications for specific information regarding approved cover crop varieties and rate of application.

- c. The seed may arrive in bags or bulk. When bulk seed is being used, it must arrive at the project with current purity and germination tests.
 - d. Fertilizer is typically not used with cover crop unless specified else were in the contract.
 - e. Temporary mulch may be used with cover crop when weather conditions are such that germination within 10 days may not occur.
2. Installation Procedures
- a. The planting of cover crop should begin within 24 hours of the completion of grading activities.
 - b. The seedbed needs to be prepared by tilling to a depth of 1 ½ inches.
 - c. Covercrop may be either drill seeded or seeded by broadcasting and harrowing. This should be verified, as the Special Provisions may dictate a specific method.
 - d. Cover crop should be used even if the permanent seeding is pending within a few weeks.
 - e. Water for seeding should be used when the soil is excessively dry and is subject to wind erosion.
3. Measurement
- a. Cover Crop Seeding is measured in acres of ground surface seeded.
 - b. The area is calculated by multiplying the length x width of the area seeded.
 - c. If GPS is used to measure the area, care should be taken to ensure that the actual slope length is used in the calculation, especially on large slopes.
4. Inspection Considerations
- a. Verify the proper seed types are being planted based on the time of year and location of the planting.
 - b. Monitor the growth of cover crop, as reseeding may be needed if growth is not adequate to protect the site from erosion.
5. Photos Needed
- a. A photo of cover crop showing minimum height of effectiveness
 - b. A photo of fully established cover crop

803.00 TEMPORARY SEEDING

SSHHC References Section 803 – Temporary Seeding

Other References

General information

Installation Procedures

Measurement

Inspection Considerations

Photos Needed

804.00

FERTILIZING

SSHC References Section 804 – Fertilizing

Other References

NDOT Form 125 is required for all bulk fertilizer and bulk blended and then bagged material.

1. General information
 - a. "Fertilizer Grade" refers to the percentages of nitrogen (N), phosphoric acid (P_2O_5) and potassium (K_2O) present. The contractor must furnish corresponding scale ticket from an approved scale for fertilizer used in the work.
2. Installation Procedures
 - a. The fertilized area shall be disced prior to seeding. Harrowing may also be required.
3. Measurement
 - a. Our fertilizers are specified in amounts of actual ingredients. A typical specification might read:
 $N_2 = 32$ or 40 kg/ha (26 to 35 lb/acre)
 $P_2 = 103$ or 108 kg/ha (90 to 95 lb/acre)
Typically, the contractors will furnish a 16-48-0 or an 18-46-0 material. These numbers are expressed as a percentage of the total mass. The first number represents the percentage of nitrogen relative to the total mass, the second number is the percent of phosphorous and the third is potassium.
In order for the contractor to furnish the 36 kg/ha of N_2 (nitrogen) he/she would apply 225 kg (bulk) material - this would also give us the 108 kg/ha of P_2 (phosphorus) when using 16-48-0 fertilizer.
Required: 36 kg/ha of N_2
Required Fertilizer: 16-48-0 (16% N_2)
 $36 \text{ kg/ha} = (.16) \times (\text{Unknown Bulk Quantity})$
 $225 \text{ kg/ha} = \text{Bulk Quantity}$
 $\text{kg/ha of } P_2 = (.48) \times 225 = 108$
NDOT specified sulpher coated urea fertilizer is typically a 36-0-0 or a 37-0-0 material and is specified at 67 kg/ha (60 lb/acre):
Required: 67 kg/ha
Required Fertilizer: 36-0-0 36% N_2
 $67 \text{ kg/ha} = (.36) \times (\text{Unknown Bulk Quantity})$
 $186 \text{ kg/ha Bulk with } 36-0-0$
 $67 \text{ kg/ha} = (.37) \times (\text{Unknown Bulk Quantity})$

181 = kg/ha Bulk with 37-0-0

NDOT specified urea formaldehyde fertilizer is a 38-0-0 material and is usually specified at 85 kg of N₂/ha (35 lb of N₂/Acre).

Required: 85 kg/ha of N₂

38% N₂ in the fertilizer

85 kg/ha = (.38) x (Unknown Bulk Quantity)

224 kg/ha = Bulk Quantity

Curve Ball

The contractor wants to use an 11-52-0 to satisfy the 36 or 40 kg N₂ and the 103 or 108 kg/ha requirement for P₂. How much 11-52-0 should be applied? (Our application rates state minimum = 36 or 40 & 103 or 108).

Required: 36 kg/ha N₂

103 kg/ha P₂

Contractor's fertilizer is 11% N₂ or 52% P₂.

36 kg/ha - (.11) x (Unknown Bulk Quantity)

327 kg/ha = Bulk Quantity to get N₂ and

(.52) x (327 kg/ha) = 170 kg/ha P₂

This would be an excess of P₂ (327 x 52% = 170 kg of P₂), but this is what must be applied to satisfy the minimum N₂ requirement.

b. Slider

The contractor wants to use the 11-52-0 to satisfy the P₂ requirement. How much 33-0-0 will have to be added to the mixture to satisfy the N₂ requirement.

Required: P₂ = 103 kg/ha

N₂ = 36 kg/ha

Fertilizers: 11-52-0

33-0-0

P₂: 103 kg/ha = (.52) x (Unknown Bulk Quantity)

198 kg/ha = Quantity of 11-52-0.

But now how much N₂ are we short?

(.11) x (198) = 21.78 kg/ha of N₂

Therefore,

(36 - 21.78) kg/ha N₂ missing

14.22 kg/ha = .33 (Unknown Quantity of Bulk 33-0-0 fertilizer)

43 kg/ha = Bulk Quantity of 33-0-0 that must also be added.

Required 14.22 = 43.09 kg of 33-0-0 to satisfy the N₂ when furnished N₂ = 33% of bulk.

Now what is the applicable rate per ha?

$$\begin{aligned} & 198.07 \text{ kg of 11-52-0} \\ + & \underline{43.98 \text{ kg of 33-0-0}} \\ = & 241.16 \text{ kg of the mixture per ha} \end{aligned}$$

c. Split-Ball

At 241.6 kg/ha - the bulk spreader has 3990 kg of mixture on the load. How many hectares will this do?

$$\text{SO } \frac{3990 \text{ kg}}{241.6 \text{ kg/ha}} = 16.51 \text{ hectares}$$

d. Fast-Ball

The load (3990 kg total) is a blend of the 11-52-0 and 36-0-0 (Quick Release Nitrogen) and 37-0-0 (Slow Release Nitrogen) in the right proportions. Now how many hectares can the load do?

Add the per unit weights of the two components.

$$241.6 \text{ kg (the contractor's 11-52-0 plus the supplemental nitrogen in the 33-0-0)} + 181 \text{ kg of sulphur coat quick release nitrogen requirement} = 422.6 \text{ kg/ha}$$

$$\text{Then } \frac{3990}{422.6} = 9.44 \text{ hectares of coverage}$$

4. Inspection Considerations

5. Photos Needed

805.00

SOIL AMENDMENT

SSHC References Section 805 – Soil Amendment

Other References

General information

Installation Procedures

Measurement

Inspection Considerations

Photos Needed

806.00

MULCHING

1. SSHC References Section 806 – Mulching

2. Other References

a. Stormwater Pollution Prevention Plan

b. NDOT Stormwater Pocket Guide

3. General information

a. Mulching is required in all areas that have been seeded as an erosion control practice that uses prairie hay or straw to stabilize exposed soils and protect the newly planted seeds. Mulch may also be used without seeding, as a temporary sort duration BMP to protect exposed soils.

While considered equivalent, prairie hay is preferred over straw as it can contain viable seeds. There is a lot of go-down wheat that may be offered for mulch. If it has not been threshed, we do not want it. There are also many CRP acres that have been authorized for haying. Many of these CRP acres were planted in brome grass. Brome grass is not native (prairie) hay and cannot be used on our projects.

- b. Machine printed weight tickets are required for all mulch used. The inspector should receive the weight ticket and obtain a count of the bales at the time the material is delivered to the job site. The average bale weight can then be calculated. A round bale should weigh approximately 1/2 to 3/4 tons.
 - c. The mulch must be certified as "Noxious Weed Free". The certification must occur prior to a field being cut. The following are able to provide mulch certifications:
 - (i) County Weed Authority
 - (ii) Crop Improvement Board Designees
 - (iii) Approved Hay Brokers
 - (iv) NDOT Roadside Development and Compliance Unit staff
 - d. Scale Tickets and Noxious Weed Fee Certifications must be provided to NDOT staff upon delivery.
4. Installation Procedures
- a. All permanent seeding with prepared seed beds are required to be mulched. The mulch shall be "blown" and "crimped in" within 24 hours of the seeding operation.
 - b. The mulch must be applied to the specified areas at the required rate. A mulch blowing machine capable of spreading mulch uniformly is used for applying mulch.
 - (i) Unless specified elsewhere in the contract, mulch must be applied at a rate of 2 tons per acre for hay or 2.25 tons per acre for straw.
 - (ii) Mulch applied as a temporary cover or with cover crop will be placed at a rate of 1 ton per acre.
 - c. Areas inaccessible to a mulch blowing machine may be mulched by hand.
 - d. Immediately after mulch material has been applied, it is anchored with a mulch crimper. Crimp rows should be on the contour when feasible.
5. Measurement
- a. Mulch is measured in tons.
 - b. The weight of the mulch required is calculated by multiplying the measured area by the specified application rate.
 - c. Example Calculation
Example of area to be mulched at the rate of 5 Mg/ha:
Measured area is 2.6 ha, the average mass per bale is 360 kg.

Compute as follows: $5 \text{ Mg/ha} \times 2.6 \text{ ha} = 13 \text{ Mg}$ of mulch required for the area.

Number of bales required: $\frac{13 \text{ Mg}}{360 \text{ kg/bale}} = 36.1$ bales (say 36)

6. Inspection Considerations

- a. The mulch should be applied loose enough to allow some sunlight to penetrate and air to circulate, but thick enough to partially shade the ground.
- b. Proper installation will result in mulch being a uniform cover with the fibers being securely lodged in the soil.
- c. Proper soil preparation is the key to successful mulching. If the soil is too hard or too dry the crimp will be weak and the mulch will not stay in place. Water can be added prior to prepping the seed bed for areas that do not have adequate moisture and larger ripping equipment can be required if the soil is too hard.
- d. Areas that have two foot earth shoulders will require special attention as these are difficult to get proper mulching.

7. Photos Needed

- a. A representative photo of prairie hay and straw mulches.
- b. Proper crimping
- c. A representative photo of 2 tons per acre

807.00 HYDROMULCHING

SSHC References Section 807 – Hydromulching

Other References

General information

Installation Procedures

Measurement

Inspection Considerations

Photos Needed

808.00 SLOPE PROTECTION

SSHC References Section 808 – Slope Protection

Other References

General information

Installation Procedures

Measurement

Inspection Considerations

Photos Needed

809.00 SODDING

SSHC References Section 809 – Sodding

Other References

General information

1. Installation Procedures

The suggested sequence for placement of sod is:

a. Shape Sod Bed

Ditch channels should be shaped in order to obtain a relatively level, flat-bottom ditch which will drain without water ponding. The depth should be a minimum of 150 mm (6 inches) below adjacent ground. Many ditch failures result because the ditch bottom is not level, causing a concentration of flow on one side of the ditch.

b. Apply Fertilizer

Presodding - Two kinds - Inorganic which is typically a 16-48-0 or a 18-46-0 and is available at most any fertilizer dealer and urea-formaldehyde - a 38-0-0 material that is blue in color.

These fertilizers are applied to the prepared sod bed prior to sodding.

Post Sodding - The 16-48-0 or the 18-46-0 applied at the completion of the watering period.

c. Place Sod

Note the quality of sod, making sure it is free of objectionable material (tree roots, brush, stones, etc.) also that it is free of noxious weeds and relatively free of all other weeds and grasses other than bluegrass.

Sod can be placed until the ground freezes at the construction site or at the sod farm.

d. Finish Sod

Smooth disturbed areas along the edges of the sod. Be sure that no ridge of dirt remains alongside the sod ditch, and that the disturbed area is properly shaped and sloped to allow water to run onto the sod.

e. Water

Water the sod within one hour after laying, and sooner on hot days, and thereafter as specified. The amount of water required for sodding varies depending upon soil type, soil moisture, and local weather conditions at the time of sodding. Watering is to saturate the soil. Sod should be watered with a spray, and not much pressure. Too much pressure disturbs the sod and has a tendency to wash the dirt away from its edges.

f. Tamp

Tamp or roll sod as specified if necessary to secure bonding.

Measurement

Inspection Considerations

Photos Needed

810.00 EROSION CONTROL

1. SSHC References
 - a. Section 810 – Erosion Control
2. Other References
 - a. [Approved Products List](#)
 - b. Stormwater Pollution Prevention Plan
 - c. NDOT Stormwater Pocket Guide
3. General information
 - a. Is the selected material from the appropriate category of the [Approved Products List](#)? (Section 810.02, Paragraph 1&2)
 - (i) All rolls of erosion control blanket should arrive at the project with identifying labels.
 - (ii) Only products listed in “Class 1” can be used for the item “Temporary Erosion Control Blanket”
 - (iii) Products that are more durable products than were specified may be used as an alternative. Refer to the “Notes” on the [Approved Products List](#) for acceptable alternatives.
 - b. Does the contractor have the appropriate staples? The standard pin length is 6 inches, however longer or biodegradable pins may be specified through the Special Provisions. (Section 810.02, Paragraph 3)
 - c. Do the seed bags have NDOT tags attached? The inspector should be the one removing the tag prior to use on the project. The tags should reflect the appropriate seed mixture for the application. (Section 810.02, Paragraph 4)
 - (i) There may be multiple erosion control seed mixtures developed for a project. Verify that the appropriate mixture is being utilized.
 - (ii) Follow the seed approval procedures shown in Section 801.
 - d. Has the Contractor provided the correct fertilizer? (Section 810.02, Paragraph 5)
 - (i) Note what was specified in the project’s Special Provisions. Multiple fertilizer rates could apply to the project.
 - (ii) Watch for locations identified in the plan set, where fertilizer may not be applied.
4. Installation Procedures
 - a. Has the finish grade been accepted for the area to receive erosion control?

- b. Is the seedbed properly prepared?
 - (i) This includes the repair of any erosional areas and the removal of any debris, roots, stones, clods larger than 1 inch in diameter.
 - (ii) Temporary vegetation and weeds need to be removed prior to the installation of erosion control blankets
 - (iii) The top one inch or more of the soil needs to be loosened prior to the seeding and blanket installation.
- c. Erosion Control Blanket installation
 - (i) Roll blankets on the prepared soil, after fertilization and seeding
 - (ii) Blankets are typically installed parallel to the direction of flow.
 - (iii) Note in the specifications that Erosion Control "Class 2C" is soil filled over the top and has an Erosion Control "Class 1F" cover.
- d. Typical work sequence
 - (i) Soil preparation
 - (ii) Install fertilizer
 - (iii) Apply seed and incorporate in the soil
 - (iv) Install the erosion control blankets
- 5. Measurement
 - a. The item is measured by the square yard of surface that has been covered
 - (i) When ordering quantities for the project, the Contractor must take into account the required overlaps of material.
 - b. Staples, seed and fertilizer are all subsidiary to the erosion control blanket item.
 - (i) For Erosion Control "Class 2C", additional subsidiary items include soil filling the blanket and covering it with Erosion Control "Class 1F".
- 6. Inspection Considerations
 - a. Ensure that the blankets are flat on the ground and are not "tenting" due to clods, rocks or other debris.
 - b. Verify the staple pattern and spacing between staples.
 - c. Check installation details for proper installation at the edge of pavement.
 - d. Verify proper dimension of overlap of material.
 - e. Check for the installation of check slots in channels. In channel scenarios, there should be a check slot or a silt check approximately every 25 feet.
- 7. Photos Needed
 - a. A representative photo of a Class 1 and Class 2 Erosion Control Blanket
 - b. Check Slot

c. Edge of pavement installation

d. Stapling

811.00 TRANSITION MAT

SSHC References Section 811 – Transition Mat

Other References

General information

Installation Procedures

Measurement

Inspection Considerations

Photos Needed

812.00 SILT CHECKS

SSHC References Section 812 – Silt Checks

Other References

General information

Installation Procedures

Measurement

Inspection Considerations

Photos Needed

813.00 MULCH PERIMETER CONTROL

SSHC References Section 813 – Mulch Perimeter Control

Other References

General information

Installation Procedures

Measurement

Inspection Considerations

Photos Needed

814.00 EARTH AND ROCK CHECKS

SSHC References Section 814 – Earth and Rock Checks

Other References

General information

Installation Procedures

Measurement

Inspection Considerations

Photos Needed

815.00 SILT TRAP

SSHC References Section 815 – Silt Trap

Other References

General information

Installation Procedures

Measurement

Inspection Considerations

Photos Needed

816.00

SILT FENCE

SSHC References Section 816 – Silt Fence

Other References

General information

Installation Procedures

Measurement

Inspection Considerations

Photos Needed

817.00

SLOPE TRACKING

SSHC References Section 817 – Slope Tracking

Other References

General information

Installation Procedures

Measurement

Inspection Considerations

Photos Needed

818.00

SOIL ROUGHENING

SSHC References Section 818 – Soil Roughening

Other References

General information

Installation Procedures

Measurement

Inspection Considerations

Photos Needed

819.00

INLET PROTECTION

SSHC References Section 819 – Inlet Protection
Other References
General information
Installation Procedures
Measurement
Inspection Considerations
Photos Needed

820.00

TURBIDITY BARRIER

SSHC References Section 820 – Turbidity Barrier
Other References
General information
Installation Procedures
Measurement
Inspection Considerations
Photos Needed

821.00

TEMPORARY SLOPE DRAIN

SSHC References Section 821 – Temporary Slope Drain
Other References
General information
Installation Procedures
Measurement
Inspection Considerations
Photos Needed

822.00

DUST CONTROL

SSHC References Section 822 – Dust Control
Other References
General information
Installation Procedures
Measurement
Inspection Considerations
Photos Needed

823.00 STABILIZED CONSTRUCTION EXIT

SSHC References Section 823 – Stabilized Construction Exit

Other References

General information

Installation Procedures

Measurement

Inspection Considerations

Photos Needed

824.00 CONCRETE WASHOUT

SSHC References Section 824 – Concrete Washout

Other References

General information

Installation Procedures

Measurement

Inspection Considerations

Photos Needed

825.00 FURNISHING AND PLANTING OF PLANT MATERIALS

SSHC References Section 825 – Furnishing and Planting of Plant Materials

Other References

General information

Installation Procedures

Measurement

Inspection Considerations

Photos Needed

DIVISION 900

**INCIDENTAL
CONSTRUCTION**

**DIVISION 900
INCIDENTAL CONSTRUCTION**

901.00 FIELD LABORATORIES AND SCALE HOUSES

901.01 DESCRIPTION

1. The Project Manager shall determine if the field laboratories or scale houses furnished by the contractor conform to the requirements of the specifications, supplemental specifications and/or the special provisions. Inspection report forms for the laboratories are available at the district offices.
2. The Project Manager shall require the contractor to furnish, relocate when necessary and maintain the field laboratory or scale house as specified.
3. The personnel using the contractor furnished facility shall use due care in performing their required duties to prevent unnecessary wear and tear on the facility.

901.02 MATERIAL REQUIREMENTS

901.03 CONSTRUCTION METHODS

901.04 METHOD OF MEASUREMENT

901.05 BASIS OF PAYMENT

1. Payment of 100 percent will be made for the field laboratory after it is inspected and approved by the Project Manager. Payment for the field laboratory will not be related to the percent of work performed by the contractor.

902.00 GUARDRAIL AND GUARD POSTS

902.01 DESCRIPTION

1. Guardrail installations are dependent on correct location of shoulder grading, bridge approach paving, and 10:1 (or flatter) approach slope to guardrail. Prior to the start of guardrail installations, these need to be reviewed and verified.
2. If the inspector or the Project Manager observe a variance from plans or specifications, then the contractor should be advised immediately. When situations arise that are not covered by specifications, plans, standard plans, or this instruction, contact the Construction Division or the Standard Plans Engineer in Roadway Design Division.

902.02 GUARDRAIL CHECKLIST

1. Before construction of the guardrail, is the slope from the shoulder line to the guardrail post 10:1 or flatter?
2. Is the alignment correct as shown in the plans?
3. Is the height correct as shown in the plans?
4. High tension cable guardrail should be at the height recommended by the manufacturer.
5. Are laps correct to direction of traffic in nearest lane?
6. Is post spacing correct?

7. Are bolts left out where required according to end treatment manufacturers plans?
(i.e.: rail not bolted to posts 1 and 2 on specific types of end treatment.)
8. Is 8x8 inches plate washer installed correctly (nails)?
9. Are washers in correct locations?
10. Is surfacing/pavement around posts removed and backfilled properly?
11. Are high strength bolts used in bridge connection? (See 903.03)
12. Are delineators in correct locations?
13. Are the posts installed properly (plumb)?
14. Is end anchorage cable tightened? (Remove slack)
15. Are the steel tubes at the correct elevation [less than 4" above soil]?
16. Are the horizontal steel struts between the end post and the 2nd posts on the ground or surfacing?

902.03 MATERIAL REQUIREMENTS

1. The plans, special provisions and specifications will include the material requirements. [Materials Sampling Guide](#) includes the inspection and test requirements for the materials. The field personnel must ensure that all materials used in the work conform to these requirements.
2. The construction inspection for this work includes:
 - a. Checking the plan information with actual field conditions to assure plan information is correct or to modify it as necessary to more closely fit field conditions.
 - b. If changes are necessary, prepare a field checked order list for the contractor's use in ordering the necessary materials. This order list should be prepared in letter form to the contractor and include the following listed items.
 - (i) List stations of guardrail.
 - (ii) Side of project.
 - (iii) Build, remove, reset, etc.
 - (iv) Linear feet (meters) of rail.
 - (v) Type of rail.
 - (vi) Type of end treatment.
 - (vii) Number, type and dimensions for special posts.
 - (viii) Special and/or standard plan numbers.
 - (ix) The mid-span rail support.
 - c. This field checked order list should be prepared and submitted as soon as possible to allow the contractor ample time to obtain the necessary materials prior to the date established for beginning the work.
 - d. The DWR for this work should include:

- (i) Inspection information.
 - (ii) Quantities and summary of quantities.
- e. The Contractor must submit to the NDOT.shopdrawings@nebraska.gov (Construction Division) shop plans on the type of “end treatment” that will be installed. Approved shop plans will be stored in OnBase®. The PM must indicate on the “As-Built” Plans the types of “end treatments” that were installed.

902.04 CONSTRUCTION METHODS

1. Standard plan for Traffic Control Devices for Construction and Maintenance, is a part of all guardrail project plans. Field personnel shall ensure that project traffic (whether local only or traffic maintained condition are in effect) is controlled and workers are protected so this work is performed under safe conditions for all involved. Generally, guardrail work would be considered to require traffic control procedures similar to the situation sketches for minor maintenance of short duration or road repair.
2. W-Beam and Thrie-Beam Guardrail Installation
 - a. Rail Alignment
 - (i) Guardrail will be staked by the field personnel. Stakes will be set at the ends of guardrail locations. The location of end treatments, bridge approach sections, etc. should be marked with stakes.
 - (ii) Rail shall be installed with reasonably smooth vertical and horizontal lines. Kinks in both straight and shop curved sections shall be avoided. Face of rail shall have no protrusions that could catch a vehicle sliding along the rail. The project plans will show how to install the guardrail. Minor adjustments may be made to meet plan requirements.
 - b. Guardrail Posts
 - (i) Posts shall be driven or installed at holes in the surfacing for allowing post movement during impact. Post details on the plans show required backfill materials and correct hole sizes.
 - (ii) Where longitudinal obstructions (electric cables, curbs, etc.) are encountered, 2 or 3 posts may have a maximum of 2 blockouts to provide an offset. We may span 12.5 ft and eliminate one post through the standard W-beam installation. This does not include bridge approach section or end treatment. We could also span 25 ft (7.62 m) with three breakaway posts on each side to avoid using posts in obstructed locations. Plans will show these details. If this cannot be done, obstruction shall be removed or relocated.
 - c. Rail Section Location
 - (i) All prepunched rail sections should be in proper location within each guardrail assembly. This involves sections with 3 feet-1½ inch post spacing, sections with 6 feet-3 inch

(1.905 m) post spacing, and appropriate end treatment section as shown in the plans.

d. Rail Height

- (i) Guardrail installations are constructed with W-beam and thrie-beam rail. The Standard Plans indicate the mounting height is measured from surface of ground at the face of rail to the top of rail.
- (ii) Guardrail height at inlets where the ground slopes for drainage or other locations where the ground surface varies will not meet the plan height. The height should be measured before and after the location of the inlet and the elevation of the guardrail maintained though the inlet location.
- (iii) Guardrail elevation should be maintained when placed in the median or on soil. The height above soil should have a greater tolerance than guardrail built on a shoulder over surfacing.

e. Lapping of Guardrail

- (i) Plans indicate guardrail shall normally be lapped in direction of traffic flow. Plans provide a lapping detail for each type of guardrail installation except:
 - * Where guardrail alignment is curved away (to the right of the near lane of traffic) from centerline (bridge ends or end sections), lap should flow appropriately for the approach vehicles.
- (ii) Keep in mind that the basic principle of lapping has to do with favoring the traffic for which the guardrail is being installed. See Standard Plans.

f. Bridge Connections

- (i) On guardrail attachments to concrete which require a bolt longer than 2 ft (600 mm), 7/8 inch (22 mm) bolt anchors may be epoxy grouted into concrete using threaded insert anchors or other acceptable anchors. The threaded inserts should be cast in the concrete on new and reconstructed concrete bridge rail.
- (ii) All bolts on bridge end connections shall be high strength, galvanized hex bolts. Surface of bolt head should be marked A-325, A449 or have three radial marks at 120° intervals.

g. Guardrail Post

- (i) W-beam and thrie beam guardrail posts – wood and steel – must be able to tip backwards/rotate if the beam rail is to work properly. Care must be taken to ensure compliance with the details shown on the plans regarding surfacing blockout with flowable fill or asphalt behind the posts.

h. End Treatments

- (i) There are two general types of end treatments (Type I & II). Future plans will no longer provide "end treatment" details. Contractors will be required to submit shop plans for the "end treatment" they want to use. The plans will indicate where the end treatment is to be installed and whether Type I or Type II end treatment is required and also the acceptable styles for each "Type".
- (ii) End treatment Type I is generally used on expressways and interstates where the speed limit will be at or above 65 mph. "Type I" will be on a guardrail which is set on a parallel or a 25:1 taper.
- (iii) End treatment Type II is used at locations where the posted speed is under 65 mph. Type II will typically be on guardrail which is on a 15:1 taper.
- (iv) All end treatments including bridge approach sections shall be installed so that the end post sleeve is not more than 4 inches above ground level to minimize the snagging of the undercarriage of a vehicle.

i. End Anchorage

ET 31 notes; Do not attach guardrail to posts 1 & 2 (no bolt thru guardrail at posts 1- the end post & 2 - 2nd from end)

NOTES:

- 1.) DO NOT ATTACH GUARDRAIL TO POSTS # 1 & # 2.
- 2.) THE 5/8" FLAT WASHER IS USED UNDER THE NUT, BEHIND THE POST ONLY. NO WASHER IS USED AT THE RAIL.
- 3.) MANUFACTURER SUGGESTS CUSTOMER TO PROVIDE REFLECTORIZATION OF TERMINAL.

Note from ET 31 plan sheet

902.05 METHOD OF MEASUREMENT

- 1. Final field measurement will not be required when the guardrail is constructed as ordered.

902.06 BASIS OF PAYMENT

903.00 INERTIAL BARRIER MODULES

903.01 DESCRIPTION

- 1. This item is for a permanent installation. Temporary installations are covered in Division 400.

903.02 MATERIAL REQUIREMENTS

903.03 CONSTRUCTION METHODS

903.04 METHOD OF MEASUREMENT

903.05 BASIS OF PAYMENT

904.00 ROCK RIPRAP

904.01 DESCRIPTION

1. Large durable rock materials used to protect slopes near water features.

904.02 MATERIAL REQUIREMENTS

1. Rock Riprap materials are listed on NDOT's [Approved Products List](#) webpage under the Erosion Control category. Check with the M&R Aggregate Lab to verify if quality samples are required to be sent in.
2. Riprap is categorized as Type A, B, or C (smallest to largest). Gradation of material is confirmed visually. Ensure that the material has a good variation of sizes (well graded).

904.03 CONSTRUCTION METHODS

904.04 METHOD OF MEASUREMENT

904.05 BASIS OF PAYMENT

905.00 BROKEN CONCRETE RIPRAP

905.01 DESCRIPTION

1. Same as in section 905 except the material consists of broken concrete pieces.

905.02 MATERIAL REQUIREMENTS

1. Contractor required to break down concrete into pieces as explained in Section 906.02. Material is visually inspected by the Engineer to verify proper sizing and well graded. Samples are not sent in to the M&R Aggregate lab for testing.

905.03 CONSTRUCTION METHODS

905.05 BASIS OF PAYMENT

906.00 GABIONS AND REVET MATTRESSES

906.01 DESCRIPTION

906.02 MATERIAL REQUIREMENT

1. Gabion products must be from NDOT [Approved Products List](#) located under the Erosion Control Category. [Approved Products List](#) - Nebraska Department of Transportation.

906.03 CONSTRUCTION METHODS

1. Follow manufacturer's installation requirements.

906.04 METHOD OF MEASUREMENT

906.05 BASIS OF PAYMENT

- 907.00 CONCRETE SLOPE PROTECTION, DITCH LINING, FLUMES AND DISCHARGE STRUCTURES**
- 907.01 DESCRIPTION**
- 907.02 MATERIAL REQUIREMENTS**
1. Contractor frequently request to substitute fiber reinforcement for the welded wire mesh called for in the plans. Contact the PCC Engineer in M&R for acceptability.
- 907.03 CONSTRUCTION METHODS**
1. Ensure that the reinforcing steel is in the middle of the slab and not on the ground. Use of chairs?
- 907.04 METHOD OF MEASUREMENT**
- 907.05 BASIS OF PAYMENT**
- 908.00 INSTALLING TIE BARS**
- 908.01 DESCRIPTION**
1. This item is meant for the installation of tie bars into existing pavement for pavement widening purposes. It is not meant for installing tie bars in new pavement or as part of concrete repair work. See sections 603 Concrete Pavement and 605 Concrete Pavement Repair respectively.
- 908.02 MATERIAL REQUIREMENTS**
1. Approved grouts are listed on the [Approved Products List](#) under “Non-Shrink Grout.”
- 908.03 CONSTRUCTION METHODS**
1. A strong bond between the grout and existing slab is critical to grip the deformed tie bar, thereby locking adjacent slabs together to prevent separation at longitudinal joints. To achieve a strong bond, the drilled hole must be cleaned well to remove all dust, slurry, and other contaminants. If poor bonding is suspected, pull-out testing may be performed by Materials and Research by request through the PCC Engineer.
- 908.04 METHOD OF MEASUREMENT**
- 908.05 BASIS OF PAYMENT**
- 909.00 RIGHT-OF-WAY AND BARBED WIRE FENCE**
- 909.01 DESCRIPTION**
- 909.02 MATERIAL REQUIREMENTS**
1. See [Materials Sampling Guide](#) for material submittals.
- 909.03 CONSTRUCTION METHODS**
- 909.04 METHOD OF MEASUREMENT**
- 909.05 BASIS OF PAYMENT**

910.00 CHAIN-LINK FENCE

910.01 DESCRIPTION

910.02 MATERIAL REQUIREMENTS

1. See [Materials Sampling Guide](#) for material submittals.

910.03 CONSTRUCTION METHODS

910.04 METHOD OF MEASUREMENT

910.05 BASIS OF PAYMENT

911.00 SPECIAL SURFACE COURSE FOR MAILBOX TURNOUTS

911.01 DESCRIPTION

911.02 MATERIAL REQUIREMENTS

911.03 CONSTRUCTION METHODS

911.04 METHOD OF MEASUREMENT

911.05 BASIS OF PAYMENT

912.00 RIGHT-OF-WAY MARKERS

912.01 DESCRIPTION

912.02 MATERIAL REQUIREMENTS

912.03 CONSTRUCTION METHODS

912.04 METHOD OF MEASUREMENT

912.05 BASIS OF PAYMENT

913.00 SUBDRAIN EARTHWORK

913.01 SUBDRAINS

1. Subdrains are constructed on grading, paving, and structures contracts.
2. Verify in the plans or special provisions if pipe or filter fabric is required. Send in quality samples of aggregate to the M&R Aggregate lab. Perform field gradations at frequency specified in [Materials Sampling Guide](#).
3. Subdrains are used for tile relocations, backslope drains, longitudinal and cross drains under the roadway area.
4. Subdrains are also used with granular blankets to develop a drainage layer in areas where the soil has a high moisture content and poor stability.

913.02 BACKSLOPE DRAINS

1. Backslope drains are used in areas where seepage and/or a slide is possible. Where a water table is perched on a very dense layer, a subdrain is installed at or below the surface of the very dense layer. The flow line is very important in this case. A backslope drain may also be used to drain a sand pocket, again plan flow line is important.

913.03 LONGITUDINAL DRAINS

1. Longitudinal drains are usually installed at the pavement edge to remove any water that accumulates under the pavement.
2. Inspection considerations must include:
 - a. Trench Excavation
 - (i) The trenching equipment must be adjusted and maintained so the trench is excavated to the specified depth. It is important that all of the loose excavated material is removed from the bottom of the trench to minimize settlement of the trench backfill. Trenchers have a metal device on the end of the trencher's boom called a "crumber." The "crumber" is to be adjusted so the loose material is scraped off the bottom and removed.
 - b. Outlets
 - (i) All outlets should be inspected prior to backfilling. The pipe coupling should be inspected to assure proper installation. The flow line of the outlet should be checked for uniform downward grade toward the ditch. All outlets are to be marked with an orange fence post.
 - (ii) Some projects require that existing subdrain outlets be extended, for example, on a shoulder widening project. On these projects, the contractor must remove the existing rodent guard before extending the pipe.
 - c. Porous Backfill
 - (i) Porous backfill material must be in contact with the base of the pavement for the subdrain system to operate correctly. This may require hand work by the contractor. No soil shall remain between the pavement edge and the subdrain trench.

914.00 GRANULAR SUBDRAINS

914.01 DESCRIPTION

914.02 MATERIAL REQUIREMENTS

1. Send in a quality sample to M&R Aggregate lab and perform field gradations of the material for acceptance at the frequency specified in the [Materials Sampling Guide](#). To avoid deductions or removals for non-compliant material, it is best to get a sample tested for quality prior to use.

914.03 CONSTRUCTION METHODS

1. After earthwork and shoulder work is complete, excavate trench according to dimensions in the plans. Need to be sure that granular subdrains tie-in below foundation course if present.

GENERAL INFORMATION

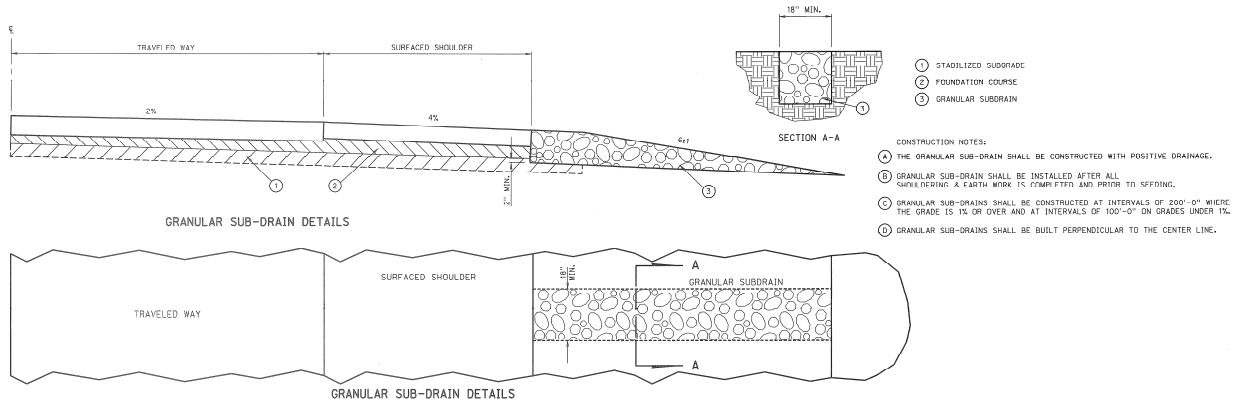

Place granular material and compact by hand.
 Traffic is not allowed near open trench areas until backfilled.

- 914.04 METHOD OF MEASUREMENT**
- 914.05 BASIS OF PAYMENT**
- 915.00 CATCH BASINS, MANHOLES, INLETS, AND JUNCTION BOXES**
- 915.01 DESCRIPTION**
- 915.02 MATERIAL REQUIREMENTS**
- 915.03 CONSTRUCTION METHODS**
- 915.04 METHOD OF MEASUREMENT**
- 915.05 BASIS OF PAYMENT**
- 916.00 RECONSTRUCTION OF MANHOLES AND ADJUSTING MANHOLES TO GRADE**
- 916.01 DESCRIPTION**
- 916.02 MATERIAL REQUIREMENTS**
- 916.03 CONSTRUCTION METHODS**
- 916.04 METHOD OF MEASUREMENT**
- 916.05 BASIS OF PAYMENT**
- 917.00 ABANDONING MANHOLES, INLETS, AND JUNCTION BOXES**
- 917.01 DESCRIPTION**
- 917.02 MATERIAL REQUIREMENTS**
- 917.03 CONSTRUCTION METHODS**

917.04	METHOD OF MEASUREMENT
917.05	BASIS OF PAYMENT
918.00	EQUIPMENT RENTAL
918.01	DESCRIPTION
918.02	EQUIPMENT REQUIREMENTS
918.03	CONSTRUCTION METHODS
918.04	METHOD OF MEASUREMENT
918.05	BASIS OF PAYMENT
919.00	DAMPPROOFING
919.01	DESCRIPTION
919.02	MATERIAL REQUIREMENTS
919.03	CONSTRUCTION METHODS
919.04	METHOD OF MEASUREMENT
919.05	BASIS OF PAYMENT
920.00	MAILBOX POSTS
920.01	DESCRIPTION
920.02	MATERIAL REQUIREMENTS
920.03	CONSTRUCTION METHODS
1.	Follow manufactures instruction for installation of post, footing, and attachment brackets
920.04	METHOD OF MEASUREMENT
920.05	BASIS OF PAYMENT

DIVISION 1000

MATERIAL DETAILS

**DIVISION 1000
MATERIAL DETAILS**

1001.00 GENERAL

1. Specification Division 1000 provides detailed descriptions of the materials specified for highway construction. (Refer to the *Standard Specification for Highway Construction Manual Division 1000* for further material information.)
2. All materials (including those that are subsidiary to another item) should have some type of associated acceptance criteria and often have more than one. The types of acceptance criteria include:
 - a. Visual acceptance by the Engineer (e.g. Burlap for Curing Concrete)
 - b. Certification of Compliance (COC) is a certificate of compliance to a required set of criteria, policy or industry specification (e.g. Buy America certificates)
 - c. Certification of Test (COT) manufacture performed certified testing (e.g. Welded Wire Fabric)
 - d. [Approved Products List](#) (e.g. epoxy compounds and adhesives)
 - e. Sampling/Test
 - f. Department Quality Assurance/Acceptance Testing (e.g. Concrete Pavement Random Coring program)
 - g. Contractor Administered Quality Control/Quality Assurance Sampling and Testing (e.g. Superpave Asphaltic Concrete QC/QA program)

1001.01 SILENCE WITHIN THE SPECIFICATION

1. Some materials may not include the acceptance criteria in the Contract, i.e. the Special Provisions, Standard Specification, Plans, or within the NDOT M&R's [Standard Method of Tests](#) or [Materials Sampling Guide](#) manuals. These materials should be accepted using proper engineering judgment by the Department's technical experts.

1001.02 MATERIAL INADVERTENTLY INCORPORATED

1. Material inadvertently incorporated in the work without the required material documentation should not be included for payment on the progress estimate. If an item is on the estimate, it should be removed until proper documentation is received. If an acceptable post-installation certification cannot be obtained or if a post-installation certification indicates the material is unacceptable, the Lincoln Construction Office should be notified to assist with a determination of acceptance at reduced price or removal and replacement.

1001.03 SAMPLE RECORD

1. A Sample Record must be used to document the acceptance of all material regardless of the type of acceptance criteria used.

1001.04 VISUAL ACCEPTANCE BY THE ENGINEER

1. Visual inspection should be performed by the Project Manager or their designated Construction Technician.

1001.05 CERTIFICATE OF COMPLIANCE (COC)

1. Manufacturer's Certificate of Compliance shall state that the material or item meets all requirements defined for the project. Each COC will include all pertinent data (i.e. size, quantity, specification number, codes, contractor performing work, project number, project location, etc.) for the materials represented by the certificate. An authorized representative of the manufacturing firm will sign the certification.
2. After the material information has been received, the following course of action will be taken:
 - a. The information will be reviewed by State Personnel to insure that it conforms with the material requirements.
 - b. Document the receipt of the certification using the sample record in AASHTOWare Project (aka Site Manager) properly.
 - c. An official copy of the information will be stored electronically in the Department's document management system (OnBase®).

1001.06 CERTIFICATE OF TESTS (COT)

1. Manufacturer's Certificate of Tests shall show the required test results and certify that they are correct. The project number, project location and contractor will be indicated on the COT. An authorized representative of the manufacturing firm will sign the COT. In some instances, such as steel for reinforcement, the process of manufacture must also be shown.

1001.07 APPROVED PRODUCTS LIST

1. Materials identified on the Department's [Approved Products List](#) may be incorporated into the work by notifying the Engineer of the specific brand name that is to be used.
2. Be sure that the product being used is used for its proper application.

1001.08 SAMPLING/TEST

1. This method of acceptance is when a material is accepted based on physical tests characteristics, conducted by a qualified laboratory, as described in the associated material specifications. The testing may be performed by the Department or by the Contractor as defined in the Contract.

1002.00 MATERIAL CERTIFICATION RECEIPT & INTEREST DATE DETERMINATION

1. The interest beginning date is normally the sixty first day following tentative acceptance.
2. If the certifications are not received in a timely manner, then the interest date will be adjusted to the date that the documentation is in NDOT possession. This is why it is extremely important to date the information when it is received from the contractor.

1003.00 APPROVED PRODUCTS LIST

1003.01 DESCRIPTION

1. Many material items are not described in detail in the plans and specifications but are authorized for use as shown on the NDOT [Approved Products List](#). The NDOT [Approved Products List](#) is on file on the NDOT web page and is updated when a new product is added to the list or when a product is dropped from the list.

1003.02 ACCESS COMMANDS

1. Contact [Approved Products List](#) Coordinators in the NDOT Materials and Research Division at (402) 479-4750 if there are any questions concerning the viewing or printing of the [Approved Products List](#).

1003.03 ADDITIONS/DELETIONS TO THE APPROVED PRODUCTS LIST

1. The Approved Products List is normally updated on Friday. Materials that meet NDOT's *Standard Specifications for Highway Construction* may be added to the list at any time. Materials may also be deleted from the list at any time.
2. Contact the Physical Testing Section in the NDOT Materials and Research Division at (402) 479-4746 to obtain information on required certification and documentation that is necessary for a specific product.
3. *SSHC Subsection 1001.03* identifies details relating to the use of the [Approved Products List](#) and the procedure for using a material that is not included on the [Approved Products List](#).

1004.00 WHITE PIGMENTED CURING COMPOUND AND HOT-POUR JOINT SEALER

1004.01 DESCRIPTION

1. White pigmented curing compound and hot-pour joint sealer are sampled at the manufacturer's plant and tested in the Lincoln laboratory before being shipped to Nebraska. Test results for curing compound and joint sealer are on file on the computer. When either of these materials arrive at the construction site, it is necessary to identify the manufacturer and lot number of the material, then check the Approved Products List on the Department's web-site to verify that the material has been tested and approved for use on the project. The possibility always exists that untested material may be shipped to the construction site.

1004.02 REPORTING MATERIAL USAGE

1. If you use white pigmented curing compound or hot-pour joint sealer,
2. Materials and Research verify that the material used corresponds with the following on the [Approved Products list](#):
 - a. manufacturer
 - b. type
 - c. lot number

1005.00 PCC REQUIREMENTS

1005.01 CEMENT CERTIFICATIONS

1. Refer to the NDOT Materials and Research [Materials Sampling Guide](#), Section 28, Policy Number "4" for detailed information on the acceptance criteria for Portland Cement.

1005.02 CONCRETE STRENGTH

1. The following English and Metric unit "Concrete Strength Variation" table is provided to define the different strengths that may be specified. The specified strength has varied as the Department has converted from English to Metric units and then back to English units. In the following table, the standard strengths are given in pounds per square inch (psi) and the various equivalent units that have been used in the past 5 years to specify this strength are shown. However, the strength that a contractor is held-to can only be what is contained in the contract. So if the contract calls for 2900-psi, we cannot reject or deduct if he does not provide 3000-psi.

Concrete Strength Variation

Current Standard Strength (psi)	Actual Specified Strength (psi)	Actual Specified Strength (Mpa)
3000	3000, 2900	20, 20.7, 21
3500	3500, 3625	25, 24.3, 24
4000	4000, 4350	30, 27.6, 27

1005.03 CONCRETE CYLINDER POLICY

1. Cylinders
 - a. All concrete cylinders applicable to this policy will be 4 inches by 8 inches. All cylinders shall be cast by currently certified technicians, or by new or temporary employees trained and approved by qualified Materials and Research personnel in accordance with the NDOT Quality Assurance Program (Section 28 of the [Materials Sampling Guide](#)).
2. Structures
 - a. A set of four 4 inch by 8 inch concrete cylinders for any placement up to 100 cubic yards placed and for over 100 CY three set of four 4 inch by 8 inch cylinders representing each 1/3-day production (refer to Section 16 of the [Materials Sampling Guide](#)).
3. Pavements
 - a. For pavement that is not covered the Random Coring Program, a set of four 4 inch by 8 inch cylinders will be made for each individual placement.
4. Miscellaneous Concrete
 - a. Refer to the [Materials Sampling Guide](#), Section 27, Note 1.

1006.00 MATERIAL & RESEARCH DIVISION'S FINAL REVIEW PROCEDURES

1. The Materials and Research Division's Final Review Section will perform the following steps defined in the Final Review Process Manual; Final Review Process Materials and Research Division – Final Review Section.

DIVISION 1100

ENVIRONMENTAL

DIVISION 1100 ENVIRONMENTAL

1100.01 INTRODUCTION

This Division is provided for information only. It gives you an understanding of the complex laws and regulations that affect environmental issues. You need to be aware of these laws and regulations but you should not advise or direct the contractor regarding "Environmental Issues." However, reporting and recording in the field book all contractor activities is essential.

The phrase Environmental Issues can literally include almost anything from anthropological bones to endangered species, from land use to land disposal, from wetlands to storm water runoff, from wild flowers to underground tanks. For the purposes of this chapter, inferences will be limited to only those issues identified in each section. For this reason, much of the following information contains both general background and specifics. Probably the most important aspects of any environmental issue are:

- * Environmental "issues" are to be taken very seriously. Inappropriate action can result in personal fines "and/or" jail. This is not intended as idle gossip or scare tactics. As a user of this chapter, it is important to know the facts of life.
- * Contact the Construction Division or Project Development with questions, concerns, and observations. If there is a question about whether or not to notify, always make a notification.

"IT IS FAR BETTER TO BE SAFE THAN SORRY!"

Remember, individuals can be held personally liable for not reporting an environmental incident. Through notifying the next higher level, your liability is significantly reduced. While the Construction Division and Project Development may need to refer questions to others, it is important to notify the Construction Division and Project Development so issues can be responded to and tracked.

- * ALL contacts with DEQ, OSHA, and/or EPA shall be made by, or through, the Construction Division. The only exceptions will be when some other office is better able to address the issues. For example: On legal issues, the Attorney General is better suited for a response. The inspector's responsibility is to contact the Project Manager and make a diary entry, the Project Manager is to contact the Construction Division, and the Construction Division will in turn contact the most appropriate office for response. **Remember: Timeliness in responses to a regulatory agency is of the utmost importance.**
- * When the contractor causes an environmental incident, then he/she is responsible to take the appropriate notification and remediation actions. Our inspectors and Project Managers should notify the appropriate people through our chain of command and document the contractor's actions in the field book.

Normal notification chain of command:

- * The Inspector notifies the Project Manager.
- * The Project Manager notifies the District Construction Engineer (DCE)
- * The DCE notifies the District Engineer and the HQ Construction Division.
- * The Construction Division notifies the EPA, DEQ, Attorney General and all other affected agencies.

Emergency notification:

- * First person to see/become aware of an environmental incident should take actions to notify the agency that can contain and mitigate the hazard.
- * Simultaneously as notification is occurring, actions need to be taken to keep workers and public safe.

1100.02 ARMY CORPS 404 PERMITS

The Army Corps 404 Permit process exists in three forms. They are:

1. Nationwide Permit
2. State General Permit (GP77-2)
3. Individual 404 Permit

The Contract Lettings and Communications and Public Policy Division will place a note on the title sheet of plans for projects requiring a 404 Permit (The Materials & Research Division will place such note for projects developed by that Division). The note will identify the kind of permit in use and the identification number (if applicable). Each of the three types of 404 permits require different special provisions. The Contracts Section is responsible for placing the correct set of special provisions in the contract.

1100.03 WETLANDS

Wetlands are a subset of Waters of the United States that is flooded or saturated by surface or ground water long enough to support vegetation typically adapted for life in saturated soil conditions. From a regulatory standpoint, an area is considered a wetland if it has sufficient wetland hydrology (water), has dominant wetland vegetation, and has hydric soils (wet soils).

Waters of the United States do include wetlands, however, they also are identified as rivers, streams, creeks, drainage ditches, and ravines. Basically, any drainage that has some sort of sustained surface flow has potential to be a Waters of the United States.

Mitigation for impacts to wetlands and streams must occur in a specific sequence. The first step of mitigation is to avoid impacts to wetlands or streams. Mitigation projects may include site grading, construction of water control structures, removal of existing drainage features, planting of both uplands and wetlands with native seed, live plugs, and/or trees. It is important for the contractor to understand that mitigation projects often require work in wet soil conditions. One of the most critical elements for mitigation success is construction to the proper elevations.

All mitigation projects should include a discussion of the permit conditions and responsibilities at the preconstruction conference. It is important to invite staff to attend the conference to explain the permit requirements and the responsibilities and obligations of the Department and contractor, as well as to answer any questions.

Occasionally, work may occur beyond that shown on the project plans. If that work affects areas that includes additional impacts to aquatic resources, the Project Manager should contact the Construction Division to ensure permit compliance.

1100.04 WASTED GENERATED

"Solid Waste" means garbage, refuse, rubbish, and other similar discarded solid or semisolid materials, including but not limited to such materials resulting from industrial, commercial, agricultural, and domestic activities. This shall not prohibit the use of dirt, stone, brick, or similar inorganic material for fill, landscaping, excavation, or grading at places other than a sanitary disposal site. It shall be unlawful for any private or public agency to dump or dispose or permit

the dumping or depositing of any solid waste at any place other than an approved sanitary landfill.

"Open Dumping" means the depositing of solid wastes on the surface of the ground or into a stream or body of water.

"Toxic and Hazardous Wastes" means waste materials including, but not limited to poisons, pesticides, herbicides, acids, caustics, pathological wastes, flammable or explosive materials, and similar harmful wastes which require special handling. These items must be disposed of in such a manner as to conserve the environment and be protective of public health and safety.

"Free Liquids" or wastes containing free liquids shall not be disposed of in a sanitary landfill. This includes industrial sludge and toxic or hazardous wastes.

1100.05 CLEAN AIR ACT

Legislation includes air pollutants called Volatile Organic Compounds (VOCs) or sometimes referred to as volatile organic material (VOM). Regulations are aimed at regulating a broad range of coatings. Coatings not only include the obvious paint products, but also include products such as concrete curing compounds, concrete sealers, bond breakers, form release compounds, waterproof sealers, wood preservatives, and several bituminous coatings and mastics. Most of the affected products are items which we accept through some type of supplier pre-certification. Therefore, the Material's Instructional Memorandums will be your source of material related VOC information. If you have specific questions, contact the Construction Division.

1100.06 WATER WELLS

Occasionally contractors request permission to drill water wells on state property in order to secure water to use in the construction of a project. A written agreement should be executed between the state (DEQ) and any contractor who wants to develop a well on state property in order to assure that the contractor assumes responsibility and liability for use of the well.

The Department of Health (DH) has developed rules for plugging and abandoning wells. The rules require that all sealed wells are to be reported by the owner to the DH within 30 days after sealing. They also require a registered well contractor to do the work. This form shall be completed by the contractor and submitted to the Construction Division for forwarding to DH. A copy of the form should be placed in the project file after being completed and signed by the contractor, and registered well contractor. A list of registered well contractors is maintained by DH.

1100.07 ARCHEOLOGICAL AND PALEONTOLOGICAL DISCOVERIES

If Indian relics, fossils, meteorites or other articles of historical or geological interest are encountered in highway excavation operations, such operations shall be suspended in the area involved "until such times as arrangements are made for their removal and preservation".

1100.08 UNDERGROUND TANKS

An Underground Storage Tank (UST) is defined as a tank and associated piping with 10% or more of its volume below the ground which has stored or is storing a regulated substance. Regulated substances include petroleum based substances (motor fuels, motor oil, home heating fuels, solvents, etc.) and any other substance which, if released into the environment may present substantial danger to public health, welfare, or the environment.

Leaks from these tanks or their auxiliary components (i.e., piping, couplings, pumps, and valves) are not uncommon.

Upon finding a previously unknown tank, follow these guidelines:

FIRST: Immediately stop all work in and around the tank.

SECOND: Determine the site conditions. For example:

- A. Note tank condition and damage. Is liquid leaking from the tank? If so:
1. If, based on site conditions and situations, the inspector or contractor feels there is an immediate threat for **explosion**, the contractor shall:
 - Immediately shut-off all operating equipment, extinguish all sources of ignition (i.e., cigarettes etc.) and evacuate the area. This includes all personnel.
 - After the site is evacuated, establish controls to prevent site access and contact local authorities.

The inspector shall contact the Project Manager or Construction Division.

2. If, based on site conditions and situations, the Inspector or Contractor feels there is an **immediate** danger to life or health **other than** by explosion, the Contractor shall:
 - Immediately evacuate the area. This includes all personnel and could include equipment.
 - After the site is evacuated, establish controls to prevent site access.

The inspector shall contact the Project manager or Construction Division.

3. If, based on site conditions and situations, the Inspector feels there is an immediate danger to a water supply, the contractor shall: **(Threats to life or health and explosion are not present.)**
 - Using whatever means are available, immediately establish positive restrictions to limit or prevent migration of contamination to a water supply.
 - Watch for changing conditions which could present threats due to explosion and/or danger to life or health. If site conditions change, implement the appropriate response as noted above.

The Inspector shall contact the Project Manager or Construction Division.

- B. If leakage is not apparent, determine if any liquid is in the tank.
- C. Attempt to determine the size of the tank (volumetric and/or dimensional size estimation).
- D. Is there any indication of past leakage? (Stained soil or smell of fuel are indicators.)
- E. Establish tank location by station, offset, and approximate depth.

THIRD: Begin to establish some positive control to eliminate access to the immediate area. (Silt fence, snow fence, or orange safety fencing set on fence posts are examples of temporary restraints.)

FOURTH: Notify the Project Manager of the discovery and provide site conditions to them. If the Project Manager will not be available for some time (3 to 5 hours), contact the Construction Division directly.

FIFTH: The Project Manager shall notify the Construction Division.

1100.09 STORM WATER DISCHARGE

All NDOT construction projects which disturb 1 acre or more are required to have a STORM WATER PERMIT. (The rules also apply to cities and counties with populations of 100,000 or more.)

Project Manager shall check to assure that projects requiring a Storm Water Permit have a Pollution Prevention Plan (PPP). Along with a PPP there should be bid items for pollution control items such as silt fence, stabilizing crops, ditch checks, etc. As always, it is important to check preliminary plans whenever possible to be sure all needed contract items have been included. Obviously, if a contract is let without erosion control items, the Project Manager will have to change order those items.

1100.10 BRIDGE PAINTING

Testing for lead and chromium (scrape sample) is required for any proposed painting or demolition work. For bridges failing the scratch test (i.e., showing the potential for producing a hazardous waste) a Special Provision (SP) will be written to deal with the added requirements of removal, health & safety, and disposal.

1100.11 ASBESTOS

Asbestos is the name for a group of natural minerals that separate into strong, fine fibers. The fibers are heat-resistant and extremely durable. There are a number of different types of asbestos including Chrysotile, Amosite, Crocidolite, Anthophyllite, Actinolite, and Tremolite. The typical size of asbestos fibers is from 0.1 to 10 micrometers. This makes them usually invisible to the human eye. Because of their fine size, they can remain suspended in air for hours when disturbed. This increases the possibility of human exposure via inhalation.

U.S. EPA regulates the removal of asbestos containing material from facilities which are being demolished or renovated. EPA regulations for removal, and subsequent disposal, are set forth in 40 CFR 61. Buildings and structures that are scheduled for renovation or demolition shall be inspected for the presence of asbestos. This includes bridge projects having the potential to encounter asbestos materials. Note: Moving of a building is considered renovation. Therefore, such instances must be investigated.

1100.12 LIGHT BULBS, THERMOSTATS, & BALLASTS

EPA identifies bulbs and possibly ballasts, transformers, and/or capacitors from the following as regulated waste:

- | | |
|-----------------------------|----------------------|
| Fluorescent lights | Mercury Vapor lights |
| High Pressure Sodium lights | Metal Halide lights |

1100.13 SURFACE WATER

Construction projects involving activities and/or equipment on or near water need to have contingency plans for containment of discharges into or onto the water. 40 CFR 116 defines a discharge as: "Including, but not limited to, any spilling, leaking, pumping, pouring, emitting, emptying, or dumping a controlled material or substance into or onto the water."

Initial reporting shall be to the Project Manager. The Project Manager must relay this information "as soon as possible" to the Construction Division. Be prepared to give the Construction Division specifics like: who, what, where, when, how much, of what and what is being done to contain and clean it up.

1100.14 PROTECTION OF HISTORIC STRUCTURES

The NDOT is required to comply with the National Historic Preservation Act to protect historic structures during construction of transportation projects.

1100.15 ENCOUNTERING HUMAN REMAINS

DIVISION 1300

PROJECT STAKING

**DIVISION 1300
PROJECT STAKING**

1300.01 GENERAL REQUIREMENTS

1. General. Horizontal and Vertical Control. *SSHC Section 114*, Construction Surveying, requires that certain vertical and horizontal control stakes be set for the various items of work to be constructed. This is interpreted to mean the Department will provide the contractor with sufficient intermediate grade and alignment points or stakes, so the contractor can construct the work according to contract documents. Remember the contract plans were created from the preliminary survey, which may be several years old by the time construction starts.
2. Grade and Alignment Stakes. When grade and alignment stakes, including intermediate points, are set by an NDOT survey crew, the Department will be responsible for correctness of staking. The contractor shall be responsible for the correct transposing of data from the construction stakes to the work.
3. Staking. Refer to the Survey Manual coming soon.
4. The Department's ROW Line. The Department's ROW line is not usually placed by registered land surveyors. Therefore, it is not usually a legal description of our boundary.
5. Consultant Survey Data. Consultant survey data must be electronically compatible with NDOT software.
6. Consultant Surveyors. Consultant Surveyors must provide reports of all on site survey activity either in advance of the activity or immediately following the activity so the Department can readily check all stake locations and other survey information provided.
7. Survey Accuracy
 - a. The required accuracy for construction survey staking are as shown in Table 1300.1a.
 - b. The required accuracy for construction survey closures are as shown in Table 1300.1b
 - c. Bench levels, control points, and any significant location should be checked against two known locations.
 - d. All computations should be checked by someone on the survey crew, other than the person who did the initial computation. The check should be done in the field while still on site.

Description	English (ft.)
Alignment (Project) PI's, PT's, etc. and CP's/BM's	0.01
Farmstead Drives	1
Field Entrances	1
County Roads	0.1
Intersecting Highways	0.01
Telephone Poles/Power Poles (offset)	1
Drainage Pipes (Stationing)	1
Length of Pipe	1
Box Culverts (Stationing)	1
Length of Pipe	0.1
Bridges (Stationing)	0.01
Wells (Stationing/offset)	1
Cross-Section Slope Stakes; Rough Grading Stakes; Hub Line	.1
Final Grading (Blue Tops)	.05
Paving Hubs	.01
POT, PI, PC, PT, ETC	0.01

***All locations are to be based on a known location and checked against another known location.**

Table 1300.1B		
Maximum Closure Allowance For Survey Tasks And Activities*.		
(Checking In At A Known Bench Or Other Control Point)		
• Activity	Conventional Survey Methods. (Differential Leveling)	Modern Survey Methods (GPS, Total Station)
Paving Hubs	< or = .05' vertically. (Always adjust out any error encountered on paving grades) Horizontally hubs should always be set sighting thru to the next point, eliminating any error.	The horizontal location may be staked with GPS but vertical elevation will need to be performed using leveling or robotic total station.
Blue Tops	< or = .07' vertically. (Always adjust out any error encountered on blue top grades) Horizontally hubs should always be set sighting thru to the next point eliminating any error in the alignment. Outside hubs should be set pulling a tape perpendicular to centerline.	< or = .07' for vertical closure. < or = to .15' for horizontal closure
Slope Staking	< or = 0.10' vertically. Horizontal alignment is established pulling a tape perpendicular to centerline.	< or = 0.10' vertically. < or = .50' horizontally
Bridges:	< or = .01' horizontally and vertically	It's not recommended that you stake bridges using this method. . As vertical control is not as accurate using trigonometric methods.
Culverts	< or = 0.10' vertically. < Or = to 0.5' horizontally	< or = .10' vertically. < or = 0.5' horizontally
Cross-Sections & Borrow Pits	< or = .15' vertically. < or = 1.0' horizontally	< or = .15 vertically. < or = 1.0' horizontally
Bench Levels	Use formula- .05' multiplied by square root of miles. Any error should be adjusted out thru the entire level run. Use .035' for preliminary bench levels.	It's not recommended that you established benches using this method. . As vertical control is not as accurate using trigonometric methods.
Alignment	< or = .05' horizontally	< or = .05' horizontally
Storm Sewer Systems	< or = 0.05' vertically. < or = to 0.1' horizontally. NOTE: Inlets need to be accurate within a couple of hundreds from centerline to insure proper placement of wall, back of curb and inlet throat.	< or = 0.05' vertically. < or = to 0.1' horizontally.

*All units are represented in feet.

*Note: Under no circumstance should accuracy be compromised. This chart is only to be used as a guide to help you understand the closure tolerance that may be allowed before you need to take the time reviewing your work. These numbers may not fit all situations. If you have any questions it's best to consult with your project manager.

1300.02 CONSTRUCTION STAKES

1. General - Construction Staking

a. Construction surveying represents a large proportion of the construction engineering cost and, therefore, requires study to eliminate all needless refinements. The goal to be reached is a satisfactory project constructed according to the approved plans with a minimum of cost. Centerlines, right-of-way monuments and benchmarks should be established within recognized limits. Other stakes should be established to standards commensurate with their use.

- Rt or Lt is relative to stationing – align yourself looking up to next higher station number to determine left or right.
- The Department usually stakes the ROW as needed for the relocation and location of utilities before the contract is awarded. Utility companies need references to determine how to move their property before the project begins.
- Utilities may damage stakes—communicate the Departments desire to maintain stakes and require utilities to relocate damaged stakes where possible.
- The Project Manager needs to communicate with the Contractor to determine where the contractor plans to start work. With good communication, the Project Manager should be able to accommodate the contractor’s need for stakes within time requirements specified in the contract.
- Today the centerline is generally defined by coordinates however, it is still significant in the majority of the construction staking.
- The survey crew should set the construction stakes as far ahead of the contractor as practicable. The Project Manager must have the area staked sufficiently in advance to avoid construction delays.
The stakes provide the contractor the construction lines and grades and also serve as an inspection guide.
- Stakes must be accurate.
- Keep communication with the contractor open so if a change is necessary, staking will not delay the project.
- The contractor shall be responsible for the protection and integrity of the stakes after placement. The contractor shall take the necessary measures to achieve this.
- All preliminary survey results go to Preliminary Survey Section. Once checked, the data then passes onto Roadway Design and Right-of-Way.
 - ROW surveys are generally done as part of the Preliminary survey. However, the State Surveyor does many of the ROW surveys.

- Hydraulic surveys are also part of the Preliminary survey and the data is provided to Hydraulic Division.
- The Geodetic Survey Section does Photogrammetric surveys. The Photogrammetry Section plots/maps the survey data.
- GPS Pairs are permanent monuments.
 - On each project the Geodetic Survey Section will provide a GPS pair at the beginning, end and generally at one mile intervals along the project.
- The GPS establishes the state coordinate system.
 - HARN was created in 1995 with the help of a National Geodetic Survey, which established a grid of accurate points across Nebraska based on GPS sightings.
 - Coordinates to points are available on [DOTspot](#) or these are also available in OnBase®.

2. Minimum Survey Requirements

Each project is unique and has different survey requirements. Table 1300.2 describes the common stakes. Table 1300.3 explains the definitions of the types of stakes used for construction staking. Table 1300.4 shows the minimum placement intervals for stakes and their approximate location. Finally Table 1300.5 shows how to stake structures (Bridges & culverts).

Table 1300.2 STAKE DESCRIPTION*	
STAKE	DESCRIPTION
Hub (Right of Way)	1" x 2" x 18" (oak) Do not use Rebar.
Hub (Blue Tops)	2" x 2" x 9" (oak) or 1" x 2" x 18"
Hub (Paving Hubs)	2" x 2" x 9" (oak)
Guard Stakes for Marking/Describing Hubs	1/2 " x 2" X18"
Information Stakes For Use in Right of Way, Structures	1" x 2" x 18" (pine)
Slope Stakes	1/2" x 2" x 18" (pine)
Lath (marks hub/guard sites)	1/2" x 2" x 48"
Pink Ribbon	Delineates lath or other objects for visual locating.
Wire Flags – Pink	Marks Bluetops, Paving Hubs, ROW, Structure Stakes, etc.
Rebar	5/8" x 36" Used in establishing control points.
Aluminum Caps	Placed on rebar to accurately establish a given survey point and stamp point information.

*Ground conditions may require other sizes and or types of stakes than those indicated.

STAKE DEFINITIONS Table 1300.3		
DESCRIPTION	PURPOSE	
ROW	<p>1/2" x 2" x 18" hub set at points in the Hub Line where the ROW changes directions (Deflections). Set on PC's, PT's of curves, in Hub Line where tangent sections are over 1,000 feet in length and on hills so ROW may be viewed. Do not use Rebar.</p>	<p>Establishes the boundary breaks of the Department ROW. Right of Way markers are normally installed on these points by the contractor. (Confirm control points before staking ROW.) Or at ROW hub (See example at Subsection 1300.02 C.)</p>
SLOPE STAKES	<p>1/2" x 2" x 18" pine stake with lath (optional) and guard stake (optional) with information describing the limits of rough grading. Set on the extreme outside points of the designed cross section where the grading work and natural ground intersect. Usually set at 100-foot intervals and where changes in slopes, roadway width, sharp curves or ditch dimension change. Slope stakes are protected by a wire flag or lath for visibility.</p>	<p>Defines rough grading requirements – cut/fill, slope, offset from centerline, toe of backslope distance, hinge point/shoulder distance and ditch dimensions. A cut or fill to centerline may be written on the back of the stake.</p>
BLUE TOPS (A Subgrade Lath is sometimes used instead of a Blue Top in cases of extreme subgrade overfill or deficiency with the PM's approval)	<p>2" x 2" x 9" or 1" x 2" x 18" oak/pine Hub stake depending on soil conditions with plain, blue or white colored top. Set the stake at finished subgrade elevation and place another stake (short lath) or wire flag near it for protection. Sometimes colored fiber tail ("chaser") is placed atop the stake to aid grader. Generally the Department will not color the top of the hub or place a fiber tail chaser – that is the responsibility of the contractor.</p>	<p>Used to establish the final subgrade elevations and final grading slopes. These stakes are set centerline; edge of mainline roadway (1/4 points), & edge of shoulder transversely across the roadway. (Additional stakes are needed on multilane highways.) Bluetops are usually set at 100' intervals longitudinally. Additional blue tops may be set at 50' intervals in cases such as vertical curves, sharp horizontal curves, or slope transition areas. Set Blue tops at the exact finish grade elevation—the contractor must make any adjustment.</p>
• PAVING HUBS	<p>2" x 2" x 9" oak/pine hub with a tack set at a contractor specified offset distance from the pavement centerline/edge of pavement. A 1/2" x 2" x 18" pine stake is driven beside the paving hub which explains offset, grade (cut/fill) and station of the paving hub. Usually set at 50' intervals on both sides of the mainline. In cases of sharp vertical curves, horizontal curves over 1 degree, or transition areas, hubs are set at 25-foot longitudinal increments.</p>	<p>Used to set the string line to guide the trimming and pavement-finishing machines. Grade (cut/fill) is indicated on the stake. Need to determine with the contractor whether the offset is level from the edge of pavement or is the projected slope.</p>
DRAINAGE, PIPE, CULVERT, BRIDGE, WALL, DRIVEWAY, CURB, SIDEWALK AND OTHER STRUCTURE STAKES.	<p>1" x 2" x 18" oak/pine Hub set at a specified offset from the structure being staked. A (1" x 2" x 18") pine guard stake which explains offset, grade (cut/fill) and station of the paving hub and a 1/2" x 2" x 48" lath stake is driven beside the hub for visibility and protection. On long pipe runs usually for storm sewers, offset stakes are set at 50' intervals.</p>	<p>Shows the location of structures in terms of project stationing and offset distances.</p>
• SHIM SHOTS	<p>Points on a girder. At locations directed by the Bridge Division. Use a paint mark to mark location.)</p>	<p>Used to determine the final grade of the bridge deck. (Make sure all the Bridge Division knows where on the girder the points were taken.) The actual shim amount is shown with a black marker on steel girders and with paint on concrete girders.</p>
STATIONING LATHS	<p>1/2" x 2" x 48" pine stake (lath). Usually only needed on asphalt overlay projects.</p>	<p>Defines the project stationing. Usually placed before the subgrade is set to help define/establish pavement quantities. Offset near edge of shoulder.</p>
PAVEMENT STAMP	<p>Imprinted station number on pavement. (3" brass number stamps imprints in plastic concrete). Place stamp every 100-feet or 20-meters. Normally place on the right side, progressing up stationing so the stamp can be read from the shoulder. Avoid rumble strip location.</p>	<p>Defines the project stationing.</p>
ALIGNMENT POINTS OR TEMPORARY CONTROL POINTS	<p>May be 5/8" or 1/2" x 36" rebar for permanent points; a 60d spike for a less permanent point; or frequently a 1" x 2" x 18" oak/pine hub with a tack. 1/2" x 2" x 48" pine stake (lath) is used to protect the hub.</p>	<p>Defines the centerline alignment. Such as the beginning or ending of a curve, or the point of deflection of two tangent segments. Temporary Control points may also be offset from the centerline at various locations and are tied to the highway with coordinates.</p>

*MINIMUM SURVEY PLACEMENT INTERVALS						
Table 1300.4						
MAJOR CONSTRUCTION						
TYPE OF STAKE	LOCATIONS	LEVEL GRADE (feet)	HORIZ. CURVES >2 degree (r≤2865') (feet)	HOR. CURVES <2 degree (r≥2865') (feet)	SHARP VERT. CURVES (feet)	OTHER REQUIREMENTS
ROW	Hub, guard and lath set at points in the hub line where the ROW changes direction (deflects). Do not use Rebar.					Set a stake at each break point; on level ground every 1000-feet; at Control points; and at the top of hills to provide Line of Sight and at other locations described in Subsection 1300.02. .
Slope Stakes	Slope stake and wire flag or lath to be set at the extreme outside points of the designed cross section where the grading work and the natural ground intersect.	SS(100')	SS(100')	SS(100')	SS(100')	Changes in roadway width, slopes, ditch dimensions or sharp curves may require additional slope stakes.
Blue Tops	White or blue topped hubs with wire flag or colored fiber tail (chaser) set to final grade elevations across subgrade template. Blue tops may be replaced by subgrade lath if approved by the Project Manager. Only a short lath with cut/fill marked on them is placed on subgrade template.	BT(100')	BT(50')	BT(100')	BT(50')	Blue Tops establish the final grading limits. These stakes are set at centerline; ¼ points; & subgrade/foreslope intersection (edge of shoulder). (Additional stakes may be necessary on multilane roads.)
Paving Hubs	Hubs with guard stakes are set at specified offset distance from edge of pavement.	PH(50')	PH(25')	PH(50')	PH(25')	Offset needed for their equipment. Graded to top of proposed pavement surface. (Level or projected grades as required by the contractor.)
Radius Points and Other Control Points	Locate and verify control points and benchmarks from preliminary survey.	As necessary	As necessary	As necessary	As necessary	Add construction benchmarks and roadway alignment as necessary.

* The frequency of these stakes may not be required if the Contractor is using Automated Machine Guided (AGM) equipment and a data model to construct the project.

PH=Paving Hubs
BT=Blue Tops-Final Grading
SS=Slope Stakes

SURVEY REQUIREMENTS		
Table 1300.5		
STRUCTURES (BRIDGES AND CULVERTS)		
	STAKES LOCATION	
ABUTMENT CENTERLINE	BS (8 each)	Normally two stakes are placed on each side of the bridge at specified distances from centerline of the bridge at each abutment.
WING ENDS	BS (8 each)	Two stakes are placed at specified distances from the end of the wing. These stakes are on the same azimuth as the wing.
PILE LOCATIONS AND ELEVATIONS		Contractor measures from existing stakes to pile locations. Elevations should be verified by the inspector.
PIER CENTERLINE	BS (4 each/pier)	Two stakes are placed on each side of the pier at specified distances from the center of the bridge pier.
GRADE BEAM CENTERLINE	BS (8 each)	Two stakes are placed on each side of the grade beam at specified distances from the center of the bridge.
SHIM SHOTS ON EACH GIRDER	SSR – As Directed By The Bridge Division.	Used to determine the final grade of the bridge deck. (Make sure all the Bridge Division knows where on the girder the points were taken.) The actual shim amount is shown with a black marker on steel girders and with paint on concrete girders.
PIPE CULVERTS	CS (2 each) @ each end of pipe offset as required.	Hub, guard and lath should be placed at a specified offset from the end of the floor on centerline of the pipe, at each end. Any broken back or horizontal break should also be referenced on the end stakes or staked separately.
BOX CULVERTS	CS (2 each) @ each end of pipe offset as required	Hub, guard and lath should be placed at a specified offset from the end of the floor on centerline of the box, at each end. Some contractors may require parapet stakes and wing stakes (mostly on skewed boxes). These should be set at a specified distance to the centerline of the box or end of wing, on the parapet line or wing line. Any broken back or horizontal break should also be referenced on the end stakes or staked separately.
<p>CS=culvert stakes require a hub, guard and lath. BS=bridge stakes may require a hub with nail, information guard and lathe. SSR=shim shot reading</p>		

3. Survey Stake Minimum Requirement Examples — Suggested Format

PAVING STAKES

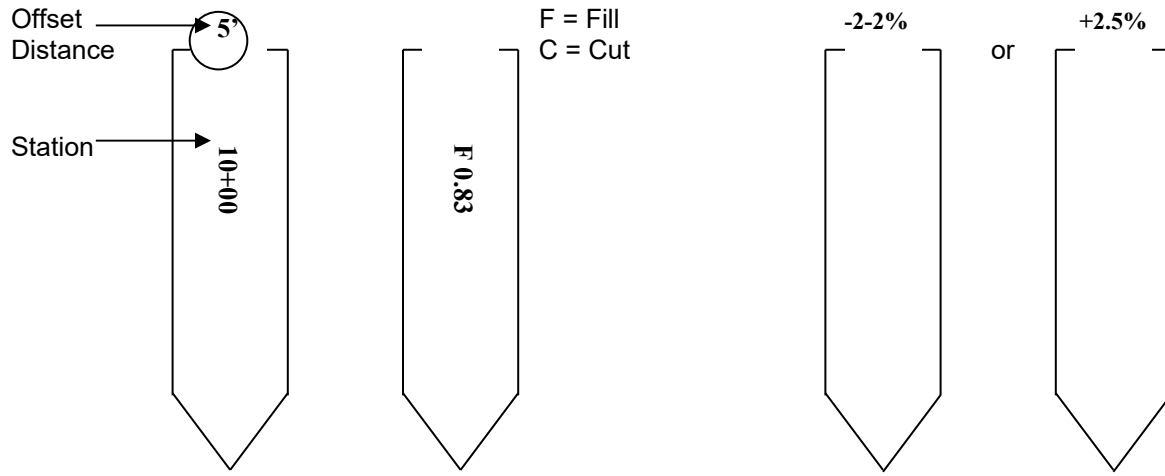

Front

Back

Stakes set at transition points through curves provide changing slope data.

Fill (cut) is to the top of the pavement at outside edge.

Pavement grades may be computed flat from edge of pavement to paving hub, or on projected slope of pavement out to paving hub. Coordinate with contractor for method preferred.

SLOPE STAKES

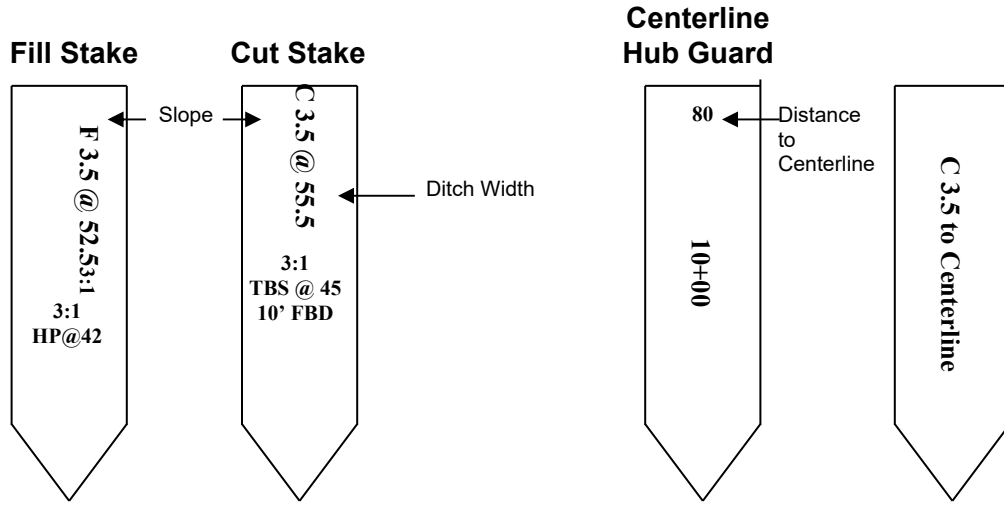

Front

Back

Hinge Point (HP) at 42' from centerline

Toe of Backslope (TBS) 45' from centerline

Centerline reference hub normally set at ROW line. C or F to subgrade elevation at centerline.

On 4-lane road, distance is to A or B Line. Profile point is inside edge of Driving lane.

CULVERT STAKES

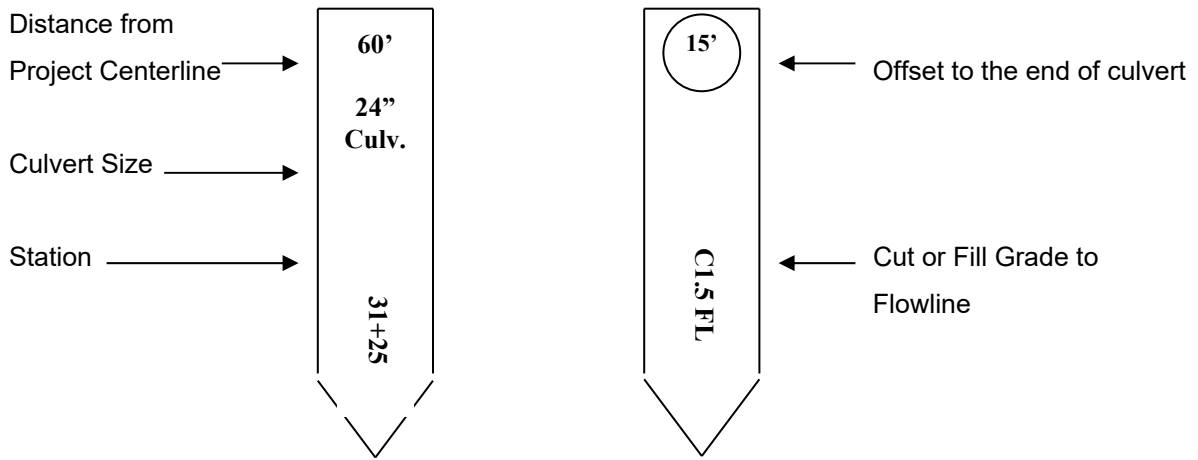

ROW STAKES

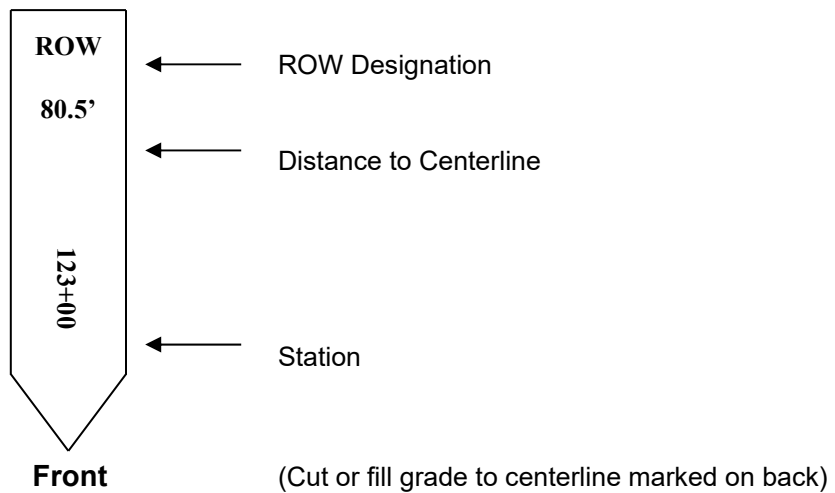

Hub Flags: Green-Yellow flag for easements.
Orange flag for ROW.

1300.03 CONSTRUCTION SURVEY BASIC REQUIREMENTS

1. GeoPak Guidance (Not All Projects Are Available In This Format)
 - a. GeoPak New Project Instructions:
 - (i) Create a new folder on your C: drive under C:\geoprjs\11111; Name this folder with the 5-digit control number for this project. In this example the control number is 11111.
 - (ii) Open Microstation. The Microstation manager window will be on the screen.
 - Set the path on the right to C:\geoprjs\11111.

- Then click file – new. At the bottom of the window select a seed file. Example – C:\users\data\seed3.dgn. Use seed3.dgn for an English survey or mseed3.dgn for a metric survey.
 - Then type the control number in the window on the left side and click ok. The control number 11111.dgn will appear on the top left side of the Microstation manager window. Click ok.
- (iii) The Microstation design screen is now on your screen. The top bar on the screen should read 11111.dgn (3D) – MICROSTATION/J. Click on Applications – GeoPak survey – GeoPak survey tools. The toolbox has four icons.
- (iv) Click on the Project Manager icon. The Project Manager window opens.
- Set the path on the right side to C:\geoprjs\11111. The path appears towards the top of the window.
 - Then click project – new. The create new project window opens. Project name: 11111, Working directory: leave blank, Job number: 111, for the job number use the last 3-digits of the control number. Project description: Skyline Dr.- 204th and Dodge.
 - Now click on preferences. GeoPak user preferences window opens. Direction: Azimuth, Coordinate: XY, Unit: English or Metric. Working directory: leave blank.
 - Then click on feature preferences. Select .smd file, Example- C:\GeoPak_Projects\Standards\prelim.smd or mprelim.smd for a metric prelim.
 - Also toggle on the best match feature. Click ok.
 - Then click ok in the GeoPak user preferences window, and click ok in the Create new project window. An alert window appears asking Create Job 111 in directory C:\geoprjs\11111\? Click Yes.
- (v) In the Project manager window 11111.prj should appear highlighted on the left side of the window. Click ok. The Project users window opens. Click users – new. Name: your initials, Full name: your full name, Op code: your initials, Description: your title or your titles initials, Click ok. Do you wish to define a password for this user? Click No. Highlite (aa) Click ok.
- (vi) Click Survey, The Select Run window opens. Click run – new. The run name should correspond with the letter you used for your Sdms project segment. In this example the run is named tra for the traverse segment. The description can be left blank. Highlite tra. Click ok.
- (vii) The Survey project window opens. The title bar should read, Survey....Project (11111) .. User (aa)..Run (tra).

- (viii) Highlite Data Source, click Single file. The Select sdms window opens.
 - Set the path on the right side of the window to C:\sdms\prj\11111. On the left side of the window the sdms project segments should appear.
 - Select 11111tra.prj and click ok. Toggle on Remove Sdms tag names from point descriptions.
 - Now click sdms to obs. Click on mapping option.
 - Toggle on draw mapping. The Dgn file should read C:\geoprjs\11111\11111.dgn. The seed file is grayed out.
 - Now click control code. Click open. Click 11111tra.ctl. Click ok. The control file should read C:\geoprjs\11111\11111tra.ctl. Coord fields should now have coordinates.
 - (ix) Now click process survey. The standard unit weight should be 3 or less. A larger number indicates a problem with the process of the observations in the obs file and the control file. The Least squares adjustment takes place when processing the survey and creates the reports for review. These are very useful for checking errors and adjustments. Now press any key to continue. Then click import to gpk. This imports the points and chains to a GeoPak database.
 - (x) Clicking on the Bently B and selecting sink can hide the survey project window. You can restore the window by clicking on window – survey project.
 - (xi) To view the project on your screen click fit view. In this example you would see the CP's for this projects traverse.
 - (xii) Continue by opening the survey project window. Click copy run. Select tra. Click ok. Type in the next segment letter and click ok. Proceed with data source as previously explained.
 - (xiii) Roadway Design is developing a program to make setup easier and when this is available it will be easier to use GeoPak.
- b. **Preliminary Cross Section Listings** – This is a tabulation of the preliminary survey elevations and distance. GeoPak has the capability of projecting cross sections at any location.
 - c. **Plotted Cross Sections** – Plotted cross sections are available to the Project Manager for all computer designed projects.
 - GeoPak plots both the preliminary and design cross sections. The scale used for both may be modified to any desirable scale. The scale used is printed in the upper left hand corner of each sheet.
 - d. **Earthwork Computation Listing** – This is a tabulation by stations of areas and volumes.
 - e. The RDS form is titled “**Earthwork Quantities List for Roadways.**”

- f. **Grades and Surfacing Elevations Listing** – This is a tabulation of the finish grades at centerline and at the edge of the surfacing. On horizontal curves all grades have been corrected for transitions and super elevations. GeoPak can furnish grades for any point between the two shoulders.
 - g. **R.O.W. Limit Listings** – This machine listing is discussed later in this subsection.
 - h. **Blue Top Book** – This listing is discussed later in this subsection.
 - i. **Slope Stake Book** – This listing is discussed later in this subsection.
 - j. **Alignment Book** – This listing gives alignment information and is for use when referencing and relocating centerline.
 - Preliminary alignments are available In Roadway Design [(402)-479-4682].
 - Construction Alignments are available through the Roadway Design, Project Designer [(402)-479-4601].
2. Checking Bench Levels
- a. Good bench levels are one of the important reference features of any construction project.
 - b. All benchmarks should be thoroughly checked before any other level work is started. If the preliminary survey party has not established benchmarks at proper intervals, intermediate ones should be set. Permanent benchmarks should be established approximately 1000 ft. apart and also near all major structure locations.
 - c. In choosing objects for benchmarks, the Project Manager must keep in mind that such objects must be permanent and easily accessible. Nails in fence posts and pole lines should be avoided. A 3 ft. “T” post is normally required for a benchmark however, the PM may authorize the use of steel reinforcing rod, at least $\frac{5}{8}$ inch round and 3 ft. long driven 2 inches below ground level in a location that will not be disturbed. The location should be marked with a guide stake or lath and red cloth, and the “plus” and “distance right or left of centerline” recorded in the levels book.
 - d. In running levels, the following rules should be followed:
 - (i) Balance sights. In order to eliminate instrumental errors as much as possible, backsight and foresight distances should be of approximately equal length at all turning points.
 - (ii) Reading the rod. Rod readings at turning points shall be taken to the nearest .005 foot. The rod person shall use a rod plumb or if plumb is not available may wave the rod away from and toward the instrument parallel to the plane of collimation.
 - (iii) Never take down the instrument without checking on a benchmark other than the one used on the setup or turn.
 - (iv) In establishing benchmarks, it is important to turn on each benchmark.

- e. Benchmark notes may be kept in the alignment notebook. Recorded rod readings shall never be erased. If an error is made, a line should be drawn through the erroneous figure and the correct figure written above. In checking elevations, the plan elevations shall be used unless an error in elevation of 0.05 ft. or more is found. If errors are found they should be corrected and documented—some errors will have to be prorated over the intermediate points by the data collector. The final cross section levels may then be corrected to the preliminary datum at preliminary benchmarks or at established benchmarks.
 - f. If difficulty is encountered in checking preliminary bench levels or the Project Manager has reason to believe that an error was made in transferring preliminary elevations onto the plans, the PM may obtain the original preliminary notes by contacting the Roadway Design Division at Lincoln.
3. Reproducing and Referencing Centerline
- a. The construction centerline shall be reestablished using the plan information. It is a good policy to establish the centerline and set the reference stakes for the entire project as early as possible, so that property owners may have ample time to lower pipe lines, remove fences, power and telephone poles, buildings, etc., before the construction crew arrives.
 - b. Transit points that should be verified are:
 - (i) P.O.T. (Point on tangent)
 - (ii) P.I. (Point of intersection)
 - (iii) P.C. (Point of curvature)
 - (iv) P.T. (Point of tangency)
 - (v) T.S. (Tangent to spiral)
 - (vi) S.C. (Spiral to curve)
 - (vii) C.S. (Curve to spiral)
 - (viii) S.T. (Spiral to tangent)
 - (ix) P.O.C. (Point on curve)

(Reference these points to at least four permanent objects which will not be disturbed during construction or shall have coordinates accurate to \neq 0.01 feet. However, in the absence of available “permanent objects”, tacked stakes set at right angles to and at known distances from the project centerline will be satisfactory. Reference ties should be measured horizontally to the nearest $\frac{1}{8}$ ” with a steel tape or tape measurer.)
 - c. After the transit points have been established, proceed to reestablish the centerline markers. The Project Manager should set the centerline markers with an instrument at 100 ft. intervals, measured horizontally on tangents and horizontal curves up to 9400 ft. radius. Curves that are less than radius of 9400 ft. should use 50 ft. chords. The distance “plumbed up” by the chaining crew should be checked occasionally with a hand level or from the difference in old ground elevations shown on the plans.

Intermediate centerline markers on tangents may be set later with a chain stretched between the station markers. Intermediate centerline markers on curves should always be set with the instrument.

- d. When obstructions such as fences, etc. are present on the right-of-way and when the removal of such items are not included in the contract items, the appropriate adjacent property owners shall be notified that they must remove such obstructions. Such notification shall be made well in advance of construction operations so that the owners will have sufficient time to make arrangements for performing the work. They should also be advised of the date on which stakes will be set for their information in removing or relocating their property.
 - e. Provision for the removal of advertisement signs is handled independently by our Right of Way Division. Should any problems arise relative to the removal of advertisement signs, the Construction Division should be contacted.
4. Checking Plan Grade and Calculating Grade Revisions
- a. As soon as possible after assignment to the project, all grade elevations shown on the plan-profile sheets of the plans should be thoroughly checked. This includes percent of grade and vertical curve corrections. On structures, it is recommended that all grades be recomputed including pile cutoff, footing, pier cap, abutment seat, and top of girder elevations.
 - b. It is particularly important to check the profile of the roadway surfacing which connects with the project being constructed. If this elevation is found to differ from that shown on the plans, it is evident that the project grade line will need to be adjusted. This adjustment will cause changes in grade stake elevations and may even affect lengths of proposed culverts in the area.
 - c. If any appreciable error is found between the preliminary and preconstruction chaining or bench levels, and an equation is introduced, it will be necessary to recalculate the centerline grade from the equation point to the next point of intersection of tangent grades, or if too distant, to some nearer convenient point of the next grade break. This is particularly important on concrete pavement as any equation or correction in levels or distance will be reflected in the pavement form elevation.
5. Staking Right-of-Way Fence and Right-of-Way Limit Listing
- a. ROW stakes are needed usually before the contract is awarded to provide references for utility relocations.
 - b. On some projects, right-of-way fence is a contract item and staked and constructed in accordance with the plans or the right-of-way listing. On other projects, fence stakes must be set on the right-of-way line for the guidance of adjacent property owners. The Project Manager should also check the fence setting as it progresses to see that it is set in correct relation to the fence stakes.
 - c. Right-of-way fence stakes should not be set in borrow pits or channel changes until the contractor has these finished to the landowner's and the District Engineer's satisfaction.

- d. Right-of-way limit listings are available for most projects except interstate. Separate listings will be furnished for the left and right sides of centerline of the project. They will give the right-of-way distances at all breaks in the line and at all intermediate full stations. All distances given on the listings are from centerline of the project to the right-of-way line.
 - e. Right-of-way limit information will not be given for segregated parcels near section corners. The listing will give the station and distance to the point where the normal right-of-way enters the segregated parcel and also at the exit, with a break in the stationing between the two. The section corner will not be given. If right-of-way markers are to be set for segregated parcels, consult the plans or the right-of-way contract for the necessary information.
6. Setting Slope Stakes
- a. The "Slope Stake Book" provides the data for locating the slope stakes and this "book"/file is available from the Roadway Design Division.
 - b. Construction stakes are placed on the project before work begins to outline for the contractor the location and extent of the work. Slope stakes may be set with an instrument on projects having the excavation quantity computed from plotted cross sections. The notes shall be kept in a separate book.
 - c. For fill sections, slope stakes are set at the toe of the slope and marked to show the vertical distance and slope from the ground at the stake location to the grade elevation at the hinge point and the subgrade shoulder of the fill.
 - d. For cut sections, slope stakes are set at the top of the backslope and marked to show the vertical distance and slope from the point on the ground where the stake is set to the grade elevation for the bottom of the ditch.
 - e. Slope stakes are normally set on both sides of the road at every station (100-feet); and every 50 ft. on horizontal curves having a radius of 2865 feet or less. Use Type "D" 1/2" x 2" x 18" pine stakes.
 - f. Some intermediate points at which slope stakes should also be set are:
 - (i) P.C. and P.T. of horizontal curves.
 - (ii) Beginning and ending of superelevation.
 - (iii) Points where shoulder and backslope change.
 - (iv) Change in width of roadbed.
 - (v) Change in width of side ditch or borrow.
 - (vi) Any other points helpful to the contractor.
 - g. Balance points shall be well marked on the ground with a lath and red flag. Call the contractor's attention to these points and see that it works for them.
 - h. The plan data pertinent to each station shall be placed in the slope stake notebook. This data gives the trial distance for the first rod reading and

also a check between the plan and the stake as actually set in the field. The information from the plans and the staking data should be similar to the example shown in Appendix 3-12. This example also shows the method for setting stakes for high fills when the instrument height (H.I.) is below the new plan grade.

- i. The staking party should watch drainage along the toe of fill slopes, intercepting ditches, dikes, etc., as the machine does not now provide for drainage in all cases. Where necessary, special ditch grades must be computed in the field. They should also watch for vertical banks just beyond the limits of construction and correct slope stake locations accordingly.

7. Setting Finishing Stakes

- a. The use of a separate notebook, or data collector file, is suggested for the finishing stake (blue top) notes. Several satisfactory methods of keeping notes are presently in use. Following is a description of one acceptable method. The left-hand page of the notebook may be used for the plan data; that is, the station number, the centerline grade elevation, the drop to intermediate points and shoulders, the amount of superelevation on curves, etc. The grade rod, for each point on the grading roadway template to be staked, is computed and placed on this page. The actual level rod reading (Read Rod) can be recorded below the corresponding grade rod and the cut or fill from the existing ground to the grade rod computed. Finishing stakes are then driven at these points and "blue-topped". Only in extreme cases should a cut or fill be marked on the finishing stake. If the grade has been built too high, a hole should be dug deep enough to drive the blue top to grade. The contractor shall be expected to protect these stakes so that they will not have to be reset at some future date. If many stake holes are necessary or many stakes are appreciably high [0.3 ft. and over], additional work should be done by the contractor before stakes are set.
- b. Blue top books are available on all projects designed with the computer. The design information is given for each preliminary cross section on one page with a blank page following for construction information. The elevations included in this information may include an allowance for "trimming". The Project Manager or party chief must determine exactly what elevations are given. When a trimming allowance is not included, up to 0.1 ft. may be added to the elevation of the finished grade stakes.

8. Setting Trimming or Paving Form Stakes

- a. When the roadway is in condition for the surface structure, trimming or paving stakes may be set. They should be aligned and graded by instrument.
- b. The riding quality of the surface structure depends to a large extent on the vertical accuracy of the stakes and the accuracy with which the trimming is performed or the forms are set. The approved method is to set accurate grades to millimeters for each side of the surfacing at a uniform offset (consult the contractor). Grades may be indicated by stakes either driven to grade or driven flush with the ground and marked with a cut or fill. Stakes driven flush are least likely to be disturbed. The alignment shall

be given on one side only and indicated by tacks in the top of the stakes. The appearance of the grade may be checked visually from both directions by sighting along the contractor's string line before the trimming or form setting operation begins.

- c. On curves, the tack line may be run on the offset line after computing a chord length for the offset radius, or the centerline of the curve may be run and the tack line set by double chaining the offset line, again using the proper chord length for the offset radius.
 - d. Stakes are normally set at 50 ft. intervals on tangent alignments and on horizontal curves up to 2° radius which have straight or long vertical curve grades. On horizontal curves over 2° radius and vertical curves having a grade algebraic difference that is more than 1.75 ft. from the tangent grade in 50 ft. , a 25 ft. interval should be used. The ST, CS, SC and TS or PC and PT of all horizontal and the PVC and PVT of all vertical curves should be clearly marked for the contractor. Stake the transitions in and out through the superelevations of the curves as per the Standard Plan.
9. Contractor's Forms on Large Structures
- a. On viaducts and bridges, the staking crew shall give the contractor line and grade on all bents, piers, abutments, walls, etc. This duty will be continuous throughout the duration of the construction. Using the stakes previously set, the Project Manager shall stake or check all pile layouts, centerline, and grade on all footings, columns, caps and anchor bolts before and after the pouring of concrete. Columns, pier caps and anchor bolts should be checked while the concrete is still fresh enough to allow for adjusting the forms or anchor bolts to line and grade. In addition to checking the line from the survey stakes, anchor bolts may also be checked by steel taping form pier to pier. Temperature, force on the tape, and plumbing for elevation must all be considered when this method is used. On steel girder bridges, a final check shall be made on span lengths, pier and abutment angles, and bearing plate seat elevations before attempting to set the girders in place. This should be done as soon as possible to allow time for minor adjustments in the girders should they be necessary. The following steps are used in making this check:
 - (i) From a control point, mark the centerline of the structure on the pier caps.
 - (ii) From a setup using modern equipment, turn the pier angles and mark the centerline of the pier at the center of each set of anchor bolts.
 - (iii) Check the anchor bolts for proper relation to the pier centerlines you have marked.
 - (iv) Steel tape the distance along each line of girders between the abutments and piers as a check on the span lengths. Temperature, pull force, and plumbing for elevation must be accurately used in the measurement.
 - (v) Take elevations on all bearing plate seats. Across any one pier cap the variation from plan elevation between any two bearing seats should not be more than $\frac{1}{4}$ inch. For example, of all bearing

seats across the pier are $\frac{1}{4}$ inch too high (or low), the floor grade can be adjusted to compensate. However, if one bearing seat is $\frac{1}{4}$ inch high and the adjacent seat is $\frac{1}{8}$ inch low, the variation is more than $\frac{1}{4}$ inch and the bearing seat elevations should be adjusted by grinding. This will assure the proper fit of the separator angle against the girder web.

10. Checking Culvert Lengths, Culvert Lists, Slope Stakes, Blue Top Stakes, Paving Hubs, etc.
 - a. General – Another duty of the survey crew is to take cross sections along the centerline of all culvert sites. This includes existing structures which are to be extended as well as proposed structures. The cross section should follow the centerline of the new structure and be taken along the skew line if the structure is not at right angles to centerline. If the inlet or outlet of the proposed structure does not coincide with the flow line of the existing channel or ditch, sufficient rod readings should be taken off-angle [usually extending [200 to 300 ft (60 to 90 m)]] in the existing channel to establish the proper flow line design for the new structure. (The pipes off-line distance, change of skew, and length changes should be noted on the cross section sheets.) The elevation of the intersection of the right-of-way line and existing channel should also be determined.
 - b. The specifications provide that “the contractor shall not order and deliver the (culvert) pipe until a correct list of sizes and lengths is furnished by the Project Manager.” Also, the contractor should not order and deliver material for box culverts, inlets, junction boxes, manholes and similar appurtenances, until a correct list of sizes and lengths of such structures is furnished by the Project Manager.
 - c. The Project Manager should promptly field-check the culvert and drainage structure locations, and prepare the field-checked culvert list. The instructions included herein provide for designing and detailing culvert pipe, reinforced concrete pipe, or corrugated metal pipe in exactly the same manner. This procedure will enable the Project Manager to field check and prepare the “field checked order list” without delaying to determine identity of the contractor and the kind (concrete or metal) of culvert pipe to be furnished. Accordingly, the Project Manager will be able to and should expedite the preparation of the field-checked culvert list to facilitate and provide time for fabrication and delivery of the culvert materials.
 - d. Culvert List – Pipe Culverts – The “field-checked list” of pipe culverts and appurtenances should include the following information for each pipe culvert:
 - (i) Station locations.
 - (ii) Diameter and length.
 - (iii) Kind of pipe culvert (concrete pipe, corrugated metal pipe or culvert pipe).
 - (iv) Type of headwalls, inlet, manhole, junction box, or other appurtenance, and applicable standard plan number or numbers, if such items are to be constructed.

- (v) Degree of skew if culvert is to be skewed, if skewed on one end only, show direction of flow by sketch.
 - (vi) Sketch for each broken back pipe culvert.
 - (vii) Direction of flow for all pipe extensions.
- e. Do not make any field changes to pipe culverts without approval from the designer.

11. Culvert List – Box Culverts

- a. The “field-checked list” of culverts should include all of the following information for each box culvert:
- (i) Station location.
 - (ii) Span, rise and barrel length.
 - (iii) Plan number or numbers.
 - (iv) Height of fill over the box culvert.
- (v) The “field-checked list” should include additional information for each box culvert which is to be constructed on skew, as a broken-back structure, with control joints, or an extension of an existing box culvert, as follows:
- (1) Skew angle if the box culvert is to be constructed on skew, include a sketch if the ends or parapet walls are not to be constructed as shown in the standard plans.
 - (2) A sketch for each broken-back culvert, showing dimensions between the ends of barrel and break points and between break points measured on the axis of the culvert, and showing flow line elevations at ends and at break points.
 - (3) A sketch for each box culvert which is to be constructed with control joints. The sketch should show the dimensions from the ends of the barrel to the first control joint and the spacing between control joints.
 - (4) When the plans provide for the extension of an existing box culvert, the removal of the endwalls and/or the preparation of the existing structure will usually be performed in accordance with details shown in a standard plan.
 - (5) Special plans may be provided for large or complicated structure remodeling. The standard plan includes details for connecting to old structures having angle or straight wings, structures with or without floors between wings, etc. The standard plans also give the contractor the option of doweling into the wings of the existing structure, or breaking back and exposing 2 feet (600 mm) of reinforcing steel to connect the extended structure, when the individual structure plan note does not specify the method of extension.

- (6) In detailing the extensions or remodeling of existing box culvert structures, the Project Manager must include with the field-checked culvert list (1) an adequate description of the existing structure, and (2) an adequate description of the preparation work and extension. This information is essential to the contractor and the fabricator of the necessary reinforcing steel.
- (vi) The description of the existing structure should include:
 - (1) Station location, dimensions (span, rise, barrel length) and type of structure.
 - (2) Plan number if known or available.
 - (3) Type of wing, angle or straight; for straight wings include wing dimensions "L", "C" and "H".
 - (4) Whether or not concrete floors are between the wings.
 - (5) Whether the existing box is suitable for doweling.
- (vii) The description of the new work should clearly describe the preparation work and the extension, and should include:
 - (1) Span, rise and extension length, right and left.
 - (2) The standard plan numbers both for the removal and preparation and for the extension.
 - (3) An adequate description of the removal of endwalls and/or preparation work on the existing structure. Typical examples of the preparation work:
 - (a) "Remove end walls and prepare structure as shown on the Special Plans (in case of special plans for preparation of old structure)."
 - (b) It will be seen that, depending on the type, suitability for doweling and condition of the old structure, the description of the preparation work may include one or more of the typical examples listed. Include a good sketch, with dimensions, for the contractor's (and fabricator's) use when the plan and condition of the existing structure and the new work are difficult to describe in words.
- b. Do not make any field changes to box culverts without approval from the designer.

12. Staking Culverts and Structures

- a. The centerline of culverts shall be indicated by hubs driven on the centerline and offset at such distance from the end of the structure as to protect them from disturbance. The elevation of tops of the hubs above or below the flow line grade at the ends of the culvert should be given, as well as the offset distance [usually 5 to 10 ft (1.5 or 3 m)] from the hub to the end of the new culvert. Guide stakes shall be set in all cases, giving the necessary information relative to the hubs.

- b. Hubs for the alignment of headwalls may be placed on each side of the culvert on the line of the headwall face with the guide stakes clearly indicating the face staked. If the culvert has angling wingwalls, it is suggested that stakes be set marking such angle.
 - c. The centerline of bridges and viaducts may be indicated by hubs driven on the centerline at pier or bent locations and also on centerline of the structure, offset each way from the pier or bent locations. Pier angles shall be turned with a transit and hubs driven on their centerline at such distances as to protect them from disturbance. If possible, three hubs shall be driven on each side of each pier line. Type "E" or specially prepared 2 to 4 inch (50 to 100 mm) stakes, depending on the soil conditions, should be used as hubs to provide stable reference points. All hubs shall be tacked for line and at least two hubs on each side for distance. Since the centerline hubs will usually be destroyed during construction, a based line should be staked both right and left of centerline.
 - d. Permanent benchmarks should be established at each end of the structure and intermediate points as required. All elevations and chaining should be checked and rechecked.
13. Land Survey Monuments
- a. The Department is required by law to notify the county board before undertaking any work that may disturb or destroy any corners of land surveys. It is essential that notification be given the county surveyor so that they will have sufficient time to properly witness all corners before work is begun. In the event that there is no county surveyor, or the county surveyor is not willing to perform the work, the Districts responsibility to schedule a registered land surveyor to perpetuate a monument.
14. U.S. Survey Monuments
- a. Occasionally, benchmarks, triangulation stations, or other monuments of the U.S. Geological Survey or the National Geodetic Survey are located within the limits of construction and must be relocated. Such monuments must not be disturbed until specific permission is received from the director of the survey involved.
 - b. As soon as it becomes apparent that a monument of this type must be relocated, a letter shall be sent to the director of the appropriate survey, stating the necessity for moving the monument giving its designation and requesting instructions regarding the procedure to be followed in moving it. The condition of the monument and its location with respect to section, range, township, county and nearest town should also be included in the letter. The designation consists of letters and numbers stamped with dies on the disk. It is desirable that a rubbing of the disk be submitted also. The address to use for benches and landmarks is:

Director, National Geodetic Survey
601 East 12th Street, Room 1436
Kansas City, Missouri 64106

or

Central Region Engineer
U.S. Geological Survey
Rolla, Missouri 65401

- c. A rubbing may be made by placing a piece of light or medium weight paper over the disk and then rubbing over the paper with a pencil, preferably a hard one, to bring out the legend case in the disk and any letters or numbers stamped on the disk with dies.
- d. Upon receipt of this information, the director will provide for relocation by their forces or will authorize you to move the monument and furnish a new disk to be used in the relocated monument and instruction to be followed in its relocation.
- e. The new monument shall be established strictly in accordance with the director's instructions. The old disk and all notes and information requested shall be transmitted to the director immediately after the monument has been relocated. Extreme care and accuracy shall be exercised in all measurements and work performed and reported so that the accuracy of the original monument may be preserved.
- f. It is important that the necessity for moving such monuments be reported promptly when it becomes apparent that they must be disturbed so that delays in construction work due to waiting for permission and instructions from the directory may be avoided. The work of relocating such monuments should be performed promptly upon receipt of the necessary authorization so that the survey office may have definite information regarding the status of the monument at the earliest possible date.

15. Preserving, Perpetuating and Witnessing Land Survey Monuments
 - a. Preserving Land Survey Monuments – In the course of construction operations, it frequently becomes necessary to remove, or cover with embankments or surfacing, section corners or other land subdivision corners. Due to the fact that so few counties maintain county surveyors, considerable expense is incurred by the department each year in locating corners necessary in acquiring right-of-way. In order to preserve all corners and avoid additional expense in relocating the corners when additional improvements are contemplated, Project Managers are requested to take precautionary steps to preserve all existing corners during construction and to establish permanent markers and witnesses after the work is completed.
 - b. The county board is required by law to “cause to be perpetuated the existing corners of land surveys along the public roads and highways where such corners are liable to destruction, either by public travel or construction or maintenance.”
 - c. In order to comply with the law and cooperate with the county surveyor or Project Manager, the District Engineer will notify the county board in writing at least 120 days prior to construction, listing locations of land survey monuments which are within the construction limits. This notification shall be given on all construction projects including pavement resurfacing (except gravel). Copies of the notification shall be sent to the Deputy State Surveyor in the Roadway Design Division and the Construction Division.
 - d. Where corners have been located by the county surveyor or deputy state surveyor and properly witnessed, it shall be the responsibility of the Project Manager to protect the witnesses during the construction of the project. The Project Manager shall cooperate with the county surveyor by furnishing information regarding the proposed limits of construction so that witnesses may be placed in locations that will not be disturbed. The county surveyor should be notified promptly if it becomes necessary to disturb any witnesses or if witnesses are discovered during construction. Prompt notification in such instances may avoid inconvenience to the county surveyor. The land surveyor who witnessed the land corners prior to construction should be notified. Do not notify deputy state surveyors since they will be unable to return to the project.
 - e. The contractor is required by *SSHC Subsection 107.09* in the specifications to “protect carefully from disturbance or damage all land monuments and property markers until the Project Manager has witnessed or otherwise referenced their location and shall not remove them until directed.” The Project Manager shall cooperate with the contractor and advise of the location of all monuments which have been located and properly witnessed, marking the location of all witnesses by lath or in some other satisfactory manner and advise regarding any other location where monuments have not been located and where particular care should be exercised in excavating to avoid disturbing the monument if it is uncovered.

- f. On resurfacing projects, the written notification directed to the county board shall be considered to have fulfilled the Department's obligation unless the county is not willing or cannot perform necessary work and time and personnel are available to perpetuate known monuments.
- g. In the event that the county does not have a county surveyor or the county surveyor is not willing to perform the work, the Project Manager is responsible to get a registered surveyor from the Deputy State Surveyor's Office to set a temporary witness to preserve the location of all existing land monuments during construction and record such temporary witnesses in the project records.
- h. After construction, permanent corner markers and witnesses can be established to preserve the location of such monuments. Only existing monuments need to be witnessed since lost or obliterated corners have no status unless their location is established by a registered land surveyor. It is anticipated, however, that when right-of-way is acquired, monuments will be found at all land corners since the Right of Way Division is attempting to have the location of all lost or obliterated corners established by the county surveyor or a deputy state surveyor before construction is begun. In order to avoid confusion in the records, it is important that the following instructions be carefully observed.
- i. At some time before construction begins, the county surveyor, if available, should be contacted to determine whether all land corners on the project have been located and witnessed by permanent objects which are on record in their office. If witnesses are shown in the plans, they should be compared with those on record and any errors in the plans corrected. Information omitted from the plans should be entered thereon. The witnesses can then be inspected in the field. If it is found that any of the witnesses have been disturbed, or are within the limits of construction, or are in locations where they cannot be protected during construction operations, the county surveyor shall be requested to establish additional witnesses in protected locations.
- j. If the county surveyor neglects to set adequate witnesses or if a county surveyor is not available and the witnesses shown in the plans have been disturbed or are inadequate, the Project Manager will be responsible to get a registered land surveyor to establish temporary witnesses to preserve the location of all existing corner monuments. These witnesses shall be set in the same manner as that later prescribed for establishing permanent witnesses, except that they may be set in any protected location without specific relation to right-of-way lines.
- k. During construction operations, existing stones or monuments shall not be disturbed unless absolutely necessary. Should construction require disturbing a stone or other government survey monument, the deputy state surveyor in the Roadway Design Division should immediately be contacted before the stone is disturbed. The procedure to be followed in this situation will vary with the situation and the circumstances, however, the deputy state surveyor should be consulted before a government land corner is destroyed. Original monuments which will be under proposed embankments shall not be disturbed and every effort shall be made to protect them during construction operations.

- I. If more than one monument is discovered for a land survey corner, the county surveyor and the deputy state surveyor should be contacted so that they may determine which marks the legal corner. In the event a county surveyor is not available, both monuments should be witnessed and a detailed description of each monument submitted to the Right of Way Division. In such instances, a very careful examination should be made of the surrounding soil for evidence of any deposit originally placed with the monument and charred stakes or pits and mounds which may have existed when the corner was originally established. These descriptions will be submitted to the state surveyor for a ruling as to which monument marks the legal corner.
16. Perpetuation of Section Corner Markers
 - a. After the work on the project is completed, permanent corner markers shall be established. If a county surveyor has not been handling the work, the Project Manager is responsible to schedule the deputy state surveyor to perpetuate section corners using measurements from the temporary witness corners previously set.
 - b. Permanent corner markers set by a registered land surveyor shall be $\frac{1}{2}$ inch (12.5 mm) or $\frac{3}{4}$ inch (19 mm) round steel bars at least 2 ft (600 mm) in length. If monuments are set below paved surface, a hole will be dug each time a corner is needed. Angle irons are also suitable. They shall be driven plumb to an elevation 6 inches (150 mm) below the road or ground surface. Corner markers in bituminous pavement shall be driven to an elevation approximately 2 inches (50 mm) below the surface and any depression filled with bituminous material.
 - c. Corner locations covered by concrete pavement shall be preserved by taking a core and setting the marker in the core hole flush with the surface of the pavement. The hole in the pavement shall be filled with concrete in the same manner as other cores.
 17. Setting Witness Corners
 - a. Permanent witness corners to be set by the Project Manager shall be steel bars, angle irons or old grader blades. Steel bars and angle irons shall be driven flush with the ground surface and marked with an oak guide stake. Grader blades shall be approximately 4 ft. in length and set with 2 ft. of the blade below the ground surface. Witness points shall be set with a transit over the corner to be witnessed. The horizontal distance between the corner marker and the witness shall be measured and recorded. If right-of-way markers are in place, they may be used as witness corners and the section corner tied to the near corner of the right-of-way marker.
 - b. Four witnesses shall be set for each section corner and for each subdivision corner located at an intersection of the project and other roads or streets. They shall be set on the Department right-of-way line not less than 5 ft., back of the right-of-way lines of the intersecting roads or streets. Witnesses for section corners not located at an intersection of the project with another road or street shall be set on the Department right-of-way lines not less than 38 ft. (if possible) from the intersecting landline.

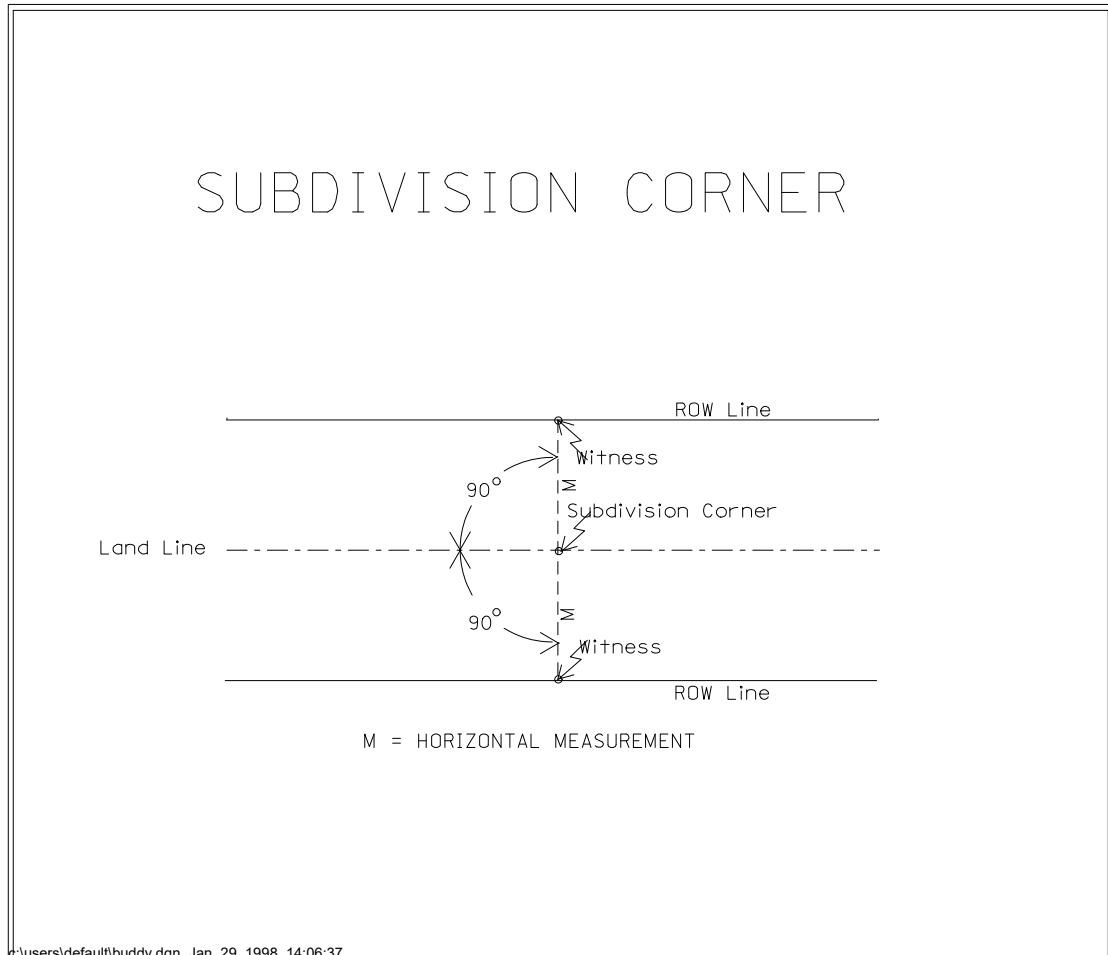

- c. Two witnesses shall be set for each subdivision corner, except those located at an intersection with another road or street. They shall be set on the Department right-of-way lines at right angles to the land.

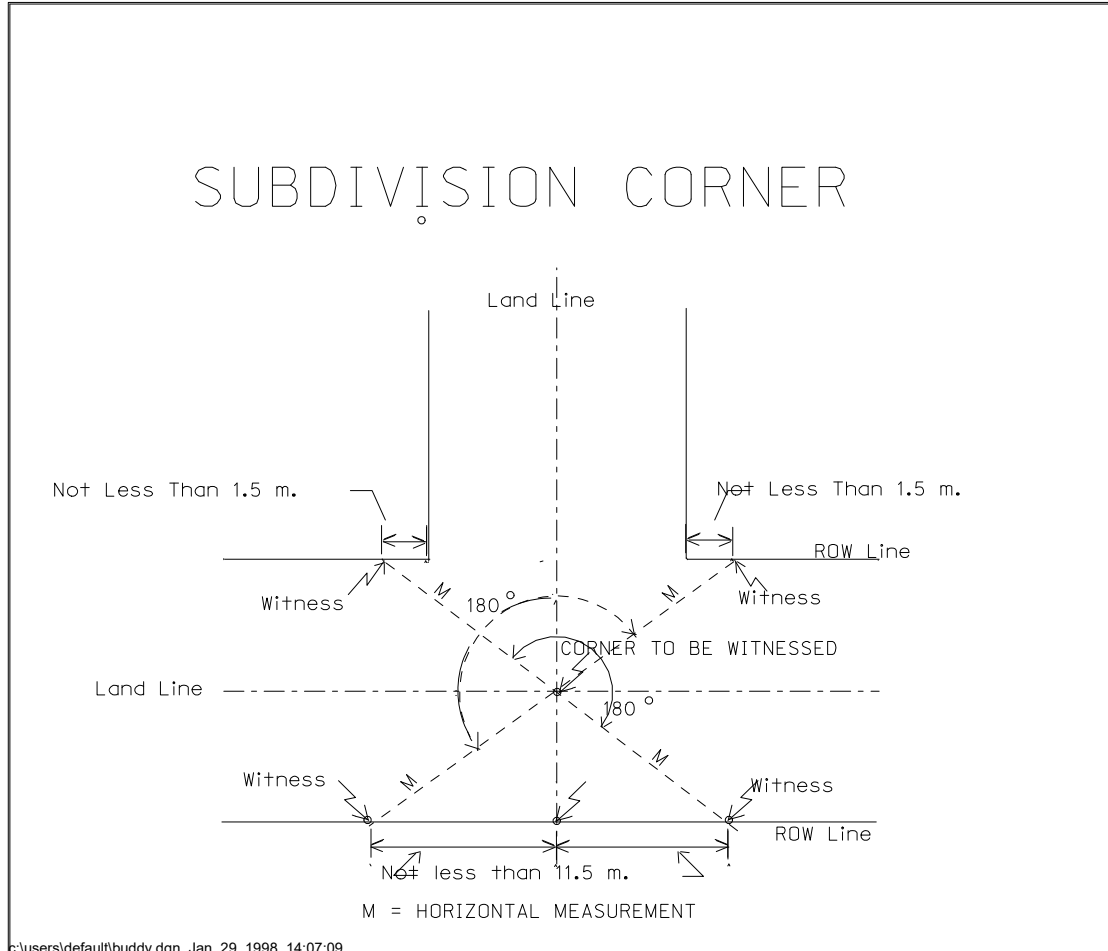

- d. A "Section Corner Tie Sheet" NDOT Form 70 shall be prepared for each corner perpetuated by the Project Manager. Three copies shall be submitted to the Deputy State Surveyor by the Deputy State Surveyor employed by this Department. The Deputy State Surveyor shall forward one of these copies to the State Surveyor, and forward one to the county for their records. Signatures and addresses of two local residents observing the perpetuation of the corner markers and establishment of witnesses should be secured as witnesses. In the event local residents are not present, signatures and permanent addresses of other members of the party shall be secured as witnesses.

18. Installation of Right-Of-Way Markers
 - a. The Department's right-of-way marker is international orange reinforced concrete block. See *SSHC Section 913*.
19. Location of Markers
 - a. Right-of-way markers shall be set accurately on the following points:
 - At each break in the right-of-way line.
 - At apparent intersections of railroad or county right-of-way line.
 - At beginning and end of each curve plus intermediate points on long curves where necessary
 - At apparent intersection of government land lines.
 - At apparent intersection of street right-of-way lines.
 - At lot line intersections if lot corner was in place prior to construction.
 - Refer to Table 1300.4 for stake placement intervals.
 - b. Block corners at city street intersections must be referenced out if available. This will simplify setting a pin on the apparent intersecting street right-of-way line and projecting the new right-of-way line from street to street for proper location of sidewalks or retaining walls.
20. Benchmarks
 - a. During construction of a highway project, many benchmarks may be destroyed and alternate ones must be selected for future use. A permanent benchmark should be established at approximately 1/2 mile intervals along the highway route in rural areas. Bridge abutments are good locations for permanent benchmarks. Headwalls of culverts have also been a favorite place for benchmark locations, but a certain amount of settlement may take place during the first year in a new culvert and may result in erroneous benchmark elevations. Best results can usually be obtained by establishing a benchmark circuit after initial settlement has been completed, normally one year after construction. After elevations are established on the new benchmarks, a NDOT Form 70 should be completed and filed with the survey coordinator or the District office.
 - b. Utility poles, fence posts, ends of drainage pipes, and railroad rails should all be avoided since these objects tend to be disturbed by frost, wind, and farming operations. Casting of a permanent concrete monument within the right-of-way appears to be the best solution in the absence of some other stable, permanent object.
 - c. Establishment of permanent benchmarks should be considered near the end of every major grading and paving project. Monument location should be at the direction of the Project Manager. Occasionally, the Project Manager will have cast-in-place concrete monuments placed by contractor and paid by extra work order. Standard brass shall be provided by the Project Manager to be set in plastic concrete.

- d. Locations for permanent benchmarks in urban areas include fire hydrants, concrete sign bases, and other permanent objects. Interval of benchmarks should be established at about one per city block.
21. Permanent Benchmarks Along Rural Highways
- a. Permanent cast-in-place concrete benchmarks should be constructed using the following guidelines. These should be considered minimum dimensions:
 - Excavate a 8 in. diameter hole 42 in. deep.
 - Insert a #6 English size diameter reinforcing bar in the center of the excavation.
 - Place concrete around reinforcing bar to a depth of approximately 2 inches below ground elevation.
 - Finish concrete so surface is slightly rounded.
 - Insert a brass cap in center of plastic concrete.
 - b. Monument shall be tied to construction centerline by station and distance and recorded on "as built" plans.
 - c. The NDOT Form 70 is required to report and describe all permanent benchmarks on any construction project. "Bridge Plans" include details for placing benchmarks, (brass caps), at bridge ends. (A district file with copies of these forms is recommended.)
 - d. All permanent benchmarks must be tied into the highway reference system and this information included on NDOT Form 70.
 - e. The benchmark's NDOT Form 70 shall be sent to:
 - Nebraska Department of Transportation
 - Project Development Division
 - Preliminary Surveys
 - P.O. Box 94759
 - Lincoln, Nebraska 68509-4759
 - f. A district file of copies of these forms is also recommended.
 - g. A computer file of these permanent benchmarks will be maintained and the highway reference post system will be used to identify the benchmarks.

1300.04 TAKING PRECONSTRUCTION CROSS SECTIONS

- 1. Preliminary Survey Requirements: The designer and the District will work together to determine the "Preliminary Survey Requirements". The requirements can vary for each project.
- 2. When the preliminary survey is put in a Data Collector and loaded onto a computer using current processing software, then preconstruction cross sections can be taken mathematically at any plane.
- 3. Preconstruction Cross Sections. The preconstruction cross sections will, in most cases, consist of additional and extended sections omitted from the preliminary

survey. Cross sections must be taken wherever necessary to show the true excavation quality. Some of these points will include:

- a. Zero sections between cut and fill.
 - b. P.C. and P.T. (T.S. and S.T.) of horizontal curves.
 - c. Points where width of side ditch and borrow changes.
 - d. Points where backslope changes.
 - e. Points where width of roadway changes in cut section.
 - f. Beginning and end of side borrow pits.
 - g. Extending preliminary cross sections where necessary.
4. Cross Section Accuracy. Cross sections shall be taken accurately, at right angles to the centerline, at known locations so that final cross sections may be taken at the same stations. Each section shall be an accurate profile of the ground at that location. All sections shall be taken both left and right of centerline and shall extend at least 10 ft. beyond the construction limits.

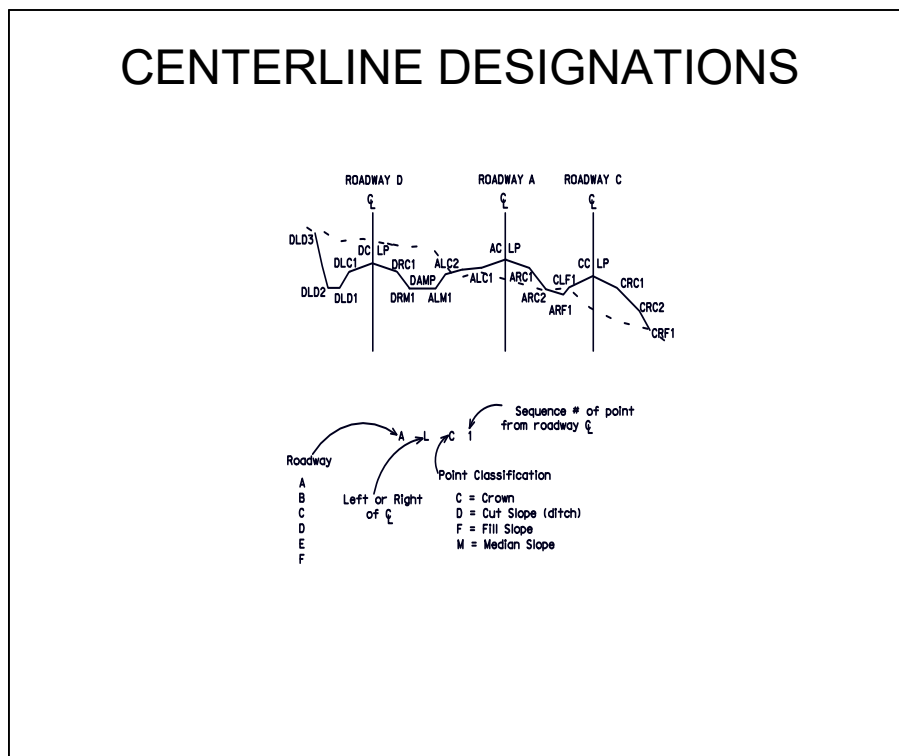

5. Preliminary Cross Sections Used to Compute Final Quantities. When final quantities are to be computed in the field office and the preliminary cross sections are to be used as the preconstruction sections, the Project Manager should request the plotted cross sections by letter to the Construction Division. These cross sections should then be carefully checked to determine that they are of sufficient width to cover the construction limits. Preliminary cross sections are

sometimes extended arbitrarily beyond the actual cross section limits when the project is designed in the Lincoln Office.

6. Intersections. The Project Manager should take preconstruction cross sections on intersections occurring in excavation sections. These cross sections shall be taken at right angles to the intersecting road and may begin at the centerline of the project or at the right-way-way line. In either case, they should “close” on a cross section taken at right angles to the centerline of the project on each side of the intersecting road. The notes should include a complete sketch showing the following:
 - a. The station of the intersecting road or approach road.
 - b. The location of the cross sections.
 - c. Ties to the project centerline and to the approach road line extended.
 - d. Angle of intersection.
 - e. North point.
 - f. Station or plus of project cross sections on which intersecting road cross sections are to “close”.
7. Other Excavation Areas – Channel changes and borrow pits that are not parallel to the centerline of the project shall be cross sectioned separately and tied to the project centerline in a manner similar to that described for intersections. Waste banks shall be cross sectioned if overhaul is involved. They shall be tied to the project centerline and haul routes shown.
8. Cross Section Notes. Notes on intersections, channels, approaches, etc., are usually kept in a separate notebook. Cross section notes should be kept in a manner similar to the example in Division III. Do not crowd the notes.

1300.05 FINAL CROSS SECTIONS AND FINAL QUANTITIES

1. General

As a general rule, final cross sections are not required as long as the contractor has not disputed the plan quantities and any correction made during construction and agreed to accept the plan quantity as the final pay quantity.
2. Final Cross Section Guidance

When final cross sections must be taken, the following is provided as guidance:

 - a. Final cross sections may be taken on each 1 mile as soon as the grading work on that 1 mile section has been completed and accepted. Final cross sections may be taken while awaiting acceptance if the Project Manager is sure there will be no further work which might change the elevation of any excavation cross section.
 - b. Final cross sections must be taken at all points where a preconstruction or preliminary cross section was taken, if excavation was made at that point. If it develops that a final cross section must be taken at some plus station which has no preconstruction cross section, a pre-construction section must be interpolated at that point. The final cross section should extend well beyond the construction limits [5 to 10 ft.]. A rod reading should always be taken on the first definite “natural ground” and this

information recorded in the notebook. In addition, the surveyor must locate all breaks in each cross section and the maximum distance between shots in each cross section is 20-feet.

- c. The excavation involved in undercutting slopes, ditches, borrow pits and shoulders in preparing such areas for the placement of topsoil is not measured for payment and final cross sections shall be taken after the topsoil has been placed.
- d. The Project Manager must clearly separate each borrow pit quantity from one another. If the borrow pit is adjacent to the roadway excavation, the final cross section notes must include a rod reading at the R.O.W. line (shear section) and cross sections for the adjacent borrow pit must be separate from the roadway cross sections and computed separately.
- e. The option pit block on the plans should be stamped participating and at the end of the detailed estimate breakdown of costs for each such borrow pit will appear. The borrow material costs will be computed in the Lincoln Office.
- f. On normal grading contracts, in which no changes in plans are made which would involve overhaul, final cross sections will not be taken for sections which include embankment only. However, when taking the final cross sections for excavation, centerline and shoulder shots should be taken on the embankment at each full station. At locations involving excavation only, or excavation and embankment in the same location, final cross sections shall be taken as necessary to include the excavation.
- g. On linear grading contracts where the plans show a grade line elevation (not county agreement projects), the Project Manager shall take a final cross section at each station consisting of shots on centerline and each shoulder of the finished roadway. This may be done at the time the final check is made on the roadway surface to see that it meets the tolerance set forth in the specifications and/or special provisions, and should be submitted as part of the final records. On projects constructed under agreement by county forces, sufficient checks should be made of the finished grade to substantiate conformance with plans, specifications and special provisions.
- h. Preconstruction surveys for rebalancing, or additional preconstruction cross sections might be necessary to determine pay quantities. Changes in plan or grade line which might involve overhaul cannot be anticipated during design or at the start of work. It is essential that preconstruction information be complete, so that if necessary, the final cross sections may be adjusted to reflect the existing ground elevations at the start of the project if different from the original preliminary cross sections.
- i. When changes in plans involve overhaul, the final cross sections must include all embankment as well as excavation for the balance that the overhaul has occurred in.

3. Earthwork Calculations
 - a. The final earthwork quantities on all in-house projects can be computed/verified via Microsoft/GeoPak or current software. The Finals Section of the Construction Division can assist with or perform these calculations. However, the specific quantities and their location are necessary to verify or calculate quantities. There are two basic ways that projects are surveyed currently:
 - Robotic/Total Stationing
 - GPS Surveying
 - b. Field Notebooks
 - (i) Final Cross Section Notes – A special effort should be made to keep the notes clear and legible. Do not crowd the notes. Not more than four single line cross sections should be recorded on each page of a 4½ x 7½ inch field book. It is suggested that a 3H pencil be used in taking notes.
 - (ii) Notes should be recorded with the stationing reading from the bottom of the page to the top. If there is insufficient room for all readings on one line, the readings should be completed on the next line. The station of each line shall be shown. All shots must be recorded on the proper side of the centerline. See Division III of this manual for example.
 - (iii) Rod readings shall be expressed in ± 1/10 foot on dirt. Surfacing shots will be expressed in 1/100 foot. Use a slightly elevated decimal figure in lieu of a decimal point. All plus rod readings shall be indicated by a plus symbol (+) preceding the reading. Horizontal distances shall be recorded to the nearest 1 ft.
 - (iv) A cross section shall be taken at all equations.
 - (v) Final roadway cross sections may originate on either the right or left side of centerline of the project. The cross section must have a centerline (zero distance) rod reading. This also applies to borrow pits or channels cross sectioned from a base (zero distance) line.
 - (vi) When it becomes necessary to take the final cross sections after completion of the surfacing work, sufficient room shall be left by the note recorder for inserting calculated rod readings. These rod readings will reflect the elevation of the typical grading section shoulder-subgrade point.
4. Width of Preliminary and Preconstruction Cross Sections
 - a. The Project Manager shall check the preliminary cross section data the “Slope Stake Book” and their own preconstruction cross section data to determine whether in all instances these cross sections extend at least as far from centerline as the final cross sections taken at the same locations. In instances where the preliminary or preconstruction cross sections are not as wide as the final cross section, it will be necessary to extend the preliminary cross section using other available information.

5. Plotting Cross Sections
 - a. Microstation/GeoPak may be used in lieu of hand calculations.
 - b. Final cross sections need to be plotted only on those projects not designed under the computer program or those portions of projects (channels, borrow pits, intersections, etc.).
 - c. The final cross sections for excavation only are plotted over the preliminary or the preconstruction cross sections using the same coordinates and drawing in the final with a dashed line.

1300.06 CONTRACTOR FURNISHED CONSTRUCTION SURVEY

1. Construction Staking as Contract Item. On projects with “Construction Staking” included as a contract item, the contractor is responsible for construction staking. The prime contractor may subcontract this item.
2. Additional Survey Work Payment. Additional survey work required because of plan revisions or changes directed by Project Manager shall be paid for as extra work according to *SSHC Subsection 109.05* or be done by the Department.
3. Contractor’s Responsibilities Include:
 - The Contractor’s Surveyor must comply with the minimum requirements in Tables 1300.1 through 1300.5 and all other surveying requirements in this manual.
 - Provide survey data in a format that is compatible with GeoPak.
 - Stake right-of-way, temporary easements, and right-of-entry reference.
 - Preserve and reestablish all centerline control points-point of curve (PC), point of tangent (PT), point of intersection (PI), and point on tangent (POT); and all spiral points (TS, SC, CS, and ST).
 - Establish relocation centerline and related points, including extensions of cross sections, if not established in field by time of advertising for bids.
 - Staking culverts, bridges, sewers and all other structures and pavement requirements.
 - Perform a level circuit to check benchmarks prior to start of construction. Report the results of this survey to the PM immediately upon completion.
 - Stake right-of-way break points.
 - Establish permanent benchmarks and permanent ties to all required points. A copy of all ties must be provided to the Project Manager.
 - Reestablish land corners and section corners. If this is a pay item in the contract then this is a contractor requirement.
 - Section corners are usually reestablished by the county.
 - In rural areas the property corners are usually not reestablished by a registered land surveyor.
 - In urban areas property corners are reestablished by a registered land surveyor and this is a separate pay item.

4. Department Responsibilities:
 - Take elevation reading of settlement plates.
 - Perform work identified in the special provisions of the contract.
5. Special Attention Items
 - a. The Project Manager should be notified and/or consulted for guidance if the following conditions occur:
 - Proposed culvert is staked and its location does not fit existing ground elevations.
 - Conflicting conditions occur such as existing water line located at same location as the proposed sewer line.
 - Farm subdrains are present. Contractor will determine their location, size, and elevation. The Project Manager will establish final size, location, and elevation for construction of tile line to be staked by the contractor.
 - Slope stakes do not match design cross section.
6. Documentation
 - a. Field notes are to be kept in the bound field books. After project completion, field books become the property of the Department.
7. Contract Administration
 - a. By Specification, "construction survey" is identified as a "specialty item."
 - b. "Construction survey" is considered a professional service, therefore Davis-Bacon requirements do not apply.
 - c. If survey work is performed by someone other than the contractor, a "Subcontract Request and Approval" form shall be submitted. All requirements of subcontractors are to be fulfilled with the exception of Davis-Bacon requirements.

1300.07 ENGINEERING EQUIPMENT, SUPPLIES AND SERVICES

1. General

Engineering equipment and supplies are a significant annual expenditure of the Department of Transportation. It is Department policy to maintain equipment in reliable condition, supplies in adequate amounts, and that expenditures be controlled. All employees are expected to support this policy.
2. Responsibility
 - a. The employee is charged with full responsibility for the care of all equipment issued to him/her. The employee should instruct assistants in the proper care and handling of all equipment, particularly the more delicate equipment such as transits, levels, balances, etc. When accepting responsibility for an instrument, whether new or old, the person should inspect it carefully and make sure that it is in good conditions and complete when received. When returning an instrument, all missing or damaged parts should be reported.

- b. The employee is held directly responsible for the loss or damage of equipment in their charge caused by negligence or carelessness and may be required to pay for repair or replacement of this equipment. Equipment when not in use should be stored in a place where it is secure from damage or loss. When equipment is left in an unattended automobile, the vehicle should be locked to prevent theft or damage.
3. Engineering, Surveying and Testing Equipment

A supply of this equipment is maintained at Operations. Equipment will be issued directly to the employee as ordered and approved by the District Engineer or Division Head. Equipment which is no longer needed should be returned to the Operations Division.
4. Requisition And Transfer
 - a. The following example cases are given to explain the procedures to be followed. If your question is not answered, contact the Operations Division.

Case I - Requests for Engineering, Surveying and Testing Equipment listed in the Department's Statewide Inventory System (SWIS) and included in the Supply Catalog in Class 59, are non-stocked items and must be budgeted by districts and purchased by the Operations Division, Engineering Equipment Section.

Case II - Requests for Engineering, Surveying and Testing Equipment not listed on the Department's SWIS and included in the Supply Catalog in classes other than Class 59 will be ordered on a NDOT Form 146, Stock Requisition. Equipment not included in the Supply Catalog will be purchased on a NDOT Form 151, Purchase Order. It will be coded in the District/Division ONE and Activity 5099.

Case III – Material Sampling and Other Miscellaneous Supplies, sacks, cans, molds, lath, stakes, nails, field books, cloth, etc. included in the Supply Catalog will require a NDOT Form 146, Stock Requisition. Items not included in the Supply Catalog will require a NDOT Form 151, Purchase Order. These are “direct purchase” items and are to be charged to specific projects. “O” for participating, “I” for nonparticipating, the OE code for your District/Division and the appropriate activity (Constructing, Design, etc.).

Case IV – Office Supplies, Safety Gear and Medical Supplies included in the Supply Catalog will require a NDOT Form 146, Stock Requisition. Items not included in the Supply Catalog will require a NOT Form 151, Purchase Order. These items are not “direct purchase” items and are to be charged to OE code for your District/Division and Activity 5099. Safety equipment is coded to AFE Y500.

Case V- Transfers of Engineering, Surveying and Testing Equipment listed on the Department's SWIS between Divisions, Districts or returned to Operations will be documented on NDOT Form 332, Furniture and Equipment Issue/Transfer. A NDOT Form 332 must accompany the equipment transferred. Operations Division will always receive the original. The transferee, transferor and the Districts or Divisions will all receive copies. The transferee is responsible for submitting this form.

Case VI – Transfer of Engineering, Surveying and Testing Equipment not listed on the Department’s SWIS and in classes other than 59 to Operations will require a NDOT Form 147 for cataloged equipment and a NDOT Form 147a for non-cataloged equipment. A copy of the form will accompany the equipment. OE code for your District/Division and Activity 5099 will be used.

- b. All forms except the copies required to accompany the equipment will be routed through the District/Division Office and then to the Operations Division.
5. Precautions and Maintenance of Survey Equipment
- a. Robotic/Total Stations (Precautions)
 - (i) Never place the Total Stations directly on the ground. Avoid damaging the tripod head and centering screw with sand or dust.
 - (ii) Do not aim the telescope at the sun. Avoid damaging the LED of the EDM.
 - (iii) Protect the Total Stations with an umbrella against direct sunlight, precipitation, and humidity.
 - (iv) Never carry the Total Station on the tripod to another site.
 - (v) Handle the Total Stations with care. Avoid heavy shocks or vibration.
 - (vi) Always switch the power off before removing the standard battery.
 - (vii) Remove the standard battery from the Total Station before putting it in the case.
 - (viii) When the Total Station is placed in the carrying case, follow the layout plan.
 - (ix) Make sure that the Total Stations and the protective lining of the carrying case are dry before closing the case. The case is hermetically sealed and if moisture is trapped inside, damage to the instrument could occur.
 - (x) Someone should always be near the instruments when it is set up in the roadway or in any other location where it may be disturbed.
6. Total Stations (Maintenance)
- a. Wipe off moisture completely if the instrument gets wet during survey work.
 - b. Always clean the instrument before returning it to the case. The lens requires special care. Dust it off with the lens brush first, to remove minute particles. Then after providing a little condensation by breathing on this, wipe it with a soft clean cloth or lens tissue.
 - c. Do not wipe the displays and keyboard or carrying case with an organic solvent.
 - d. Store Total Stations in a dry room where the temperature remains fairly constant.

- e. If the battery is discharged excessively, its life may be shortened. If it is stored, it should have somewhat of a charge in it.
 - f. Check the tripod for loose fit and loose screws.
 - g. When removing the Total Stations from the carrying case, never pull it out by force. The empty carrying case should be closed to protect it from moisture.
 - h. Check the Total Stations for proper adjustment periodically to maintain the instrument accuracy.
7. Electronic Digital Theodolite/Transit (Precautions)
- a. When the theodolite/transit is not used for a long time, check it at least once every three months.
 - b. Handle the theodolite/transit with care. Avoid heavy shocks or vibration.
 - c. If any problems are found with the rotatable portion, screws or optical parts (e.g., lens) send it in to the Engineering Equipment Shop.
 - d. After removing the theodolite/transit from the carrying case, close the case to exclude dust and moisture. Never place the theodolite/transit directly on the ground. (Attached dirt may damage the base plate and centering screw.)
 - e. Never carry the theodolite/transit on the tripod to another site.
 - f. Protect the theodolite/transit with an umbrella against strong sunlight and precipitation of any kind.
 - g. When the operator leaves the theodolite/transit, the vinyl cover should be placed over the instrument.
 - h. Always switch the power off before removing the internal battery on the theodolite.
 - i. Make sure the theodolite/transit and the protective lining of the carrying case are dry before closing the case. (The case is hermetically sealed; if moisture is trapped inside, damage to the instrument could occur.)
 - j. Someone should always be near the instrument when it is set up in the roadway or in any other location where it may be disturbed.
8. Electronic Digital Theodolite/Transit (Maintenance)
- a. Wipe off any moisture if the instrument gets wet during operation.
 - b. Always clean the instrument before returning it to its case. The lens requires special care. Dust it off with the lens brush first, to remove minute particles. Then, after providing a little condensation by breathing on the lens, wipe it with a soft, clean cloth or lens tissue. (Theodolite only) when cleaning the display, keyboard and carrying case, never use any organic solvent (e.g., thinners).
 - c. Store the instrument in a dry room where the temperature remains fairly constant.
 - d. Check the tripod for loose fitting and loose screws.

9. Survey Levels (General Precautions)
 - a. Be sure to carry the instrument to the job site in the plastic case.
 - b. Handle with care.
 - c. Do not place the instrument directly on the ground.
 - d. After taking the instrument and accessories out of the plastic case, be sure to close the case cover to keep out dust and dirt.
 - e. Use both hands to hold the instrument when carrying it at the job site. Remember that when moving the instrument from one job site to another, it must be removed from the tripod for transporting.
 - f. If the instrument is left mounted on the tripod for any length of time, cap the objective lens and cover the entire instrument with the vinyl cover.
 - g. Be careful not to expose the instrument to direct sunlight and precipitation. If it gets wet, wipe it with a dry cloth before putting it back in the plastic case.
 - h. Store the accessories in the specified places in the case.
 - i. Use neutral cleanser or water to clean up the plastic case.
 - j. Someone should always be near the instrument when it is set up in the roadway or in any other location where it may be disturbed.
10. Survey Levels (Maintenance)
 - a. Moisture affects the surveying instrument. Completely wipe off any moisture if the instrument gets wet during surveying work.
 - b. After use, clean every part of the instrument before putting it back in the case. Breathe on the lens to moisten them and gently clean them with a lens cloth, a clean cloth (preferable, worn out cotton), or soft tissue paper.
 - c. The tripod shoes may become loose or the legs may become shaky due to faulty wing nuts when used for a long period. Check them periodically.
 - d. If foreign matter appears to have entered any movable parts or screws or when condensation or fungi appears on the lens, prisms, etc., in the telescope, put on work order and send in to Engineering Equipment Shop.
 - e. It is recommended to subject the instrument to annual or semi-annual checking and inspection to maintain the high quality necessary for your surveying work.
11. Adjustment of Instruments
 - a. All instruments issued to Project Managers should be in proper adjustment when received from the Lincoln Office. They should, however, be checked for accuracy and necessary adjustments made at regular intervals. Adjustments should be made only by the Project Manager or a qualified member of the party who had been authorized by the Project Manager to perform such work. All adjustments should be carefully made strictly in accordance with methods prescribed in surveying handbooks.

Any adjustment which requires dismantling must be made in the Lincoln repair shop.

- b. All Total Station adjustments should be made in the Lincoln repair shop.

12. Transporting Equipment

- a. Surveying equipment should be loaded into cars or trucks in such a manner as to minimize the possibility of damage. Leveling rods, range poles, etc., are easily damaged by rubbing or scratching against other objects. It is suggested that a holder be installed on the car for each of these articles. Level rods should be kept in a canvas case which may be ordered from Operations.
- b. Transits and levels should be carried in their cases when being transported by car or truck over any appreciable distance. It is good practice to provide a special protected holder within the vehicle for these cases. Instruments may be carried out of case over short distances if carefully held in someone's lap.
- c. Equipment shall be placed in or on vehicles in the most "safe" position both for the equipment and for the operator and passengers of the vehicle. Employees are encouraged to conceive safe methods of transporting equipment. Any alterations, etc., to the vehicle must be made only with the approval of the District Mechanic.

13. Damaged Equipment

- a. All damaged equipment listed in the Department's Statewide Inventory System missing (lost or stolen) is to be reported on NDOT Form 159.
- b. Damaged equipment, especially surveying instruments, should not be used or motions tested to determine the extent of damage until it has been inspected by an authorized vendor. This precaution is necessary for the reason that all damage to the instrument may not be visible. For example, after an instrument has had a fall, the delicate graduated edges of the plates may be seriously damaged by the slightest movement of the plates.
- c. All damaged equipment, together with all worn or broken parts, should be promptly shipped to the appropriate vendor for repair. Equipment returned to the Operations Division for repair, adjustment or exchange must be accompanied by NDOT Form 124, Shop Work Orders. The action desired must be described on this form. The appropriate OE and Activity Coding shall be shown.

14. Shipping

- a. If at any time it becomes necessary to ship an instrument, it should be packed securely in its case and arrangements shall be made through the District Construction Engineer for the transfer of the instrument to Lincoln. Total stations and electronic theodolites should be by truck or car and not be shipped.
- b. Other equipment shall be carefully packed in the cases provided for that purpose. If cases are not provided, the equipment should be packed in a box or carton of ample strength for protection during shipment. All

equipment should be sent to Lincoln in the same manner as transits and levels.

15. Care of Equipment

- a. Cloth tapes, pie-tins and other items of similar nature are considered to be expendable equipment for the reason that they depreciate rather rapidly with normal use. The fact that these items are expendable does not relieve the employees of the responsibility for their proper care and conservation.
- b. Rods and range poles shall be carried in protective coverings or in holders which prevent marring and scratching. To avoid breakage, they should never be used for any purpose except that for which they are designed.
- c. Chains are easily damaged by kinking and by the action of traffic. When practical, a cloth tape should be used instead of a chain, especially if measurements are being made across the line of traffic. When wet or muddy, chains should be cleaned and dried before rolling. They should be cleaned, oiled and inspected occasionally and all kinks removed by hammering on a flat wood surface.

16. Supplies

- a. The Department policy is to have central procurement of supplies. The Supply Catalog lists the items usually stocked. The Supply Catalog can be accessed via computer terminal. Items not listed in the Supply Catalog may be ordered on NDOT Form 151, "Purchase Order". Be sure and list adequate description of the item desired.
- b. The Project Manager shall prepare a stock requisition NDOT Form 146 for such office and field supplies as may be required for a reasonable length of time. Additional stock requisitions may be submitted as field supplies are depleted. The carrying of large quantities of supplies in the field office should be avoided.

17. Stakes

Construction stakes are stored at the Department's supply base in Lincoln. The following types of stakes are available and are listed in the Supply Catalog.

Class	Stock No.	Type	Dimensions	Packaged	General Use
58	85700	"A" Oak	1" x 2" x 18"	50	Reference Stake; Blue Top
58	85705	"A" Oak	1" x 2" x 12"	50	Reference Stake; Blue Top
58	85712	"B" Oak	2" x 2" x 9"	50	Pavement Hub; Location Hub
58	85740	"C" Pine	1" x 2" x 16"	50	Reference Stake; Blue Top
58	85730	"D" Pine	½" x 2" x 16"	100	Lath; reference, guard and ROW stakes
58	85720	"E" Oak	2" x 2" x 20"	25	Reference Hub
58	09700	Lath	½" x 2" x 36"	50	Reference Stake; Lath

18. Local Purchase Of Services

Local services shall be processed for payment by the Project Manager by coding attachments and by indicating their approval signing and dating the bill. Coding attachments are NDOT Form 160 for all services except telephone bills and

NDOT Form 57 for telephone bills. Chapter 4 of the accounting and DOT-OI 80-9 should be reviewed.

19. Equipment Inventory

Equipment listed in the Department's Statewide Inventory System will be inventoried when requested by Operations. The internal control and inventory of equipment not listed will be established by the District/Division.

20. Non-NDOT Equipment Calibration Policy

a. Highway Construction Work

This policy is applicable to all non-NDOT equipment used for the inspection of highway construction work under the jurisdiction of the Nebraska Department of Transportation.

- (i) NDOT will not provide calibration services for consultants, contractors, or other testing firms performing inspection work; however, the calibration must be performed by a commercial laboratory or business.
- (ii) All equipment shall be calibrated at least annually and at any other time when the results of tests are questionable or unreliable. (With the development of Nebraska's Quality Assurance Program for Construction, a set calibration schedule will be implemented for the various types of inspection equipment. This calibration schedule may be other than annual.)
- (iii) A "Certificate of Calibration" shall be available for inspection by NDOT personnel at any time. The "Certificate of Calibration" shall provide, at a minimum, the following information:
 - Serial number or identification number of the equipment.
 - Date of calibration.
 - Results of the calibration.
 - Name of the laboratory or company performing the calibration.
- (iv) NDOT inspection personnel have the right to verify the calibration of any inspection equipment owned by a consultant, contractor, or other testing firm by performing an independent calibration check. The decision to perform an independent calibration check rests solely with NDOT personnel and will not be performed on a request basis.

APPENDICES

BRIDGE DESIGN DIVISION



Mark Traynowicz
Bridge Engineer
Mark.Traynowicz@nebraska.gov
(402) 479-4701

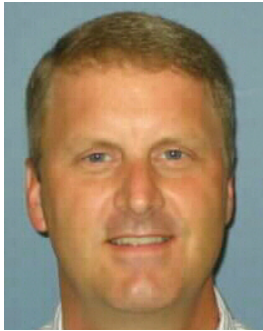

Jeff Handeland
Jeff.Handeland@nebraska.gov
(402) 479-3973

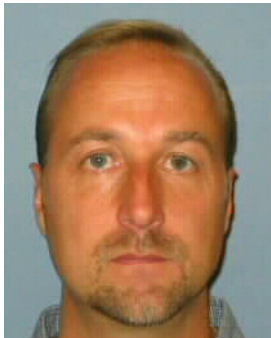

Mark Borgmann
Mark.Borgmann@nebraska.gov
(402) 479-4763

COMMUNICATIONS AND PUBLIC POLICY DIVISION



Vicki Kramer
Hwy Communications Division Manager
Vicki.Kramer@nebraska.gov
(402) 479-4512



Jenifer Campana
Hwy Communication Services Manager
Jeni.Campana@nebraska.gov
(402) 479-4357

CONSTRUCTION DIVISION

Construction Engineer

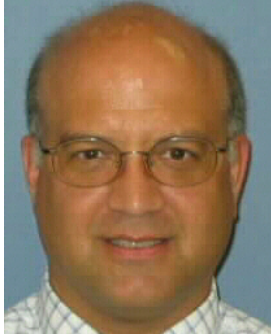

Jim Knott
State Construction Engineer
Jim.Knott@nebraska.gov
(402) 479-4532



Lorraine Legg
Assistant State Construction Engineer
Lorraine.Legg@nebraska.gov
(402) 479-4455



Andy Dearmont
Assistant State Construction Engineer
Andy.Dearmont@nebraska.gov
(402) 479-4451

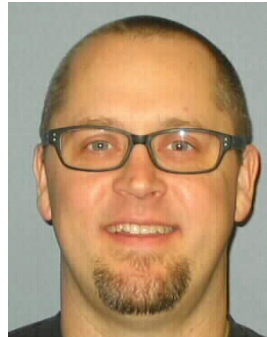

Roy Leach
Finals Supervisor
Roy.Leach@nebraska.gov
(402) 479-4456



Jason Volz
Assistant State Construction Engineer
Jason.Volz@nebraska.gov
(402) 479-4452



Mike Sklenar
Mike.Sklenar@nebraska.gov
(402) 479-4844

DISTRICT ONE



Thomas Goodbarn
District Engineer
Thomas.Goodbarn@nebraska.gov
(402) 471-0850



Curtis Mueting
District Construction Engineer
Curt.Mueting@nebraska.gov
(402) 471-0850



Robert Rankin
Assistant District Construction Engineer
Robert.Rankin@nebraska.gov
(402) 479-0850

DISTRICT TWO



Timothy Weander
District Engineer
Tim.Weander@nebraska.gov
402-935-5410



Marvin Lech
District Construction Engineer
Marvin.lech@nebraska.gov
402-935-5402



Maurice Hinchey
Assistant District Construction Engineer
Maurice.Hinchey@nebraska.gov
402-595-2534

DISTRICT THREE



Kevin Domogalla
District Engineer
Kevin.Domogalla@nebraska.gov
402-370-3470



Pat Boyle
District Construction Engineer
Pat.Boyle@nebraska.gov
402-370-3470



Rob Davis
Assistant District Construction Engineer
Rob.Davis@nebraska.gov
402-370-3474

DISTRICT FOUR



Wesley Wahlgren
District Engineer
Wes.Wahlgren@nebraska.gov
308-385-6265



Keith Meyer
District Construction Engineer
Keith.Meyer@nebraska.gov
308-385-6265



Jason Rotter
Assistant District Construction Engineer
Jason.Rotter@nebraska.gov
308-385-6265

DISTRICT FIVE



Doug Hoebet
District Engineer
Doug.Hoebet@nebraska.gov
308-436-6587



Scott Sorensen
District Construction Engineer
Scott.Sorenson@nebraska.gov
308-436-6587

DISTRICT SIX



Gary Thayer
District Engineer
Gary.Thayer@nebraska.gov
308-535-8031



Cameron Craig
District Construction Engineer
Cameron.Craig@nebraska.gov
308-535-8031

DISTRICT SEVEN



Kurt Vosburg
District Engineer
Kurt.Vosburg@nebraska.gov
308-345-8490



Drew Wilson
District Construction Engineer
Drew.Wilson@nebraska.gov
308-345-8490

DISTRICT EIGHT



Mark Kovar
District Engineer
Mark.Kovar@nebraska.gov
(402) 387-2471



Jason Lehn
District Construction Engineer
Jason.Lehn@nebraska.gov
(402) 387-2471

MATERIALS & RESEARCH DIVISION



Mick Syslo
Materials Engineer
Mick.Syslo@nebraska.gov
Office – 402-479-4750



Mark Lindemann
Geotechnical Engineer
Mark.Lindemann@nebraska.gov
Office- 402-479-4752
Cell - 402-326-4670

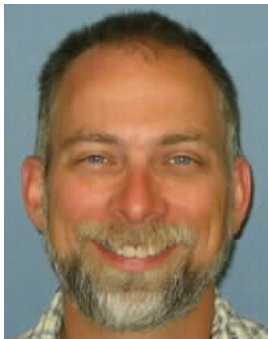

Wally Heyen
Concrete Engineer
Wally.Heyen@nebraska.gov
Office- 402-479-4677

RIGHT OF WAY DIVISION

ROADWAY DESIGN DIVISION



Mike Owen
Roadway Design Engineer
Mike.Owen@nebraska.gov
(402) 479-4601

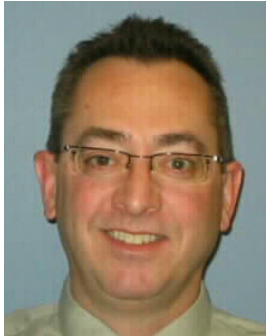

Carl Humphrey
Lighting Engineer
Carl.Humphrey@nebraska.gov
(402) 479-3842

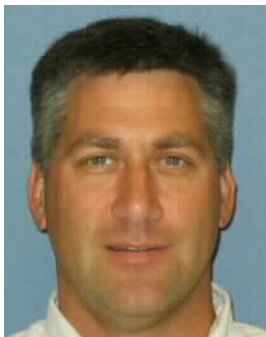

Phil Tenhulzen
Standard Plans Engineer
phil.tenhulzen@nebraska.gov
(402) 479-3951

TRAFFIC ENGINEERING DIVISION



Dan Waddle
Traffic Engineer
Dan.Waddle@nebraska.gov
402-479-4594



Matt Neemann
Matt.Neemann@nebraska.gov
402-479-4594



Kevin Wray
Kevin.Wray@nebraska.gov
402-479-4594

100 Administration



Memorandum

DATE January 18, 2018

TO District Engineers, District Construction Engineers, Assistant District Construction Engineers, Project Managers

FROM James J. Knott, NDOT State Construction Engineer

THRU

SUBJECT DIRECTIVE CONSTR 18-01
ENVIRONMENTAL REVIEW OF CONTRACT CHANGES

This Directive supersedes the interim email guidance, "Environmental Review of Contract Changes", dated January 6, 2017.

CONSTRUCTION DIRECTIVE

This Directive provides policy for the interpretation of paragraph 1. d. of subsection 104.02 of the 2017 Standard Specifications for Highway Construction as it applies to alteration of plans or character of work. This Directive describes the process to accomplish and document environmental review of contract changes.

Paragraph 1.d. of Subsection 104.02 reads as follows:

"The proposed changes will be reviewed to determine if there will be additional environmental impacts that were not addressed in the environmental documents, permits, agency commitments or the contract. This review shall occur prior to work commencing on the proposed changes."

It is the policy of NDOT that the attached "Environmental Review for Change Orders Process", dated November 2017 and hereby incorporated into this Directive, be followed on all projects, except those let through the Aeronautics Division. No alterations to the plans or character of work are to be performed prior to an environmental review of the proposed changes.

Every contract change order must include an environmental review statement. See example statements in the guidance below.

If analysis (as described in Attachment 'A' of the "Environmental Review for Change Orders Process") demonstrates that the change order work is exempt from further environmental review, include the following statement in the body of the change order:

"The proposed change(s) described in this change order has been evaluated in the District for effects to the environment and for compliance with the project contract. The proposed change(s) is exempt from further environmental review."

If, after completing the Change Order Environmental Review Form NDOT194, the proposed change is found to be in compliance with the environmental commitments and permit conditions, include the following statement in the body of the change order:

“The proposed change(s) described in this change order has been reviewed for effects to the environment and for compliance with the project contract. The proposed change(s) complies with the contract environmental commitments.”

If, after completing the Change Order Environmental Review Form NDOT194, the proposed changes require additional environmental commitments, include the following statement in the body of the change order:

“The proposed change(s) described in this change order has been reviewed for effects to the environment and for compliance with the project contract. The proposed change(s) requires that additional commitments be implemented. The additional commitments are: *(insert additional commitments)*.”

If the alteration in the plans or character of work is due to a plan revision, the environmental review will usually be completed in the Central Complex. Since all plan revisions are coordinated through Roadway Design, the design staff will review the revision work with the Roadway Design Environmental Liaison Unit Head to determine whether the proposed changes contemplated in the plan revision will require additional environmental review. The Environmental Section will complete the additional environmental review. The revision transmittal letter to the project manager will include a notification saying that the environmental review has been completed and the work on the revision may proceed with any noted commitments. Please include the appropriate statement in the Change Order as recommended in the revision transmittal letter:

“The proposed change(s) described in this change order has been reviewed during development of the plan revision for effects to the environment and for compliance with the project contract. The proposed change(s) *(insert appropriate statement as noted in revision transmittal letter)*.”

If the alteration in the plans or character of work proposed in the plan revision must take place prior to completion of the revision, it is the responsibility of the District to complete the Change Order Environmental Review process below and include the appropriate statement noted above prior to work commencing.

**Environmental Review for Change Orders Process
November, 2017**

Introduction:

Scope changes during construction and numerous other reasons can necessitate the need for a Change Order. These changes have the potential to impact the natural, human and/or economic environment. When implementing change orders, it is important to verify that the environmental permits and commitments associated with the project continue to be met with the changes in activity. With a Change Order, it is imperative to review the action to determine if there will be additional environmental impacts that weren't addressed in the environmental documents, permits or agency commitments. Change Orders can necessitate the need for changes to permits, concurrences from environmental resource agencies or mitigation. This process will ensure that change orders receive the proper environmental review, when needed, and that District Personnel know when to coordinate with the Environmental Section. Continual training of the District staff on environmental issues is a key component to providing an educated assessment of the environmental issues related to the change order activity.

Review Exemptions:

There are numerous types of Change Orders that will not have environmental impacts. NDOT's Construction Office, with input from the Environmental Section, has established a list of exempted change order types. If the change order activity is consistent with the activities described in the exemptions list included in Attachment A, it shall be documented by the Project Manager as exempt from further environmental review and the Change Order may be processed. At a minimum, the NDOT Project Manager shall document the exempted activity that corresponds with the Change Order request.

***NOTE:** The NDOT Construction Office and Environmental Section will consider modifications to the exemptions list on an annual basis, or as needed. No modifications to the exemptions list will occur without coordination and approval by the Federal Highway Administration (FHWA).*

Environmental Review Process:

Project Level and District Review

The NDOT Construction Project Manager is responsible for initiating the Change Order process. When a Change Order is initiated, it is reviewed against the Contract, Green Sheets and Right of Way commitments to determine the level of environmental review necessary. The Change Order Environmental Review Form NDOT194 (COERF) must be completed and decisions documented in the

Change Order prior to processing the Change Order. The Change Order Environmental Review Form has been designed so that if the questions in the first block can be answered "Yes" by the NDOT Project Manager, processing of the Change Order may proceed without additional review by the District Environmental Coordinator or NDOT's Environmental Section. The COERF will be filed in OnBase (NDOT's document management software).

If the Project Manager determines the answer to a question in Block "A" is "No", or if it is unclear how to answer a question, they will coordinate with the DEC to ensure the proper answer. If any questions are answered "No" in Block "A", the Project Manager will forward the form to the District Environmental Coordinator for further processing. The District Environmental Coordinator will then review the Change Order and complete Block "B" to determine if it can be processed in the District or if additional input or review is needed from NDOT's Environmental Section. If no additional review is necessary, the District Environmental Coordinator will complete Block "B", sign the form and notify the Project Manager that the Change Order can proceed through the remainder of the approval process.

Central Complex and (if necessary) FHWA Review

When the checklist indicates that an Environmental Section review is required, the District Environmental Coordinator will submit the appropriate information to the Roadside Stabilization Unit (RSU). The RSU staff member will coordinate with the appropriate Environmental Section Professional Qualified Staff (PQS). Once the Change Order is reviewed by the appropriate Environmental staff, the RSU staff member will sign the review and notify the Project Manager and District Environmental Coordinator that the Change Order can proceed through the remainder of its approval process. On federal aid projects, the RSU will transmit review material received from the PQS to the NDOT NEPA Specialist responsible for the NEPA document. Assuming that additional Resource Agency consultation is not necessary, NDOT has a goal to complete the review process within five business days. This timeframe is necessary due to review times, staff schedules and the time necessary to coordinate with external parties (when needed).

When the PQS or NDOT NEPA Specialist determines that FHWA review is required to approve the Change Order, an RSU staff member will submit the Change Order and the completed COERF to the FHWA Area Engineer, the Program Delivery Team Lead, the Environmental Protection Specialist and the official FHWA mailbox. This will be the case for Change Orders on federal aid projects where the proposed change order work exceeds a CE PA Level 2 threshold or were reviewed under NEPA as an EA, or EIS. When FHWA environmental approval is required, FHWA has a goal of reviewing the environmental material within two business days.

When Resource Agency (e.g. US Army Corps of Engineers, US Fish and Wildlife, Nebraska Game and Parks, Nebraska Historical Society) consultation is required, the NDOT Environmental Section or FHWA (based on existing agreements) will consult with the required agencies to obtain necessary additional permits, amendments and/or agency concurrences. The NDOT Environmental Section, in consultation with FHWA for federal-aid projects, will review information received from the Resource Agencies and

determine if additional surveys or other activities are warranted. Consultation with Resource Agencies will require additional time to complete the environmental review. RSU will provide an estimate of the review time to the Project Manager. Based on the review time needed, the Project Manager will need to determine if the Change Order will continue to move forward.

When all required coordination has been completed, the RSU staff will sign the COERF and upload the document to OnBase along with any additional documentation provided by the appropriate Resource Agencies and/or by the appropriate NDOT Environmental Section Specialist(s). Examples of this documentation may consist of permit amendments, agency coordination documentation, survey documents, NDOT PQS technical review, as well as any information necessary to document the efforts related to the agency coordination.

RSU will notify the Project Manager and District Environmental Coordinator that the COERF has been uploaded to OnBase and that the Change Order can proceed through the remainder of the approval process. For federal-aid project Change Orders that are reviewed by NDOT's Environmental Section, RSU will send the final COERF and associated documentation to FHWA's official mailbox for their records.

Process Monitoring

NDOT's Environmental Section routinely audits construction projects that are permitted under the Construction Stormwater program. As a component of the records review portion of the audit, a spot check of Change Orders will occur to ensure that the procedures are being properly implemented.

- The NDOT Environmental Section will conduct a "Spot Check" QA/QC review within six (6) months of implementation of the process. The NDOT Environmental Section will review approximately 50% of the Change Orders from each District and provide FHWA a "Spot Check" summary report documenting the number of Change Orders reviewed, trends, and potential corrective actions if needed.
- The NDOT Environmental Section, in coordination with FHWA, will conduct a process audit within one (1) year of the "Spot Check" QA/QC review. The change orders audited are intended to be those received within the construction season, generally March to November. The audit sample size will be determined ensuring it is a statistically valid sample with a 95% confidence level and +/- 10 confidence interval. Projects included in the audit would be sampled across districts, incorporating various project types. This audit shall be completed prior to the following construction season to allow for process modifications and/or corrective actions if needed. A summary report will be provided to FHWA and NDOT District Construction Engineers documenting the number of Change Orders reviewed, trends, and potential corrective actions, if needed.
- Upon completion of the process audit, NDOT shall establish a future audit frequency based on the findings in the report.

Staff Training

Training will continually be provided to the District Environmental Coordinators and construction staff to assist them in making the decisions necessary to evaluate their Change Orders for environmental issues. The training will be conducted in a variety of ways, such as; District Environmental Coordinator meetings, District Environmental Roundtable Meetings, Project Manager's Conference, as well as additional concept specific meetings and classes. In addition, NDOT's Environmental Section publishes an Environmental Newsletter that is distributed to our construction personnel and contractors. This newsletter is another means of educating about environmental issues. The training topics are focused on the checklist items and ensuring that staff can make appropriate decisions.

The following table outlines the training opportunities, audiences required to attend and when they typically occur.

Training Type	When	Attendees
Introduction to NEPA and Transportation Decision Making	One Time – NHI Class	DECs
CEPA Training	One Time	DECs
Wetland Basics	One Time	DECs
Erosion Control Inspector Training	As Needed	DECs, PMs, Construction Staff, Contractors
Environmental Coordinator Meetings	3-4 times per year	DECs, Select PMs, Select DCEs
Environmental Roundtables	Annually, during winter	DECs, DCEs, PMs, Construction Staff
Project Manager Conference	Annually in March	DECs, DEs, DECAs, PMs
Concept Specific Trainings	To Be Determined	To Be Determined
Environmental Newsletter	Published Periodically	DEs, DECAs, DCEs, PMs, Construction Staff, Contractors

NDOT Environmental Section will develop a training course for the NDOT Categorical Exclusion Programmatic Agreement (CEPA) to be required of DECAs and recommended for all NDOT construction staff. The CEPA training course will focus on threshold concepts related to affected resources. Additional required trainings (Concept Specific Trainings) may be designated based on the results of annual (or other designated audit schedule/frequency) process audit results.

Additionally, all District Environmental Coordinators will be provided notice of, and encouraged to participate in NDOT sponsored Environmental Training events. The authority for DEC's to complete Block B of the COERF without project-specific oversight will be contingent upon their completion of the four core classes listed above and a probationary period of one construction season. The four core classes consist of the following:

- Introduction to NEPA and Transportation Decision Making – NHI
- CEPA Training
- Wetland Basics

- Erosion Control Inspector Training

During the probationary period, the RSU will provide a final review of Block B DEC assessments prior to final approval.

The NDOT Environmental Section will document District Construction staff participation as described above with the following information at a minimum: Title, Date, Location, Agenda or Training Syllabus associated with the training, and participation documentation. Training documentation will be provided to FHWA during the appropriate process audit events or upon request by FHWA.

Implementation

The Environmental Review for Change Orders process shall be implemented on January 1, 2018. Change Orders considered for all active NDOT construction projects shall include Environmental Review documentation as described in this process agreement.

Attachment A

Exemption List

NOTE: *The NDOT Construction Office and Environmental Section will consider modifications to the exemptions list on an annual basis, or as needed. No modifications to the exemptions list will occur without coordination and approval by the Federal Highway Administration (FHWA) Assistant Division Administrator or Division Administrator. These items are exempt as long as they do not conflict with commitments contained within the Green Sheet, NEPA documents or permits.*

1. Added items to pay for or deduct for various contingency incentives / disincentives already included in the contract (e.g.; pavement smoothness, quality, etc.).
2. Added contingency items to pay for pile cut-off; soil set-up factors.
3. Added items for various miscellaneous deductions (e.g.; low cylinder strengths, lost or damaged warning signs, etc.).
4. Added items to pay for removal of unsuitable material encountered during excavation. Stipulations: The material cannot contain waste or hazardous materials, cannot contain archaeological or paleontological material, cannot include brick streets not designated for removal in the contract, cannot occur in areas designated as "do not disturb" in the contract plans, and cannot include potentially historic material not designated for removal in the contract (e.g.; foundations of old buildings, abandoned stone or brick culverts, etc.). Furthermore, the unsuitable material excavation must be contained entirely within the limits of construction and must be properly disposed of in an area that has already been environmentally cleared.
5. Addition of new On-the-Job Training provisions to existing contracts.
6. Added items to provide for material substitutions or testing having no environmental impact (e.g.; substituting one asphaltic concrete type for another, substituting one erosion control type for another.).
7. Time Extensions, provided they do not conflict with commitments contained within the Green Sheet, NEPA document, or permits.
8. Added items for material taken into stock.
9. Adding winter work provisions, provided they do not conflict with commitments contained within the Green Sheet, NEPA document, or permits.
10. Administrative changes such as establishing new funding sections, moving pay items from one group to another, or correcting administrative errors.
11. Changes issued during the final review process.
12. Change orders issued to address changes due to a plan revision when the environmental review associated with the plan revision has been completed in the design process.

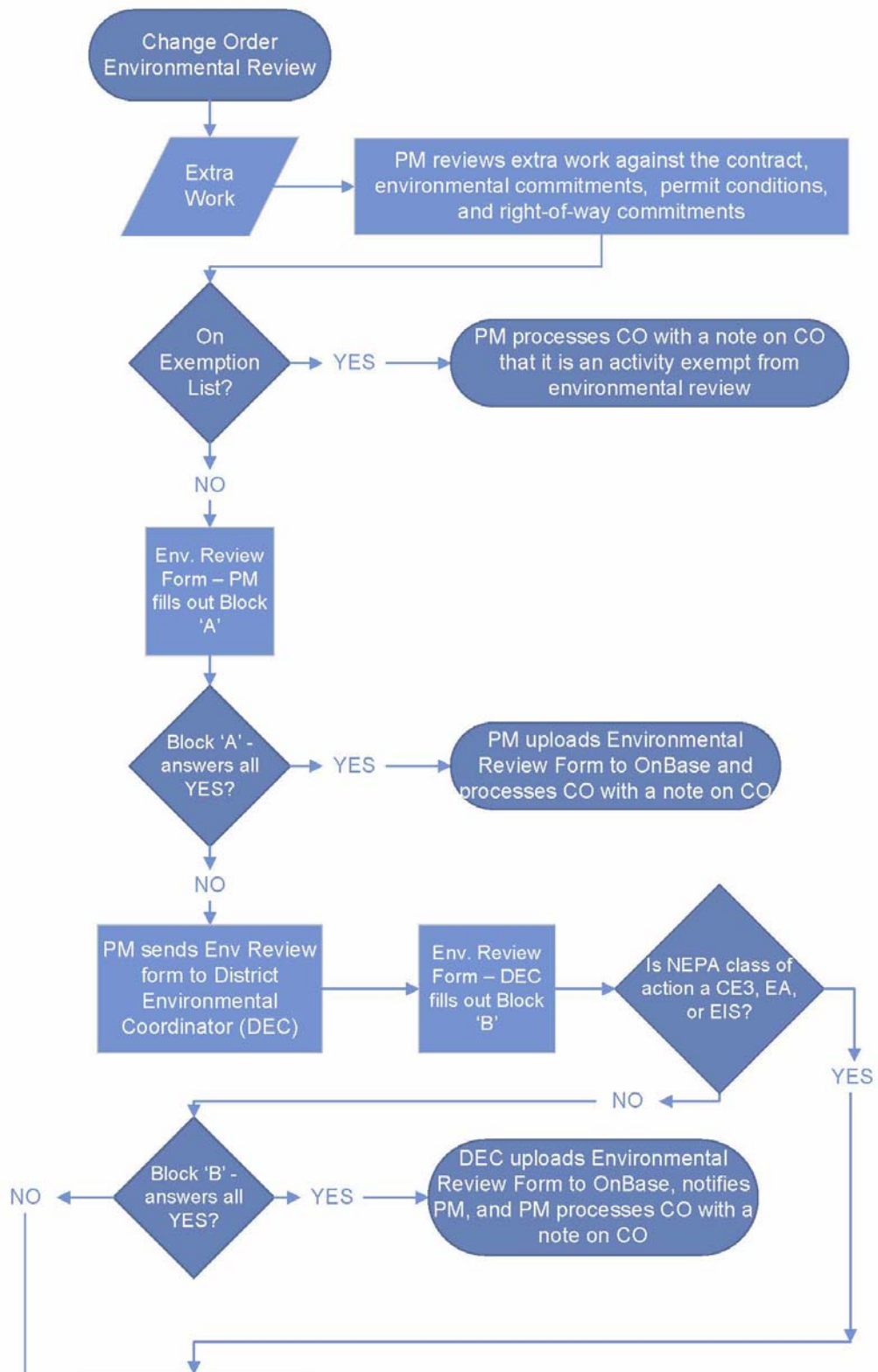

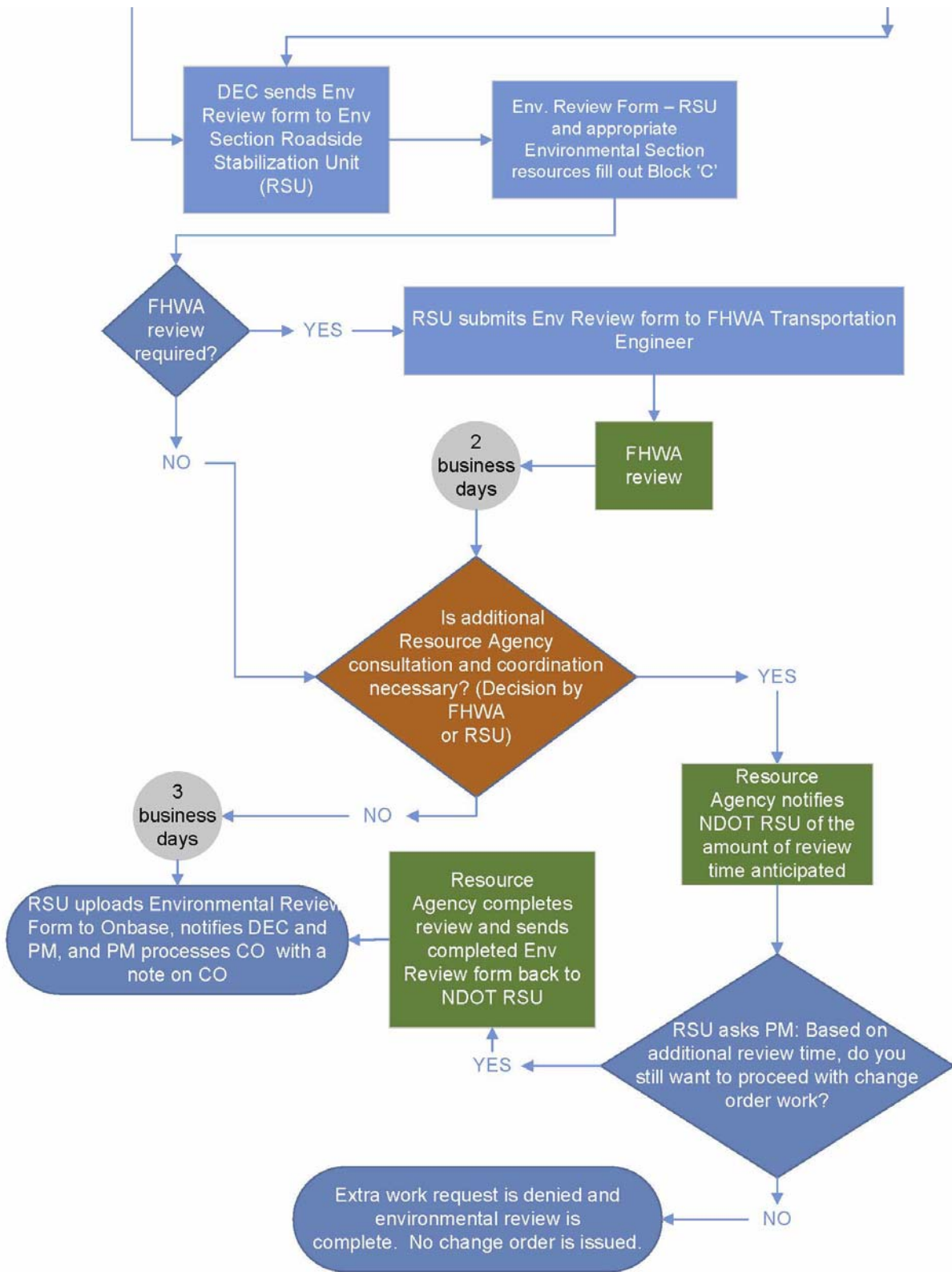

Memorandum

DATE October 9, 2018

TO District Engineers, District Construction Engineers, Assistant District Construction Engineers,
Project Managers

FROM James J. Knott, State Construction Engineer

SUBJECT DIRECTIVE CONSTR 18-04
ENVIRONMENTAL COMMITMENT ASSURANCE

CONSTRUCTION DIRECTIVE

This is a new Directive.

BACKGROUND:

This Directive provides policy to comply with commitments to the Federal Highway Administration regarding compliance with environmental commitments and describes measures to be taken by the District to ensure that construction activities do not impact protected areas described in the contract.

POLICY:

The Project Manager will invite the Environmental Project Managers to attend preconstruction conferences and will include discussion topics about Section 6(f) and/or Section 4(f) resource areas (detailed as "Do Not Disturb" in the construction plans) on the preconstruction conference meeting agenda.

The Project Manager will also include the above discussion topics on the agendas for weekly project meetings, when appropriate.

200 Earthwork



Memorandum

DATE March 30, 2018
TO DE, DCE, PMs
FROM James Knott, NDOT Construction Engineer
SUBJECT DIRECTIVE CONSTR 18-03: CONVERSION OF FIELD MEASURED
 EARTHWORK QUANTITIES TO ESTABLISHED QUANTITY

This Directive supersedes the December 18, 1996 Construction Division Directive.

CONSTRUCTION DIRECTIVE

This Directive is to provide policy for the interpretation of paragraph 1. a. (2) of subsection 109.01 of the Standard Specifications as it applies to earthwork pay items. This policy is created in order to expedite final payment to the contractor, reduce possible interest payments to the contractor, relieve a portion of the workload performed by field personnel, and to expedite contract close out.

Paragraph 1.a.(2) of Subsection 109.01 reads as follows:

"(2) When the work is performed according to the lines, grades, dimensions, and at the locations shown in the contract, the Engineer may elect to pay the plan quantity and not take actual field measurements."

It is the policy of NDOT that the following pay items are eligible to have the method of measurement converted from field measured to established quantity:

1. Excavation Cubic Yard (CY)
2. Excavation Borrow Cubic Yard (CY)

Provided that the following requirements are met:

1. The grading has been built according to plan, or any changes to the plans have been documented by plan revision and/or change order.
2. The contractor has agreed, in writing, to the change in method of measurement.
3. The established quantity has been verified via random "spot checks" of the final grade or other methods as approved by the District Construction Engineer. A record of the verification checks should be stored in Onbase under the NDOT DIST Pay Items document type.

A Change Order Supplemental Agreement will be required to change the method of measurement from field measured to plan quantity. Only the method of measurement should be changed, the original pay item should not be modified.

This is not to be interpreted as an all-or-nothing policy. Areas of earthwork which can't be verified or for which no agreement can be reached may be excluded from the change order and field measured.

400 Traffic Control



Memorandum

DATE March 30, 2018
TO DE, DCE, PMs
FROM James J. Knott, NDOT Construction Engineer
THRU
SUBJECT DIRECTIVE CONSTR 18-02
ACCEPTABILITY OF CONCRETE PROTECTION BARRIERS

CONSTRUCTION DIRECTIVE

This Directive is to provide policy for the type and quality of concrete protection barriers used. This policy applies to both NDOT and Contractor owned barriers used on NDOT projects.

After December 31st, 2019, all new concrete protection barriers built will need to meet the 2016 Manual for Assessing Safety hardware (MASH) criteria. Existing Type "B" and "C" concrete protection barriers that meet NCHRP 350 and were built prior to December 31, 2019 may continue to be used throughout their "normal service life". Type A barriers are not allowed for use on NDOT projects whose contract start date was after January 1, 2018.

NDOT has created two criteria for determining "normal service life":

1. Barriers used on NDOT projects shall be in acceptable condition. The Department has developed the [2018 Nebraska Department of Transportation Evaluation Guide Concrete Protection Barriers March 2018 Edition](#) for determining what acceptable condition is. This guide should be used for all concrete barriers brought onto projects starting April 1st, 2018.
2. Barriers not conforming to MASH 2016 criteria will not be allowed on projects after December 31, 2027.

For Information:

Type A: 4-loop barriers with a large opening at the bottom.
Type B: 6-loop barriers with 4 lifting slots and no slots for tie-down rods.
Type C: 6-loop barriers with 4 lifting slots and 6 slots for tie-down rods.

INDEX

3

3 m (10 foot) Straightedge..... 75

A

A.G.C. Training Program.....	42
Abutment.....	343
Accelerating Admixtures.....	299
Acceptance	97
Acceptance Letter	98
Additional Survey Work Payment.....	475
Adjacent Land	109
Adjust Manhole to Grade.....	428
Adjusting Aggregate Proportions.....	192
Adjusting Asphalt Cement Contents.....	192
Adjustment of Instruments	480
Adjustments	13
Admixture Dispensers	227
Admixtures	232, 296
AEA.....	241
AED Green Book.....	60
Aggregate.....	155, 241
Aggregate Scale.....	248
Aggregates.....	191, 237
Agitators.....	228, 230
Agreed Unit Price	62
Agreement Responsibilities.....	12
Air Compressors	261
Air Entraining Admixture.....	234
Air Entraining Admixtures.....	297
Air Entrainment	233
Air Temperature	198
Air Voids.....	192
Air Voids Test.....	192
Allowable Area Error	85
Alteration.....	78
Alterations of Plans	70
Alternate Crop Damage Procedure	100
An Equal Opportunity Employer	25
Annual EEO Report.....	35
Appealed Decisions	6
Apply Fertilizer	412
Apprentices	45
Approach Sections	321
Approach Slab.....	343
Approval.....	63
Approved Products List.....	432
Approved Rates	68
Arch Culverts.....	371
Armor Coat.....	218
Army Corps 404 Permits	436
As Built.....	173
As-Built Plans.....	103, 105
Asphalt Binder Quantities and Pay Adjustments	209
Asphalt Cement Content	192
Asphalt Concrete Curb	211
Asphalt Materials.....	190

Asphalt Mixture	208
Asphalt Pavement.....	190
Asphalt Plants	194
Asphalt Report Forms	193
Asphaltic Concrete Construction	202
Asphaltic Concrete Island Noses and Medians	211
Asphaltic Concrete Paving Plant Inspection.....	72
Asphaltic Concrete Surface Course	88
Assurance Sampling and Testing.....	73
ASTM C 94	242
ASTM Standard Reinforcing Bars	344
Authorized Alterations	78
Auxiliary Finisher.....	251

B

Backer Rod	261
Backfilling Culverts – Typical Grading.....	374
Backplates.....	164
Backslope Drains	426
Bale.....	402
Bar Designation System.....	343
Bar Grates for Flared-End Sections	388
Barricades.....	50, 169
Barricades/Plastic Drums.....	179
Base Course	88, 155
Base Plate.....	311
Base Plates	311
Basis of Payment	398
Foundation Course.....	145, 146, 148, 151, 154
Batch Plant.....	232
Batch Quantities.....	237
Batch Scales	74
Batch Volume Underruns	247
Batching Cycle	240
Batching Equipment	226
Batching Inspections.....	237
Batching Operations.....	240
Bearing.....	278
Bearing and Penetration.....	282
Bearing Capacity.....	281
Bearing Capacity Procedure	280
Beginning Rehabilitation.....	31
Beginning the Counting of Working Days.....	52
Bell.....	387
Bell Ends.....	162
Belt Placement.....	318
Benchmarks	469
Bent.....	343
Bituminous Pavement	182
Bituminous Pavement Patching	219
Bituminous Sand Base Course	213
Bituminous Surface Course.....	216
Blade Machines.....	213
Blue Book.....	59
Blue Top Stakes.....	459
Blue Tops.....	125
Bolts	349
Bonded PCC Overlay	266

Borrow.....	94
Borrow and Local Pit Materials Furnished by the State or County and Not Involving the Contractor.....	95
Borrow and Waste Site Restoration.....	142
Bottom of Slab.....	336
Box Culvert Footing.....	275
Box Culverts.....	90
Box-Outs.....	246, 247
Break.....	210
Bridge Approach Guard Rails.....	169
Bridge Approach Smoothness.....	75
Bridge Approach Tapers.....	200
Bridge Capability.....	194
Bridge Connections.....	422
Bridge Deck and Approach Slab Smoothness.....	333
Bridge Deck Curing.....	369
Bridge Deck Removal.....	276
Bridge Deck Smoothness.....	76
Bridge End Condition.....	170
Bridge Ends.....	169
Bridge Floors Concrete.....	322
Bridges and Special Culverts.....	105
Bridges-Steel Beam.....	346
Broken Concrete Riprap.....	424
Bulkhead.....	236
Bump Correction.....	76
Bumps.....	76
Burlap.....	255
Burlap Marks.....	254

C

Cabinet.....	164
Cabinet Doors.....	164
Cable Bracing.....	308
Cable Sheath.....	164
Calcium Chloride Treatment.....	151
Calendar Day.....	53
Calibration.....	122
Cancelled Items.....	79
Carbon Streaks.....	371
Care of Equipment.....	482
Cast-In-Place (Retrofit) Barrier Rail.....	392
Cast-in-Place Concrete.....	278
Catch Basins, Manholes, Inlets, and Junction Boxes.....	428
Cement Bulk Handling Equipment.....	226
Cement Car Record.....	239
Cement Factor.....	239
Cement Hauling Inspections.....	239
Cement Notebook.....	239
Cement Received.....	239
Centerline Tie Bars.....	247
Certificate of Compliance.....	431
Certification.....	260
Certification of Materials.....	190
Certified Plant Inspector Program.....	193
Chain of Command.....	2
Chain-Link Fence.....	426
Change Order Approval Limits.....	63

Change Order Supplemental Agreement.....	140
Change Orders.....	22
Change Order-Supplemental Agreements.....	64
Changeable Message Sign.....	179
Character of Work.....	70
Character of Workpersons.....	56
Checking Bench Levels.....	453
Checking Culvert Lengths.....	459
Checking Plan Grade and Calculating Grade Revisions.....	455
Checking Transverse Joints For Smoothness.....	198
Checklist Safety Program.....	51
Chemical Finishing.....	252
Chip Seal.....	218
Class I Floor Repair.....	369
Cleaned Finish.....	393
Cleaning Joints.....	260
Clearance Letter.....	106
Clearance of Bottom Reinforcement.....	336
Clearance of Slab Reinforcement.....	336
Clearing and Grubbing.....	128
Cloud Cover.....	198
Coarse Aggregate.....	155
Cold Milling.....	214
Cold Milling Equipment.....	215
Cold Seasons.....	267
Cold Weather.....	197, 267
Cold Weather Asphalt Construction.....	197
Cold Weather Pavement Protection.....	267
Cold Weather Paving.....	267
Cold Weather Placement.....	332
Cold Weather Plant Operation.....	267
Collars.....	91
Collars with Bend.....	91
Collecting of Accident Data.....	77
Coloring Agents.....	297
Commercially Useful Function.....	46
Communication Division.....	10
Compacted Layer.....	150
Compaction.....	136
Compaction Requirements.....	234
Composite Girders.....	327
Composition of Concrete.....	232, 296
Concrete.....	280
Reinforcement.....	335
Concrete - Precast Piles.....	321
Structural Units.....	321
Concrete - Prestressed Piles.....	321
Superstructures.....	321
Concrete Barrier Rails.....	321
Concrete Base Course.....	269
Concrete Box Culverts.....	371
Concrete Bridge Deck Repair and Overlay.....	366
Concrete Bridge Deck Repair with Silica Fume Concrete.....	366
Concrete Bridge Floors.....	322
Concrete Construction.....	91
Structures.....	295
Concrete Curb and Concrete Gutter.....	270
Concrete Discharge Times.....	234

Concrete Driveways	268, 271	Contraction Joints	257
Subgrade.....	271	Contractor Furnished Borrow Areas	135
Concrete Elbows, Collars	91	Contractor Markup	62
Concrete Headwalls	91	Contractor's Forms on Large Structures	458
Concrete Island Nose.....	271	Contractor's Responsibilities	475
Concrete Median Barriers	271	Contractor-Owned Equipment.....	59
Concrete Mixers	226	Contractor's Requirements.....	14
Concrete Pavement	88, 231	Contractor's Responsibility.....	34, 36
Material Requirements	232	Contractor's Sales Tax Exemption	49
Preparation of Subgrade	234	Contractor's Standard Forms	193
Concrete Pavement Checklists	221	Contractor's Work Schedule.....	58
Concrete Pavement Failures.....	256	Control Joints	258
Concrete Pavement Repair	269	Controlled-Access	49
Removal of Old Pavement	270	Controller.....	164
Concrete Pavement Repair Checklist.....	225	Conventional Light Poles.....	175
Concrete Piling.....	277	Correcting Earthwork Areas	85
Concrete Pipe Culverts	92, 386	Corrugated Metal Pipe	92
Concrete Placement.....	313	Corrugated Metal Pipe Arches	92
Concrete Plant Checklist.....	223	Corrugated Metal Pipes.....	385
Concrete Sampling Locations	233	Cost Overrun/Underrun Notification (NDOT Form 74)	
Concrete Seal Course	89, 275	66
Concrete Sewer Pipe	388	Cover Crop Seeding.....	405
Concrete Shoulders	253	Covercrop Seeding Checklist	404
Concrete Spreader.....	228	CR MS-3	195
Concrete Strength	233	Crack Sealing in Bituminous Surfacing	220
Concrete Surface Finish (Rail and Beams)	392	Cracking.....	361
Concrete Ticket.....	242	Cracks.....	258
Concrete Washout	418	Crane and Bucket	317
Concreting in Cold Weather	320	Crash Notification Procedure	172
Conductors.....	159	Critical Construction Areas.....	281
Conduit.....	164	Crop Damage.....	99
Conduit Ends.....	162	Cross Drains	
Conduits.....	159	Longitudinal.....	426
Confined Elastomeric Bearing Devices	370	Cross Section Accuracy.....	471
Conflict of Interest	7	Cross Section Notes	472
Consolidation of Concrete.....	319	Cross Sections	144
Construction Critical Area.....	222, 226	Crown.....	229, 247, 251
Construction Critical Areas.....	224	Crown Check.....	229
Construction Division	2	Crown Checks	248
Construction Division (EEO Section).....	38	Crushed Rock	155
Construction Engineer.....	2	CSS-1	209
Construction Inspection.....	51	CSS-1H.....	209
Construction Joints for Box Culverts	375	Culvert.....	371
Construction Methods	397	Culvert Excavation	90, 273
Construction of Bridge Approach Fills	138	Culvert Footings.....	372
Construction of Embankment Toe Berms	138	Culvert List	376, 385
Construction Period.....	47	Culvert List – Box Culverts	460
Construction Requirements.....	159	Culvert Lists	459
Construction Staking	29, 444	Culvert Pipe.....	93, 376, 386
Construction Staking as Contract Item.....	475	Culvert Sandfill	389
Construction Technician (CT).....	5	Culverts.....	92, 105
Construction Work Zone Signing During Winter		Curb	246, 263
Shutdown	168	Curing	254, 331
Construction Zone Accident Reporting.....	171	Curing Concrete	333
Consultant Survey Data	441	Curing of Keyed and Doweled Joints	263
Consultant Surveyors	441	Current Controlling Operation	53
Contingencies	93	Curvature	85
Contract Administration.....	1, 395, 476	Curve	408
Contract Documents	22	Cutback Asphalt.....	198
Contract Time Determination	51	Cyclone Seeder.....	395
Contract Time Extensions	77		
Contract Unit Price	62		

D

Daily Cement Record	239
Daily Plant Operation	193
Daily Plant Report	192, 193
Daily Record	70
Daily Report of Concrete Pavement Laid (NDOT Form 85)	268
Damaged Edges	255
Damaged Equipment	481
Dampproofing	429
Data Collector	84
DBE	45, 47
DBE Owner	47
Deck Joint Seals	389
Deck Overlay Preparation	369
Deck Shims	325
Deduction	154
Deduction for Signs	170
Defects	342
Deficiency	150
Delayed Estimates	98
Delegation of Authority	1
Delegation of Responsibility	5
Delineators	146
Densities	144
Density - Void Conflicts	204
Density Controls	202
Density Samples	203
Department Responsibilities	476
Deposition of Embankment Material	136
DEQ	435
Design Mix	237
Determining Cause	196
Detour	77
Detour Report	20
Detour Signs	50
Dewater	275
Diamond Grinding	265
Diesel Hammers	282
Diggers Hotline	24, 30
Diluted Emulsion	210
Diluted Emulsions	210
Diluted Material	210
Dilution of Emulsion	209
Director	1
Disadvantaged Business Enterprise (DBE)	45
Discharge Cycle	240
Discharge Structures	425
Disposal of Asphaltic Concrete Pavement	133
Distribution of Materials	153
District Construction Engineer (DCE)	3
District Estimates	13
District Maintenance Engineer	173
Divided Highway Condition	169
Do Not Pass (R4-1)	170
Documentation	476
Dowel Assembly Placement	262
Dowel Bars	244, 256
Dowel Baskets	244
Dowel Midpoint Markings	262
Dowel Tolerances	261

Doweled Support Assemblies	261
Drag Finish	252
Drill Settings	394
Driveway Grades	235
Driveways	235
Dry Film Paint Thickness	365
Drying and Recompaction	196
Dump Trailers	195
Dust Control	417
Dynamic Pile Analyzer	283

E

E.E.O. Meetings	25
E.E.O. Officer	25
E.E.O. Policy	25
E.E.O. Posters	25
Earth and Rock Checks	415
Earth Shoulder Construction	146
Earth Shouldering	77
Earthwork Calculations	474
Earthwork Engineering Guide	144
Earthwork Measurement Conversion	100
Earthwork-Measured-in-Embankment	139
Edge Alignment	197, 200
Edge of the Traveled Way	147
EEO Policy Statement	25
EEO Requirements	24, 34
EEO Violations	36
Electrical Power	162
Electronic Digital Theodolite/Transit (Maintenance)	479
Electronic Digital Theodolite/Transit (Precautions)	479
Embankment Construction	136
Emergency Notification	436
Employee Policies	13
Emulsion	210
End Anchorage	423
End Gate Cyclone Seeder	395
End Treatments	423
Engineering Equipment, Supplies and Services	476
Engineering, Surveying and Testing Equipment	477
Ensure Proper Shim	326
Environmental	435
Environmental Conditions	328
EPA	435
Epoxy Coated Bar	338
Epoxy Coated Bars	340
Epoxy Coating	341
Epoxy Coating Thickness	342
Epoxy-Coated Reinforcement	338
Equal Employment Opportunity	30
Equal Employment Opportunity (EEO)	34
Equipment	59, 124, 154, 169
Rented	60
Equipment Inventory	483
Equipment Operators	59, 60
Equipment Purchased	96
Equipment Rental	60, 429
Equipment Rental Rates	68
Equipment to be Used	29
Erosion Checks Checklist	402

Erosion Control	125, 402, 413
Erosion Control Checklist	401
Erosion Control Plan	394
Errors	8
Estimates	81
Evaluation	334
Evaluation of Contractor	108
Evaporation Retarders	252
Example Calculation.....	410
Excavating and Backfilling.....	385
Excavation.....	93, 134
Box Culverts	273
Bridges	273
Catch Basins	273
Headwalls.....	273
Inlets	273
Junction Boxes	273
Miscellaneous Structures	273
Pipe Culverts.....	273
Retaining Walls	273
Sewers	273
Steps.....	273
Excavation and Backfilling.....	387
Excavation and Embankment.....	134
Excavation Borrow	135
Excavation for Bridges	89
Excavation for Culverts	90
Excavation for Structures	89, 273
Material Requirements	273
Excavation Operations	437
Excessive Edge Slump.....	264, 265
Exempted	16
Exemptions from Subcontract Requirements	16
Existing Stop Signs	167
Expansion Joints	247, 252
Extra Work	67, 144, 145

F

Failures	144
Fair Labor Standards Act	41
False Statements	7
Falsework.....	305, 314
Falsework Design.....	307
Falsework Foundations	306
Falsework Inspection.....	305
Falsework Piles	306
Fast-Ball.....	409
Fasteners	355
Fertilizer	395
Fertilizers	
Example Calculations.....	407
Fertilizing.....	407
FHWA	11
FHWA/Certification Acceptance	63
Fiber Optic Cable	30
Field Adjustments.....	166
Field Approval of Subcontract Work.....	15
Field Computations	84
Field Cultivator	395
Field Documentation	302
Field Driving Problem	292

Field Inspection	340
Field Laboratories	419
Field Personnel Duties & Staff Requirements	13
Field Records	79
Field Site Manager Entries	80
Field Testing Laboratory.....	232
Field Tests	73, 80, 190
Field Voids	192
Field Welding	337
Filler-Bitumen Ratio.....	193
Final	110
Final Cleaning Up.....	109
Final Computations	97
Final Cross Section Guidance.....	472
Final Cross Sections	472
Final Estimate	96
Final Inspection and Acceptance	97
Final Payment	84, 96, 97
Final Quantities	95, 472
Final Records	99
Final Review Process Manual	97
Final Signal Turn On	165
Finaling Procedures	109
Fine Aggregate.....	155
Fine Grading	143
Finely Divided and Permeability	297
Finely Divided Mineral Admixtures	300
Finish grading.....	119
Finish Sod	412
Finished Pavement	200
Finishing.....	139
Finishing Equipment.....	228, 236
Finishing Machine	229, 248, 331
Finishing Machines	201
Fixed Bearings and Expansion Bearings, TFE Type	370
Fixed Form Jersey & Retrofit Rail	391
Flaggers	179
Flared-End Sections.....	388
Flexible Pavement Engineer	192
Floated Surface Finishes.....	393
Floor Drains.....	333
Flowable Fill	320
Flume Reinforcement.....	374
Flumes	425
Fly Ash	157
Fly Ash (Class C & F).....	300
Fog Seal.....	216
Force Account	62
Force Account Agreements	68
Force Account Agreements and Statements.....	68
Force Account Statements	70
Form Alignment Ahead of Paver	244
Form and Falsework Removal	372
Form FHWA 1273	43
Form FHWA-1391	36
Form FHWA-47	83, 103
Form Identification and Use	193
Form Setting.....	244
Form Settlement.....	247
Form WH-348.....	83
Forms.....	33, 230, 244, 315

Forms WH-348.....	81
Foundation	275
Foundation Course.....	87, 148, 235
Foundations	275
Free Liquids	437
Freight Rates.....	50
Frost Boil.....	196
Frozen Material	135
Full Depth PCC Patches	269, 270
Fully Operated.....	59
Fully Operated Rates	69
Furnish Rock or Gravel	154
Furnishing and Planting of Plant Materials	418
Checklist.....	396

G

Gabions and Revet Mattresses	424
Galvanized Bolts	355
Galvanized Metal Pipes.....	385
General Comments	396, 400, 401, 402
General Information	172
General Inspection	394
General Project Supervision.....	9
General Requirements	273
General Structure Backfilling.....	274
General. Horizontal and Vertical Control.....	441
GeoPak Guidance.....	450
Grade and Alignment Stakes	441
Grade Stakes	31, 143
Gradeline Strings	197
Grades on Drives in Cities.....	235
Grading	105
Grading Inspection	124
Granular Fill.....	148
Granular Subdrains	427
Gravel	155
Gravel Surfacing	87
Gravity Seeder	395
Grinding	334
Grooving	253
Ground Rod.....	164
Grout.....	393
Guardrail	94, 146, 170
Guardrail Installations	419, 422
Guardrail Posts	421
Guideline Strings.....	197
Guidelines	59
Guidelines for Tining	253
Gutter	246

H

H Pile	281
Hair Checks.....	254
Handrail.....	371
Hardware.....	371
Haul Roads	32
Haul Time.....	243
Hauling	74, 150
Hauling Equipment.....	227
Hauling Materials	153

Hauling On or Over Surfaced Roads.....	125
Hazardous Material	133
Head of the Pile.....	280
Head to Head	77
Header	256
Header Boards	256
Head-to-Head Projects.....	170
Health.....	50
Health Standards	50
Heavy Disc.....	395
Heavy Hexhead Structural Bolts	348
High Mast Lowering Systems.....	177
High Mast Towers	175
High Production Pavement Projects.....	250
High Range Water Reducing Admixtures (Type F).....	298
High Strength Bolts	312
High Strength Fasteners	349
Highway Right of Way	49
Hiring.....	25
Holes in Poles	164
Holiday Detector.....	342
Hoppers	74
Horizontal Reinforcement.....	337
Hot Box Samples	202
Hot Pour Joint Sealer	259
Hot Pour Kettles.....	261
Hot Poured Asphaltic Joint Material	261
Hot Poured Sealants	258
Hourly Operating Costs	59
Hourly Rental Rate	59
Hub Line.....	249
Hydromulching	411
Hydro-Seeder.....	395

I

Idled Equipment	61
Impact Attenuator	170
Impervious Coatings	254
Incentive/Disincentive Payment	188
Incidental Construction.....	419
Inertial Barrier Modules	423
Inertial Barrier Systems.....	179
Inlet	246
Inlet and Utility Accesses	246
Inlet Protection	417
Inlet Standards	246
Inlets	
Abandoning	428
Inspecting Rehabilitation Work.....	32
Inspection	
Equipment.....	152
Inspection Considerations	411
Inspection Crew 182, 221, 223, 225, 399, 400, 401, 402, 403, 404	
Inspection Equipment.... 159, 182, 221, 223, 225, 396, 400, 401, 402, 403, 404	
Inspection Notebooks.....	79
Inspection of Driving Equipment.....	287
Inspection of Driving Equipment During Installation	289
Inspection of Piles Prior to and During Installation	285

Inspection Procedures	182
Inspector's Records & Forms	186
Inspector's Records and Forms	282
Installation	385, 387
Installation of Right-Of-Way Markers	469
Installing Tie Bars	425
Insulation	267
Integral Curb	258, 263
Integral Curb Placement.....	263
Integrity	7
Interest	96
Interest Payments	98
Interlocked Automatic Batching Controls.....	240
Interpretation of Specifications	3
Intersections.....	472
Interstate Traffic Control Requirements	170
Introduction	99
Investigation Procedure.....	172

J

Jacking Culvert Pipe, Sewer Pipe, and Casing	389
Job Control Testing	193
Joint Filling	261
Joint Sealer	259
Joints.....	199, 255, 374
Junction Box in Bridge Curb.....	160
Junction Boxes	
Abandoning	428

L

Labor Classification	41
Labor Laws Cited	40
Labor Market	26
Land Survey Monuments	462
LANE RENTAL.....	111
Lane Shifts	181
Lap Requirements.....	344
Lapping of Guardrail.....	422
Laydown	
Foundation Course.....	150
Laydown Procedures.....	183
Laying Out Joints	258
Laying Widths for Asphalt.....	200
Lead-Based Paint Removal.....	390
Leaky Mixer Valves	241
Leased Equipment	60
Letter of Transmittal	109
Light Pole	174
Lighting	159
Lighting and Signals.....	106
Lighting Checklist.....	159
Lighting Control Center	160, 176
Lighting Engineer	172
Limestone.....	155
Limitations	266
Line and Grade	249
Liquidated Damages	76, 96
Load Ticket	74
Local Pit	94
Local Purchase Of Services	483

Location of Markers.....	469
Longitudinal Cracks.....	392
Longitudinal Drains	427
Longitudinal Joint Design	263
Longitudinal Joints	199, 258
Loop Wire.....	165
Loops, Preformed.....	163
Loops, Sawed	163
Lost Transverse Groove.....	265
Lowering System.....	177
Luminaires.....	176

M

Machine Finishing	250
Magnetic Detectors	163
Magnetic Dry film	365
Magnetic Dry Film	365
Magnetic Locator.....	245
Mailbox Post.....	429
Mailbox Turnouts	
Special Surface Course.....	426
Mailboxes	146
Main Screed.....	250
Maintained Traffic.....	123
Maintenance Contracts	36
Major Item	62
Manholes	
Abandoning	428
Marking Joint Locations.....	262
Mass of Asphalt Cement	189
Mass Per Unit Volume	189
Mast Arms	163, 164
Master Straightedge.....	230
Mastic Sealants.....	260
Mat Smoothness Machine.....	195
Material Details	430
Material Inspections	236
Material Placement	193
Material Quantities	268
Material Requirements	397
Material Storage.....	169
Material Transfer Vehicle	194
Materials	73
Salvaged	96
Measurement	77
Measuring Asphalt Binder for Small Quantities	209
Mechanical Strike-off.....	228
Mechanically Stabilized Earth Walls - Modular Block	
.....	370
Mechanically Stabilized Earth Walls with Concrete	
Facing Panels	370
Media Guide.....	10
Median Construction	151
Median Crossings	170
Metal Chairs	244
Metering	123
Method of Measurement	147, 148, 151, 154
Method of Measurement	121, 145, 146
Method of Measurement and Basis of Payment.....	95
Method of Measurement Procedures	281
Metric System of Measurement.....	78

Microsurfacing.....	217
Microtest	342
Milling Machine	214
Milling Machines.....	266
Mineral Filler.....	155
Minimum Allowable Asphalt Cement.....	192
Minimum Penetration	282
Minimum Survey Requirements	445
Miscellaneous Equipment	230
Miscellaneous Material Requirements.....	234
Mix	191
Mix Change.....	191, 193
Mix Design Letter	193
Mixer Performance Tests	227
Mixers	228
Mixing.....	241
Mixing and Hauling.....	240
Mixing Drum.....	228
Mixing Paint.....	363
Mobilization	60, 95
Moisture	144
Moisture Content.....	150
Moisture Curves	138
Motor Carrier Permit Office	74
MTV	195
Mud	372
Mud Ball Repair.....	266
Mudsills.....	306
Mulch Crimper.....	395
Mulch Perimeter Control.....	415
Mulching.....	409

N

Native Grass Seed Drill.....	395
NDOT Form 84.....	44
NDOT Form 85.....	247
NDOT Form 91.....	96, 97
NDOT T 168.....	203
NDOT Tests	185, 223, 224, 226, 281
NDR Approved Products List	432
Nebraska One Call Notification System	24
News Media Relationships	10
No Passing Zones on Construction Projects	167
Nomograph	234
Non-cohesive Sand.....	146, 156, 157
Non-NDOT Equipment Calibration Policy.....	483
No-Passing.....	167
No-Passing Zone	167
Notice to Proceed.....	52
Notification of Project Completion	96
Nuclear Density Gauge	202
Number of Hours.....	60

O

Obtaining Materials From Local Pits	145
Occupational Safety and Health	34
Old Substructures	276
On Standby	69
One Call Notification	30
Open Dumping	437

Optional Borrow	95
Ordering Material	385, 386
Ordinary Surface Finish.....	393
Ornamental Handrail	371
OSHA.....	34, 435
Other Excavation Areas	472
Other Reference.....	403
Other References... 396, 399, 400, 401, 402, 403, 404	
Outlets.....	427
Out-of-Tolerance Tie-Bar Steel	246
Outside Agencies Relationships.....	11
Overhaul	86, 142
Overhead and Profit.....	60
Overruns and Underruns Letter.....	106
Overtime	42
Overweight Axle Loads	124

P

Pad Mounted Controllers.....	164
Paint Film	363
Paint Thickness.....	365
Painting	362, 363
Painting Structural Steel.....	363
Paired Signs.....	166
Pan Float.....	251
Pan-Type Finisher-Float.....	229, 250
Partnering.....	11
Partnering Opportunities	30
Patching Procedures.....	225
Paved Shoulders.....	202
Pavement	
Damaged.....	255
Pavement Construction	231
Pavement Depression	254
Pavement Edge.....	144
Pavement Station Stamping.....	263
Paver.....	247
Pavers	250
Paving Equipment	226
Paving Form Stakes.....	458
Paving Hubs.....	143, 459
Paving Train.....	250
Pay Item Documentation	121
Payment.....	77
Payments	81
Payrolls	40, 43
Peat Moss Checklist.....	404
Ped Head	165
Ped Pushbuttons.....	165
Pedestrian Heads.....	165
Penetration of.....	280
Performance Graded Binder Content.....	209
Permanent Benchmarks Along Rural Highways.....	470
Permanent Seeding	404
Permanent Station Numbers	263
Perpetuation of Section Corner Markers	466
PG Binder/RAP – Pay Adjustments	209
Photographs.....	79
Pier.....	343
Pile Driving.....	277
Pile Driving Analyzer	279, 280, 282

Pile Driving Constraints	283	Postings	22, 51
Pile Driving Procedures	278	Practical Refusal	281
Pile Groups/Categories	283	Precast Concrete	
Piles		Piles	321
Precast Concrete	321	Structural Units	321
Preparation for Driving	283	Superstructures	321
Prestressed Concrete	321	Precast Concrete Piles	285
Piles and Pile Driving	91, 277	Precast/Prestressed Concrete	
Pilot Cars	179	Construction Methods	321
Pipe	386	Material Requirements	321
Pipe Arch Culverts	92	Precast-Prestressed Concrete	
Pipe Arches	91, 385	Description	321
Pipe Bedding	377	Precautions and Maintenance of Survey Equipment	
Pipe Computations	94	478
Pipe Culverts	91	Preconcreting Conference	231
Pipe Marking	385, 386	Preconstruction Conference	20, 115, 123, 171
Pipe Ordered But Not Used	93	Preconstruction Cross Sections	470
Pit Materials	94	Preformed Loops	171
Pit Site	152	Preformed Polychloroprene Elastomeric Type	259
Place Sod	412	Preliminary Cross Sections Used to Compute Final	
Placement and Checking (Bridge Deck)	336	Quantities	471
Placement Considerations	329	Preliminary Staking	162
Placement Procedures	221	Preliminary Survey Requirements	470
Placement Rates for Hot Mix Asphalt Bases, Binder,		Preparation of Existing Box Culverts	89
and Surface Courses	201	Preparation of Existing Structures	89
Placement Tolerances	245	Preparation of Subgrade	234
Placing	247	Prepour Meeting	323
Placing and Fastening	337	Presence on Site	8
Placing Concrete	316, 372	Preserving, Perpetuating	464
Placing Reinforcing Steel	244	Prestressed Concrete Bearing Pile	281
Plan Revisions	63	Preventing Damage to Utility Properties	31
Plan Stationing	147	Prewatering Plan	139
Planimeter Method	84	Price Adjustment	96
Plans and Working Drawings	8	Prime Coat and Tack Coat	87
Plant Calibration	302	Problems and Solutions	326
Plant Inspection	72	Procedures & Comments	403, 404
Plant Inspector	73	Procedures and General Comments	403
Plant Monitor	72, 194	Processing As-Built Plans	106
Plant Procedures	224	Profilograph	76, 187, 230
Plant Reports	73	Profilograph Procedures	230
Plant Ticket	233	Profilograph Tests	76
Plants	23	Progress	79
Plastic Concrete	264	Progress Estimates	81
Plastic Drums	170	Progress of Work	57
Platform Scale	75	Progress Schedule	53
Plotting Cross Sections	475	Project Acceptance	96
Pole Bases	163	Project Acceptance Sampling and Testing	73
Pole Foundation	174	Project Details	27
Pole Foundations	162	Project Finalization	96
Poles	163	Project Manager	12, 15
Poles and Towers	175	Project Manager (PM)	4
Policy for Change Orders	62	Project Manager Involvement	15, 34
Policy for Placement of Template Correction on		Project Manager's Involvement	38
Overlay Projects	201	Project Station Reference Stakes	153
Polyethylene Sheeting	255	Project Supervision	23
Poor Fusion	361	Project Suspensions	58
Porous Backfill	427	Proper Girder Seat Elevations	326
Portland Cement Concrete (PCC) Pavement	221	Proper vs. Improper Shims	326
Portland Cement Concrete Pavement	226	Protection	254
Portland Cement Concrete Pavement Smoothness		Protection of Foundation Course	235
.....	230	Protection of Material	336
Portland Cement Concrete Paving Plant	72	Protection of Pavement	236

Public Relations	9
Public Relationships	9
Pull Boxes	159
Pump Placement	318
Pushbutton Signs	165
Pushbuttons	165

Q

QA/QC	190
QA/QC Program	190
QA/QC Specification	73
QC Lab Technician	194
QC Program	193
Quality Assurance Section	231
Quality Assurance/Quality Control	193
Quality Control Methods	205
Quality Control Monitoring	205

R

Radius Computation	86
Rail Alignment	421
Rail Height	422
Rail Section Location	421
Railroad Protective Insurance	27
Railroad Right-of-Way	30
Rain Damage	255, 264
Raised Pavement Markers	181
Random Cracks	270
Random Sampling	202
Rate of Fertilizer	395
RDP Form 344, Evaluation of Contractor	108
Ready Mix Concrete	233
Ready Mix Tickets	72
Ready-Mixed Concrete	243
Reconciliation of Records	61
Reconstruction of Manholes	428
Record of Contractor Payrolls Received	44
Records	26
Records and Reports	268
Recruitment	25
Reference Points	280
Reimbursable Trainee Training Record	39
Reinforced Concrete Pavement	257
Reinforcement	91, 335
Description	335
Material Requirements	335
Protection of Material	336
Reinforcement Bar Cover	319
Relations with Cities and Counties	10
Removal and Disposal of Old Pavement	132
Removal and Processing of Concrete Pavement	154
Removal of Existing Structures	89
Removal of Falsework	314
Removal of Forms and Falsework	316
Removal of Structures and Obstructions	131
Removal of Wall Forms	374
Removing and Resetting Trees	396
Removing and Resetting Trees Checklist	396
Removing Materials from Projects	8

Rental Rate Blue Book	59, 69
Rented	60
Repair of Damaged Coating	340
Repair of Deficient Pavement	264
Report of Labor Compliance Interviews	42
Report of Shipment of Reinforced Concrete	386
Reporting Violations	153
Reports	33, 38
Reproducing and Referencing Centerline	454
Request for Authorization of Additional Classification and Rate	42
Required Posting	35
Requisition And Transfer	477
Residents Along Construction Projects	9
Residue Rates	210
Resurfaced PCC	269
Resurfacing	200
Retarders - Retarders	330
Rice Voidless Density	202
Riding Qualities	250
Right of Way	24, 99
Right-of-Way and Barbed Wire Fence	425
Right-of-Way Limit Listing	455
Right-of-Way Markers	426
Riprap Filter Fabric	389
Road Gravel Requirements English Version	155
Roadway Excavation	84
Roadway Grading	141
Rock	155
Rock Material	135
Rock or Gravel Surfacing	152
Rock Riprap	424
Roller Marks	198
Rome Disc	395
Rotational-Capacity	351
Rough Pavement Sections	266
Rough Sawn Timbers	307
Rough Welding	360
Rounding of Hinge Points	125
ROW Line	441
Royalty Payments	95
Rubbed Finish	393
Rubber Grommets	164
Rumble Strips	204
Ruts	321

S

Safe Work Site	51
Safety	24, 30, 50, 162
Safety Areas	185, 223, 224, 226
Safety Inspections	51
Salvage	377
Salvage Value	377
Salvaged Culvert Pipe	377
Salvaging and Placing Topsoil	141
Salvaging Bituminous Material	215
Sample for Compliance	210
Sample Identification Form	193
Samples	72, 202
Sampling	152

Sampling Requirement/Freq.	185	Shoulder.....	188, 321
Sand.....	155	Measured.....	147
Sand Gravel.....	155	Shoulder Maintenance.....	321
Sandblast.....	260	Shoulder Subgrade Preparation.....	143
Sand-Gravel.....	155	Shrinkage Cracks.....	265
Saturdays.....	54	Sign Color.....	166
Saw Cut Loop Location.....	162	Sign Mounting Devices.....	179
Saw Cuts.....	270	Sign Shape.....	166
Sawed Joint.....	259	Sign Size.....	166
Sawing Equipment.....	229	Sign Word Message.....	166
Saws.....	229	Signal Ahead Signs.....	165
Scale Bins.....	237	Signal Head.....	165
Scale Calibration Record.....	239	Signal Heads.....	165
Scale Houses.....	419	Signing Changes.....	166
Scale Tickets.....	74, 80	Signing Service.....	19
Scale Weights.....	238	Signs.....	50, 146, 159
Scales.....	74, 75, 226, 237	Silicone Sealants.....	260
Scarifying.....	196	Silt Checks.....	415
Schedule of Delivery.....	243	Silt Clay Soils.....	146
Scotchkote 213.....	342	Silt Fence.....	416
Scotchkote 312.....	342	Silt Fencing Checklist.....	402
Screed.....	251	Silt Fencing Procedures.....	402
Screeds.....	229	Silt Trap.....	416
Seal Bridge Deck Cracks.....	332	Silt-Clay.....	146
Sealing Equipment.....	261	Simultaneous Casting of Deck and Approach Slabs.....	333
Sealing Joints.....	212, 258	Single Acting Diesel Hammers.....	290
Sealing Sawed Joints.....	261	Site Inspections.....	35
Sealing Transverse and Longitudinal Cracks.....	271	Site Mixers.....	243
Section.....	147	Site Preparation.....	136
Section Corners.....	268	SiteManager Item Documentation.....	80
Seed.....	405	Skew Angles.....	275
Seed Bed.....	405	Skewed Dowels.....	256
Seed Mixtures.....	395	Skidmore-Wilhelm Calibrator.....	353
Seeding Checklist.....	399	Skidmore-Wilhem Calibrator.....	345
Seeding Procedures.....	399	Slab.....	343
Segregated Facilities.....	24	Slab Report.....	247
Self-Propelled Concrete Spreader.....	250	Slab Thickness.....	248, 336
Self-Propelled Finishing Machine.....	250	Slider.....	408
Self-Propelled Finishing Machines.....	330	Slip Form Barrier Rail.....	392
Services Relationships.....	10	Slip Form Paving Equipment.....	229
Set Accelerating Admixtures.....	297	Slip-Form.....	248
Set Retarding Admixtures.....	296	Slip-Form Construction.....	248
Setting Beams.....	321	Slip-Forming.....	247
Setting Finishing Stakes.....	457	Slope Protection.....	411
Setting Slope Stakes.....	456	Slope Protection Checklist.....	403
Setting Trimming.....	458	Slope Protection Netting Checklist.....	403
Setting Witness Corners.....	466	Slope Stakes.....	459
Settlement.....	144	Slope Tracking.....	416
Settlement of the Falsework.....	313	Slow/Slow Paddles.....	180
Sewers.....	93, 388	Smoothness.....	75, 198, 333
Shallow Penetration.....	361	Smoothness of Bridge Decks.....	334
Shape Sod Bed.....	412	Snow Removal.....	168
Shear Connectors.....	355	Snug Tight.....	352
Sheet Pile Turndown.....	372	Sodding.....	412
Sheet Piles.....	278	Sodding Checklist.....	400
Sheet Piling.....	91	Sodding Procedures.....	400
Shells.....	278	Soft Subgrades.....	196
Shipping.....	481	Soil Aggregate Base Course.....	
Shop Coat.....	364	Tolerance.....	151
Shop Drawings.....	171	Soil Amendment.....	409
Shore Head.....	311	Soil Binder.....	146, 155
Shoring Components.....	311		

Soil Load Test	307	Steel Roller.....	200
Soil Roughening	416	Steel Sheet Piles	287
Soil Setup Factor.....	279	Steel Structures.....	345
Soil Type	144	General Requirements	346
Solid Waste	436	Material Requirements	346
Spade Lugs	164	Stockpile	236
Spalls	259	Stockpile Item.....	82
Span Wire	164	Stockpiled.....	169
Special Attention Areas	337	Stockpiled Material	22, 82
Special Attention Items	476	Stockpiles.....	49
Special Concerns	168	Stockpiling.....	82
Special Equipment	194	Stockpiling Material	215
Special Treatments	197	Stop Bars	181
Specialized Work Items.....	57	Stop Sign Removal	165
Specification Provisions	56	Stop Signs.....	167
Spike Tooth Harrow	395	Storage Areas	169
Splice Kit	164	Storage Locations	169
Splices	164	Straightedge.....	198
Splicing	343	Straightedging	251, 331
Splicing Pile.....	283	Stranded Wire	164
Split-Ball.....	409	String.....	200
Spray Bar	210	String Support Arms.....	197
Spread Footings.....	306	Strip Seals.....	389
Spreader	228, 251	Stripping, Salvaging, and Spreading	141
Spreading.....	247	Struck Loads	154
Spreading Layers	201	Structural Concrete	303
Spring Tooth Harrow	395	Structural Concrete Plant	72
Spud Wrench	352	Structural Joints	347
SS-1	209	Structural Steel.....	307
SS-1H	209	Structures	
SSHC Reference.....	399, 400, 401, 402, 403	Concrete Construction.....	295
SSHC References..	182, 221, 223, 225, 396, 403, 404	Description	273
SSHC Subsection 703.03.....	278	Equipment.....	273
Stabilized Construction Exit.....	418	Excavation.....	273
Stabilized Subgrade Type Fly Ash	157	General Procedures	273
Stabilized Subgrade Type Lime	156	Structures - Concrete Construction	
Staff Requirements	13	Material Requirements	296
Stakes	483	Subcontract.....	19
Stakes Used.....	275	Subcontract Request And Approval	13
Staking	153, 275, 441	Subcontracted Items	62
Staking Culverts and Structures.....	462	Subcontracting	23
Staking Right-of-Way Fence	455	Subcontracts	13
Standard Labor Classifications.....	42	Subdrain Earthwork.....	426
Standby Time	61	Subdrains.....	426
Stand-by Time.....	243	Subgrade.....	196, 247
State Option	94	Damage.....	145
State Supplied Material	162	Subgrade Cross Sections.....	235
Statement of Compliance	43, 83	Subgrade General.....	234
Statement of Materials and Labor	83	Subgrade Preparation	143
Form FHWA-47	103	Subgrade Stabilization	145
Static Pile Load Test Procedures	280	Subgrade Trimmer	228
Station Numbers	264	Subgrade Trimming.....	144
Stationary Mixers	243	Subsurface Drainage Matting.....	389
Steel "H".....	280	Sundays	54
Steel diaphragms	390	Supplies	482
Steel H-Piles	286	Support Rails.....	331
Steel Overhang Brackets	308	Supports.....	337
Steel Pile Cutoffs.....	283	Surface Checking (Not in Spec)	333
Steel Piling	277	Surface Cleaning.....	236
Steel Pipe Piles.....	287	Surface Correction	334
Steel Railings	371	Surface Finish	392
Steel Reinforcing Bars	244	Surface Finishing	250

Surface Holes.....	360
Surface Irregularities.....	198
Surface Water.....	439
Surfacing.....	106
Surfacing Gravel.....	155
Survey Accuracy.....	441
Survey Errors.....	276
Survey Levels (General Precautions).....	480
Survey Levels (Maintenance).....	480
Suspension of Work.....	56

T

Tack Coat.....	209
Tamp.....	412
Tank Measurement.....	209
Taper Lengths.....	166
Taper Location.....	167
Tapping Existing Drainage and Sewer Facilities.....	388
Temperature of Concrete.....	301
Template.....	145
Temporary Barrier.....	170
Temporary Culvert Pipe.....	377
Temporary Fastenings.....	335
Temporary Filler.....	256
Temporary Lighting Systems.....	177
Temporary Lighting Units.....	177
Temporary Pavement Markings.....	180
Temporary Seeding.....	406
Temporary Signal.....	162
Temporary Slope Drain.....	417
Temporary Stop Sign.....	167
Temporary Surfacing.....	154
Temporary Traffic Signals.....	168
Temporary Water Pollution Control.....	133
Tension Measuring.....	353
Tentative Acceptance.....	140
Tentative start Date.....	51
Test Strips.....	197
Testing Equipment.....	72
Testing of Aggregate.....	152
Testing Procedures.....	233
Thickness Cores.....	230
Thickness Measurements.....	235
Thickness Requirements.....	267
Threads.....	353
Thrie-Beam Guardrail.....	421
Ticket.....	234
Tickets.....	74, 88
Tie Steel.....	245
Tie-Bar Steel.....	245
Tie-Bar Steel Inspection.....	245
Tile Relocations.....	426
Timber.....	307
Timber Construction.....	309
Timber Piling.....	314
Time	
Active.....	61
Standby.....	61
Time Suspensions.....	57
Tine Determination.....	253
Tining.....	252, 331

Top Layer.....	189
Top Steel.....	330
Topsoil on Roadway Cuts and Embankments.....	141
Total Hourly Rate.....	59
Total Stations (Maintenance).....	478
Touch-Up Material.....	342
Tower Foundations.....	174
Toxic and Hazardous Wastes.....	437
Traffic Control.....	159, 188
Traffic Control Removal.....	170
Traffic Control Signing.....	166
Traffic Control Signing Changes.....	165, 166
Traffic Engineering.....	162
Traffic Signal Heads.....	164
Traffic Signals.....	159
Trainee Recruitment.....	38
Trainee Reimbursement.....	37
Training.....	26, 36
Training Program.....	35, 36, 38
Transit Mixers.....	230, 244
Transition Mat.....	415
Transitions.....	251
Transit-Mixed Concrete.....	243
Transporting Equipment.....	481
Transverse Construction Joints.....	256
Transverse Contraction Joints.....	257
Transverse Expansion Joints.....	256
Transverse Finishers.....	251
Transverse Grooving.....	266
Trench Excavation.....	427
Trimming.....	150
Trouble Shooting.....	359
Truck.....	152
Truck Agitator.....	247
Truck Capacity Computations.....	87
Truck Mixer.....	247
Truck Mixers.....	241, 242, 243
Truck Platform Scale.....	75
Truck Platform Scale Use.....	75
Truck Weights.....	74
Trucks and Mixers.....	227
Truck's Gross Mass.....	152
Tubular Markers.....	170
Tubular Steel Shoring.....	308
Turbidity Barrier.....	417
Turn-of-Nut Inspection.....	353
Turn-of-Nut Method.....	351
Two Way Traffic" (W6-3).....	170
Two-Lane, Two-Way Condition.....	169
Type II Barricades.....	170
Type III Barricades.....	169
Typical Channel Section.....	90

U

U.S. Survey Monuments.....	462
Unauthorized Work.....	109
Uncompleted Projects.....	168
Uncontrolled Crack.....	258
Undercut.....	360
Underground Tanks.....	437
Union Pacific Railroad.....	31

Unmarked Human Burial Sites	125
Unstable Areas	196
Unstable Subgrades	195
Unsuitable Material	135, 196
Unsuitable Material Excavation	273
Urban Projects	168
Urban Work	145
Use of Insulated Forms for Protection	316
Used Construction Equipment	59
UTILDONE	32
Utilities	27, 31
Utilities Engineer	32
Utility	171
Utility Accesses	246
Utility Companies	31
Utility Properties	31
Utility Work	171

V

Value Engineering	71
Vehicle Traffic on Plastic Concrete	265
Vertical Panels	170
Vibrators	228
Video Tape	147
Video Tapes	79
Voids	266

W

Wage Rate Interviews	39
Wage Rates	22, 39, 41
Wages	39
Wash Water in Transit-Mix Trucks	241
Wasted Water	122
Water	147, 234, 242, 252, 412

Water Pollution & Wetlands	24
Water Supply Equipment	230
Water Valve	241
Water, Applied	122
Ways to Avoid Deck Cracks	332
W-Beam	421
Weekdays	54
Weekly Report of Working Days	23, 58
Weld Spatter	360
Wet Batch Trucks	230
Wet Burlap	254
White Pigmented Curing Compound	254
Width of Preliminary and Preconstruction Cross Sections	474
Wind Velocity	198
Wind Velocity Temperature	329
Wind Velocity-Temperature	368
Windrow Pick-up Elevator	195
Windrow Pick-up Equipment	195
Winter Shutdown	168
Winter Work	58
Wiring	164
Witnessing Land Survey Monuments	464
Work Area Speed Zone	167
Work Authorized to Begin Date	52
Work on Adjacent Lanes	369
Work Order	67
Work Orders	67
Work Status	15
Work Temporarily Suspended	56
Work Zone Signing	170
Working Day	53, 77
Working Day Report and Diary Record	55
Workload	13
Wrench Calibration	353